



Coco Vista Centre
 466 SW Port St. Lucie Blvd, Suite 111
 Port St. Lucie, Florida 34953
 772-462-1593 www.stlucietpo.org

TECHNICAL ADVISORY COMMITTEE (TAC)

Regular Meeting

Tuesday, May 21, 2024
 1:30 pm

Public Participation/Accessibility

Participation in Person: Public comments may be provided in person at the meeting. Persons who require special accommodations under the Americans with Disabilities Act (ADA) or persons who require translation services (free of charge) should contact the St. Lucie TPO at 772-462-1593 at least five days prior to the meeting. Persons who are hearing or speech impaired may use the Florida Relay System by dialing 711.

Participation by Webconference (not intended for Committee Members): Using a computer or smartphone, register at <https://attendee.gotowebinar.com/register/4824854273727041880>. After the registration is completed, a confirmation will be emailed containing instructions for joining the webconference. Public comments may be provided through the webconference chatbox during the meeting.

Written and Telephone Comments: Comment by email to TPOAdmin@stlucieco.org; by regular mail to the St. Lucie TPO, 466 SW Port St. Lucie Boulevard, Suite 111, Port St. Lucie, Florida 34953; or call 772-462-1593 until 1:00 pm on May 21, 2024.

AGENDA

1. Call to Order
2. Roll Call
3. Comments from the Public
4. Approval of Agenda
5. Approval of Meeting Summary
 - *March 19, 2024 Regular Meeting*
6. Action Items
 - 6a. Draft FY 2024/25 – FY 2028/29 Transportation Improvement Program (TIP): Review of the draft FY 2024/25 – FY 2028/29 TIP.

Action: Recommend adoption of the draft TIP, recommend adoption with conditions, or do not recommend adoption.

- 6b. 2024/25 List of Priority Projects (LOPP): Review of the draft LOPP for 2024/25 for the St. Lucie TPO.

Action: Recommend adoption of the draft 2024/25 LOPP, recommend adoption with conditions, or do not recommend adoption.

- 6c. City of Fort Pierce Passenger Rail Station/Mobility Hub Concepts Plan: A presentation of the planning and concepts for the City of Fort Pierce Passenger Rail Station/Mobility Hub.

Action: Recommend acceptance of the Concepts Plan, recommend acceptance with conditions, or do not recommend acceptance.

- 6d. Transit Development Plan (TDP) Major Update: Review of the draft TDP Major Update for the St. Lucie TPO area.

Action: Recommend endorsement of the draft TDP Major Update, recommend endorsement with conditions, or do not recommend endorsement.

- 6e. Advanced Air Mobility (AAM) Study Phase 2: A presentation of Phase 2 of the AAM Study.

Action: Recommend acceptance of Phase 2 of the AAM Study, recommend acceptance with conditions, or do not recommend acceptance.

7. Recommendations/Comments by Members

8. Staff Comments

9. Next Meeting: The next St. Lucie TPO TAC meeting is a regular meeting scheduled for 1:30 pm on Tuesday, July 23, 2024.

10. Adjourn

NOTICES

The St. Lucie TPO satisfies the requirements of various nondiscrimination laws and regulations including Title VI of the Civil Rights Act of 1964. Public participation is welcome without regard to race, color, national origin, age, sex, religion, disability, income, or family status. Persons wishing to express their concerns about nondiscrimination should contact Marceia Lathou, the Title VI/ADA Coordinator of the St. Lucie TPO, at 772-462-1593 or via email at lathoum@stlucieco.org.

Items not included on the agenda may also be heard in consideration of the best interests of the **public's health, safety, welfare, and as necessary to protect every person's right of access**. If any person decides to appeal any decision made by the St. Lucie TPO Advisory Committees with respect to any matter considered at a meeting, that person shall need a record of the proceedings, and for such a purpose, that person may need to ensure that a verbatim record of the proceedings is made which includes the testimony and evidence upon which the appeal is to be based.

Kreyol Ayisyen: Si ou ta renmen resevwa enfòmasyon sa a nan lang Kreyòl Ayisyen, tanpri rele nimewo 772-462-1593.

Español: Si usted desea recibir esta información en español, por favor llame al 772-462-1593.



Coco Vista Centre
466 SW Port St. Lucie Blvd. Suite 111
Port St. Lucie, Florida 34953
772-462-1593 www.stlucietpo.org

TECHNICAL ADVISORY COMMITTEE (TAC)

REGULAR MEETING

DATE: Tuesday, March 19, 2024

TIME: 1:30 pm

MEETING SUMMARY

1. Call to Order

The meeting was called to order at 1:30 pm.

2. Roll Call

Self-introductions were made, and a quorum was confirmed with the following members present:

Members Present

Adolfo Covelli, Chair
Patrick Dayan, Vice Chair
Jack Andrews
Benjamin Balcer
Noël Comeaux
Robert Driscoll

Andres Elizondo
Cameron Howard

Colt Schwerdt

Others Present

Peter Buchwald
Yi Ding
Marceia Lathou
Stephanie Torres
Rachel Harrison

Representing

St. Lucie County Transit
St. Lucie County Public Works
Fort Pierce Engineering
St. Lucie County Planning
Port St. Lucie Planning
Independent Public Transportation
Operator
St. Lucie County Fire District
Treasure Coast International
Airport
Port St. Lucie Public Works

Representing

St. Lucie TPO
St. Lucie TPO
St. Lucie TPO
St. Lucie TPO
Recording Specialist

Antonio Balestrieri	City of Port St. Lucie
James Brown	Florida's Turnpike
Kelly Budhu	Florida Department of Transportation (FDOT)
Victoria Williams (via web)	Florida's Turnpike

At Mr. Buchwald's invitation, Mr. Schwerdt introduced Mr. Comeaux and Mr. Balestrieri.

3. Comments from the Public – None.

4. Approval of Agenda

* MOTION by Mr. Driscoll to approve the agenda.

** SECONDED by Mr. Schwerdt Carried UNANIMOUSLY

5. Approval of Meeting Summary
 • January 23, 2024 Regular Meeting

* MOTION by Mr. Schwerdt to approve the Meeting Summary.

** SECONDED by Mr. Driscoll Carried UNANIMOUSLY

6. Action Items

6a. Transportation Alternatives Program (TAP) 2024 Grant Application: Review of a TAP grant application for the 2024 cycle.

Mr. Buchwald summarized the types of projects for which TAP funding may be used and explained how and when the \$650,000 of funding available to the St. Lucie TPO for the 2024 grant cycle would be programmed. He indicated that an application had been submitted by St. Lucie County for the Sunrise Boulevard Sidewalk Project, provided details on the project's parameters and cost, and noted that the applicant had requested approximately \$1 million in funding.

Vice Chairman Dayan commended Mr. Buchwald's presentation. He enumerated several benefits of the sidewalk project, reported on the plans for development in the vicinity, and requested the members' consideration of the project on behalf of the County. In answer to

Mr. Andrews' question, Vice Chairman Dayan clarified that the sidewalk would be constructed on the eastern side of Sunrise Boulevard.

* MOTION by Mr. Driscoll to recommend endorsement of the application.

* * SECONDED by Mr. Andrews Carried UNANIMOUSLY

6b. FY 2024/25 – FY 2025/26 Unified Planning Work Program (UPWP): Review of the draft FY 2024/25 – FY 2025/26 UPWP for the St. Lucie TPO.

Mr. Buchwald explained the UPWP as a two-year program of transportation planning activities undertaken by the TPO and supported by State and Federal funds. He described the scope and purpose of the UPWP, noting that the next one would take effect in July 2024, and recounted several accomplishments from the current work program. Mr. Buchwald detailed the public involvement efforts conducted as part of the UPWP development process and identified several recurring projects and efforts that would continue into the new cycle. Mr. Ding, Ms. Torres, and Ms. Lathou then presented, in turn, the proposed projects they would individually be managing.

In response to Mr. Comeaux's question regarding micromobility, Ms. Lathou reported on St. Lucie County's ART On Demand microtransit program. She summarized the discussion the Citizens Advisory Committee members had on the subject earlier that day and detailed the other services provided by St. Lucie County Transit. Mr. Buchwald then elaborated on the planned Electric Bicycle Study, explaining that it would explore ways to address potential safety issues arising from the increased popularity of e-bikes relative to other forms of micromobility, such as scooters and e-scooters. Mr. Schwerdt noted that local homebuilders had recently been giving away e-bikes to their buyers. Mr. Balestrieri expressed his enthusiasm for the Study, citing his previous experience with various e-bike initiatives and requesting to be kept updated on the Study's progress.

Vice Chairman Dayan asked how the geographical parameters of the U.S. Highway 1 Corridor Congestion Study had been chosen. Mr. Buchwald explained that they had been selected based on anecdotal information from various TPO Board members indicating the presence of congestion from the northern boundary of Martin County to Crosstown Parkway. Vice Chairman Dayan suggested that the parameters be extended northward to Prima Vista Boulevard, a recommendation echoed by Mr. Schwerdt and Chairman Covelli.

- * MOTION by Mr. Driscoll to recommend adoption of the draft UPWP with the condition that the parameters of the U.S. Highway 1 Corridor Congestion Study be extended northward to include the intersection with Prima Vista Boulevard.
- ** SECONDED by Mr. Schwerdt Carried UNANIMOUSLY

7. Discussion Items

- 7a. Community Profiles Update: An analysis of Census data for the TPO area that informs and guides the TPO's public outreach to disadvantaged communities.

Mr. Buchwald introduced the agenda item and invited Mr. Ding to continue. Mr. Ding noted the Federal Title VI requirement for MPOs to ensure that traditionally underserved communities were provided with opportunities to meaningfully engage in the transportation planning process, explaining that the development of Community Profiles assisted the TPO in providing those opportunities. He described the methodology by which the update had been completed, a process that included using Census data to identify geographical areas in St. Lucie County with a comparatively high percentage of minority residents, residents with limited English proficiency, residents living below the poverty line, residents living with disabilities, households without a vehicle, and senior residents. Mr. Ding then presented with the aid of a map the geographical areas that had been identified as disadvantaged according to these parameters.

Mr. Comeaux identified the *United Way ALICE Report* (Asset Limited, Income Constrained, Employed) as another source providing demographic data on families on the lower end of the income spectrum but living above the poverty line. Mr. Buchwald thanked Mr. Comeaux for bringing the report to his attention and requested that he send him additional details.

Vice Chairman Dayan referenced the concentration of senior adults living in the County's Southwest Annexation area and noted the importance of that information for future planning efforts. Mr. Schwerdt expressed surprise that the concentration was not higher given recent trends in St. Lucie County.

8. Recommendations/Comments by Members – Vice Chairman Dayan provided details on an upcoming Town Hall meeting to discuss the

potential implementation of railway quiet zones throughout the County, noting that no action was to be taken at the meeting. He explained that Indian River County had recently considered the same issue and subsequently declined to take action, while Martin County had deferred the discussion for one year. In answer to Chairman Covelli’s question, Vice Chairman Dayan indicated that there were 14 rail crossings maintained by the County as well as several others maintained by other jurisdictions.

- 9. Staff Comments – Mr. Buchwald announced an upcoming meeting with Florida East Coast Railway to discuss rail safety in the TPO area. He indicated that he would forward the meeting information to all the members and thanked them for their input.
- 10. Next Meeting: The next St. Lucie TPO TAC meeting is a regular meeting scheduled for 1:30 pm on Tuesday, May 21, 2024.
- 11. Adjourn – The meeting was adjourned at 2:20 pm.

Respectfully submitted:

Approved by:

 Rachel Harrison
 Recording Specialist

 Adolfo Covelli
 Chairman



AGENDA ITEM SUMMARY

Board/Committee:	Technical Advisory Committee (TAC)
Meeting Date:	May 21, 2024
Item Number:	6a
Item Title:	Draft FY 2024/25 – FY 2028/29 Transportation Improvement Program (TIP)
Item Origination:	Unified Planning Work Program (UPWP) and Federal and State requirements
UPWP Reference:	Task 3.3 – TIP
Requested Action:	Recommend adoption of the draft TIP, recommend adoption with conditions, or do not recommend adoption.
Staff Recommendation:	As the draft FY 2024/25 – FY 2028/29 TIP appears to be consistent with the SmartMoves 2045 Long Range Transportation Plan and the Draft Tentative Work Program that was recommended for endorsement by the TPO Advisory Committees, it is recommended that the draft TIP be recommended for adoption by the TPO Board.

Attachments

- Staff Report
- Draft FY 2024/25 – FY 2028/29 TIP



Coco Vista Centre
 466 SW Port St. Lucie Blvd, Suite 111
 Port St. Lucie, Florida 34953
 772-462-1593 www.stlucietpo.org

MEMORANDUM

TO: Technical Advisory Committee (TAC)

THROUGH: Peter Buchwald
 Executive Director

FROM: Yi Ding
 Transportation Systems Manager

DATE: May 14, 2024

SUBJECT: Draft FY 2024/25 – FY 2028/29 Transportation Improvement Program (TIP)

BACKGROUND

According to Federal and/or State requirements, the St. Lucie Transportation Planning Organization (TPO) annually must develop a Transportation Improvement Program (TIP). The purpose of the TIP is to identify the transportation improvement projects located within the TPO area that have been prioritized and are receiving Federal and State funding over the next five years.

In addition, the TIP is used to coordinate projects among the U.S. Department of Transportation (USDOT), the Florida Department of Transportation (FDOT), and the local governments located within the TPO area. The TIP is developed by the TPO in cooperation with these agencies and the Treasure Coast International Airport, the Port of Fort Pierce, St. Lucie Area Regional Transit (ART), and the general public.

ANALYSIS

The development of the TIP is a year-long process that is continuous, cooperative, and comprehensive. For the TPO's FY 2024/25 – FY 2028/29 TIP, the process started in May 2023 with the development of the TPO's List of Priority Projects (LOPP). The LOPP then was reviewed by the TPO Advisory

Committees, adopted by the TPO Board, and submitted to FDOT District 4 in June 2023.

The LOPP was utilized by FDOT District 4 to develop their Draft Tentative Work Program for FY 2024/25 – FY 2028/29. The Draft Tentative Work Program was reviewed and recommended for endorsement by the TPO Advisory Committees and was subsequently endorsed by the TPO Board in October 2023.

The Final Tentative Work Program was received from FDOT in April 2024 and used to prepare the attached TIP that is also available through the web-based Interactive TIP on Community Remarks. The Final Tentative Work Program, which is a primary component of the draft TIP, was reviewed by TPO staff and appears to be consistent with the Draft Tentative Work Program that was recommended for endorsement by the TPO Advisory Committees.

The draft TIP includes the following multimodal highlights:

- The widening of the Midway Road from Glades Cut Off Road to Jenkins Road and the new Turnpike interchange at Midway Road are programmed for construction in FY 2026/27;
- The payback of the local funding by the TPO for the advancement of the widening of Midway Road from Jenkins Road to Selvitz Road is programmed for FY 2025/26;
- The Project Development and Environment Study (PD&E) for the widening of California Boulevard from Del Rio Boulevard to Crosstown Parkway is programmed;
- The PD&E for the widening of I-95 from the Martin County Line to Okeechobee Road is programmed for FY 2024/25.
- The intersection improvement of Gatlin Boulevard at Savona Boulevard is programmed for construction in FY 2024/25;
- The resurfacing of the Green River Parkway Trail from Walton Road to the Martin County Line is programmed for construction in FY 2025/26;
- The construction phase of A1A SUN Trail from Ft. Pierce Inlet State Park to Indian River County Line is programmed in FY 2027/28;

- The design of the Port of Fort Pierce SUN Trail Connector project is programmed for FY 2024/25;
- The sidewalk on Nebraska Avenue from Lawnwood Circle to 13th Street is programmed for construction in FY 2025/26;
- Completing the sidewalk gap on St. James Drive from Lazy River Parkway to Royce Avenue is programmed for construction in FY 2026/27;
- The resurfacing projects of Orange Avenue from Lamont Road to N. 32nd Street and Okeechobee Road from BMP 6.351 to Ideal Holding Road are programmed for construction in FY 2027/28;
- Over \$1,674,000 of funding is programmed for Peacock Trail Project through the TPO's Transportation Alternatives Program (TAP) funding from the 2023 grant cycle;
- The Lakewood Park Regional Bus Service is programmed to start in FY 2024/25;
- The advancement by one year to FY 2026/27 of the right of way phase for the widening of Kings Highway from St. Lucie Boulevard to Indrio Road;
- The advancement by two years to FY 2025/26 of the construction for the widening of Port St. Lucie Boulevard from Becker Road to Paar Drive with local funding and the payback by the TPO of the local funding in FY 2027/28; and,
- The programming of eleven airport projects resulting in approximately \$8 million of new funding.

It should be further noted that the total amount of funding in the draft TIP for the TPO area exceeds a total of \$535 million which exceeds the previous TIP by almost \$90 million. In addition, the draft TIP appears to be consistent with the SmartMoves 2045 Long Range Transportation Plan.

RECOMMENDATION

As the draft FY 2024/25 – FY 2028/29 TIP appears to be consistent with the SmartMoves 2045 Long Range Transportation Plan and the Draft Tentative

Work Program that was recommended for endorsement by the TPO Advisory Committees, it is recommended that the draft TIP be recommended for adoption by the TPO Board.



TRANSPORTATION IMPROVEMENT PROGRAM FY 2024/25 - FY 2028/29

DRAFT

TIP CONTACT INFORMATION

466 SW Port St. Lucie Boulevard
Port St. Lucie, FL 34953

Yi Ding, Program Manager
www.stlucietpo.org

phone: (772) 462-1593
fax: (772) 462-2549

ENDORSEMENT: The Transportation Improvement Program of the St. Lucie Transportation Planning Organization has been developed consistent with Federal regulations 23 U.S.C. 134(j) and 23 CFR 450 and Florida Statute 339.175(8) in cooperation with the Florida Department of Transportation and public transit operators.

ACKNOWLEDGMENT: The preparation of this report has been funded in part through grants from the Federal Highway Administration and Federal Transit Administration, U.S. Department of Transportation (USDOT), under the Metropolitan Planning Program of the U.S. Code (Title 23, Section 104f). The contents of this report do not necessarily reflect the official views or policy of the USDOT.

TITLE VI STATEMENT: The St. Lucie TPO satisfies the requirements of various nondiscrimination laws and regulations including Title VI of the Civil Rights Act of 1964. Public participation is welcome without regard to race, color, national origin, age, sex, religion, disability, income, or family status. Persons wishing to express their concerns about nondiscrimination should contact Marceia Lathou, the Title VI/ADA Coordinator of the St. Lucie TPO, at 772-462-1593 or via email at lathoum@stlucieco.org.

KREYOL AYISYEN: Si ou ta renmen resevwa enfòmasyon sa a nan lang Kreyòl Aisyen, tanpri rele nimewo 772-462-1593.

ESPAÑOL: Si usted desea recibir esta información en español, por favor llame al 772-462-1593.

TABLE OF CONTENTS

<u>SECTION</u>	<u>PAGE</u>
A. INTRODUCTION	
A.1 How to Use the TIP	A-1
A.2 Project Index and TIP/RLRTP Cross Reference	A-2
A.3 TIP Project Location Maps	A-4
A.4 Glossary of Abbreviations and Phase/Funding Source Codes	A-6
A.5 TPO Metropolitan Planning Area Map	A-7
B. NARRATIVE	
B.1 Purpose	B-1
B.2 Financial Plan	B-2
B.3 Project Selection	B-6
B.4 Consistency with Other Plans	B-6
B.5 Project Priority Statement	B-6
B.6 Public Involvement	B-7
B.7 TIP Amendments	B-7
B.8 Annual Listing of Obligated Federal Funding/Implemented Projects	B-8
B.9 Certifications	B-14
B.10 Congestion Management Process (CMP)	B-14
B.11 Transportation Disadvantaged (TD) Program	B-15
B.12 Transportation Regional Incentive Program (TRIP)	B-16
C. DETAILED PROJECT LISTINGS	
C.1 Highway/Roadway/Sidewalk	C 1-1
C.2 Aviation	C 2-1
C.3 Transit Projects	C 3-1
C.4 Miscellaneous Projects	C 4-1
C.5 Planning Projects	C 5-1
C.6 Bridge	C 6-1
C.7 Turnpike Enterprise Projects	C 7-1
D. LIST OF PRIORITY PROJECTS	D-1
E. PERFORMANCE MANAGEMENT	E-1
APPENDICES	
Appendix A: Example Public Comment Notice	
Appendix B: Local Projects City of Fort Pierce	
Appendix C: Local Projects City of Port St. Lucie	
Appendix D: Local Projects: St. Lucie County	
Appendix E: Summary of Comments	
Appendix F: TIP Comparison Table	
Appendix G: TIP Amendment Forms	

A. INTRODUCTION

A.1 HOW TO USE THE TIP

The intent of the Transportation Improvement Program (TIP) is to identify and prioritize the transportation improvement projects over the next five years that are receiving State and Federal funding and are located within the Metropolitan Planning Area (MPA) of the St. Lucie Transportation Planning Organization (St. Lucie TPO). The St. Lucie TPO MPA is identified on the map on page A-7.

To use the TIP:

- Locate the project in the Project Index in Section A.2 or on either of the Project Location Maps in Section A.3 to identify the Project Number or Project Name.
- Using the Project Name, reference directly the alphabetically-listed projects in the Detailed Project Listing pages or, by using the Project Number, identify the TIP Page Number for the project from the Project Index.
- Refer to the corresponding TIP Page Number to obtain information regarding the project in the Detailed Project Listings pages.
- Refer to the corresponding LRTP Page Number in the Project Index or in the Detailed Project Listings pages to cross-reference the project, if applicable, in the SmartMoves 2045 Long Range Transportation Plan (LRTP).
- Refer to Section A.4 for a Glossary of Abbreviations and Phase/Funding Codes.
- Refer to Section B for information on Federal and State requirements for development of the TIP.
- Refer to Section C for the Detailed Project Listings which include whether the project is located on the Florida Strategic Intermodal System (SIS) and the Total Project Cost.
- Refer to Section D for the TPO List of Priority Projects.
- Refer to Section E for an evaluation of project and system performance
- Refer to the Appendices for an Example Public Comment Notice and for information on locally-funded projects and TIP amendments that have been adopted.
- Refer to the contact information on the cover of the TIP if you have any questions or comments.

Explanations of the SIS and Total Project Costs

SIS: The SIS is a network of high priority transportation facilities in Florida which includes the State's largest and most significant commercial service airports, spaceport, deep-water seaports, freight and passenger rail terminals, intercity bus terminals, rail corridors, waterways and highways. All projects on the SIS will have a SIS identifier in the top right corner of the Detailed Project Listings pages in Section C of the TIP.

Total Project Costs: A typical project production sequence is to have a Project Development and Environment (PD&E) phase, followed by a Design (PE) phase, a Right of Way (ROW) phase and a Construction (CST) phase. Some projects may not include a ROW phase if land acquisition is not needed to complete the project. Costs in the Detailed Project Listing pages in Section C of the TIP may include the historical costs (Prior Year Cost), the costs in the five years of the current TIP, the costs in the years beyond the current TIP (Future Year Cost), and the sum of all of these costs which is the Total Project Cost. For some projects such as resurfacing, safety, or operational projects, there may not be a Total Project Cost identified, but additional details on that program will be included.

A.2 PROJECT INDEX AND TIP/RLRTP CROSS REFERENCE

PROJECT NAME	PROJECT LIMITS FROM	PROJECT LIMITS TO	DESCRIPTION	PROJECT NUMBER	L RTP PAGE	TIP PAGE	TIP MAP PAGE
4491791	A1A BIG MUD CREEK AND BLIND CREEK BRIDGES	BIG MUD CREEK BRIDGE	BLIND CREEK BRIDGE	BRIDGE REPLACEMENT	3-9	C 6-2	A-5
4299362	A1A NORTH CAUSEWAY BRIDGE	ENTIRE BRIDGE	ENTIRE BRIDGE	BRIDGE REPLACEMENT	8-3	C 6-3	A-4
4435061	A1A SUNTRAIL	FT PIERCE INLET STATE PARK	SLC/INDIAN RIVER COUNTY LINE	BIKE PATH/TRAIL	8-2	C 1-2	A-4
4533261	CALIFORNIA BLVD	DEL RIO BLVD	CROSTOWN PARKWAY	ADD LANES & RECONSTRUCT	8-11	C 1-3	A-5
4476511	EMERSON AVE	INDRIO RD	25TH ST	RESURFACING	3-9	C 1-4	A-4
4400321	FEC OVERPASS	SAVANNAS RECREATION AREA	SOUTH OF SAVANNAH RD.	BIKE PATH/TRAIL	8-2	C 1-5	A-4
4534951	GATLIN BLVD	@ SAVONA BLVD	@ SAVONA BLVD	ADD TURN LANE(S)	3-9	C 1-6	A-5
4534931	GREEN RIVER PARKWAY TRAIL	WALTON RD	MARTIN COUNTY LINE	BIKE PATH/TRAIL	3-9	C 1-7	A-5
4226816	I-95	SLC/MARTIN COUNTY LINE	SR-70/OKEECHOBEE RD	PD&E/EMO STUDY	8-3	C 1-11	A-4, 5
4443361	I-95 @ ST LUCIE WEST BLVD	@ ST LUCIE WEST BLVD	@ ST LUCIE WEST BLVD	LANDSCAPING	8-2	C 1-8	A-5
4491631	I-95	N OF GLADES CUT-OFF RD	N OF FLORIDA TURNPIKE	RESURFACING	3-9	C 1-9	A-4
4492811	I-95 AT ORANGE AVE	NB EXIT RAMP TO WB ORANGE AVE	NB EXIT RAMP TO WB ORANGE AVE	SKID HAZARD OVERLAY	3-9	C 1-10	A-4
4499611	I-95 REST AREA	ST. LUCIE SB REST AREA	ST. LUCIE SB REST AREA	REST AREA	3-9	C 1-12	A-4
4463311	JENKINS RD	MIDWAY RD	ORANGE AVENUE	PD&E/EMO STUDY	8-3	C 1-13	A-4
4489981	KESTOR DR	DARWIN BOULEVARD	BECKER RD	SIDEWALK	8-11	C 1-14	A-5
4383794	KINGS HWY	N OF I-95 OVERPASS	SOUTH OF ANGLE	ADD LANES & RECONSTRUCT	8-2	C 1-15	A-4
4383792	KINGS HWY	NORTH OF COMMERCIAL CIR	ST LUCIE BLVD	ADD LANES & RECONSTRUCT	8-2	C 1-16	A-4
4383791	KINGS HWY	N OF I-95 OVERPASS	N OF COMMERCIAL CIR	ADD LANES & RECONSTRUCT	8-2	C 1-18	A-4
4383793	KINGS HWY	N OF ST. LUCIE BLVD	INDRIO ROAD	ADD LANES & RECONSTRUCT	8-2	C 1-19	A-4
4529961	MARSHFIELD COURT	SW DREYFUSS BLVD	SW HAYWORTH AVE	BIKE PATH/TRAIL	3-9	C 1-20	A-5
2314404	MIDWAY RD	GLADES CUT OFF RD	JUST WEST OF JENKINS RD	ADD LANES & RECONSTRUCT	8-11	C 1-21	A-4, 5
2314403	MIDWAY RD	GLADES CUT OFF RD	SELVITZ RD	ADD LANES & RECONSTRUCT	8-2	C 1-22	A-4, 5
2314405	MIDWAY RD	JENKINS RD	SELVITZ RD	ADD LANES & RECONSTRUCT	8-11	C 1-23	A-4, 5
4534961	MIDWAY RD	SELVITZ RD	US-1	ATMS - ARTERIAL TRAFFIC MGMT	3-9	C 1-24	A-4, 5
4534921	NEBRASKA AVE	SOUTH LAWNWOOD CIRCLE	SOUTH 13TH ST	SIDEWALK	3-9	C 1-25	A-4
4480661	OLEANDER AVE	SOUTH MARKET AVE	EDWARDS RD	SIDEWALK	3-9	C 1-26	A-4

4461681	ORANGE AVE	KINGS HWY	E OF I-95 SB RAMP	INTERCHANGE - ADD LANES	8-3	C 1-27	A-4
4496961	ORANGE AVE	KINGS HWY	US-1	ATMS - ARTERIAL TRAFFIC MGMT	8-11	C 1-28	A-4
4484481	ORANGE AVE	LAMONT RD	N 32ND ST	RESURFACING	3-9	C 1-29	A-4
4417151	OUTFALL FOR VIRGINIA AVE	OLEANDER BLVD	INDIAN HILLS DR	DRAINAGE IMPROVEMENTS	3-9	C 1-30	A-4
4473991	PORT OF FT. PIERCE SUNTRAIL CONNECTOR	PORT OF FT. PIERCE	PORT OF FT. PIERCE	BIKE PATH/TRAIL	3-9	C 1-31	A-4
4317523	PORT ST. LUCIE BLVD	BECKER RD	PAAR DRIVE	ADD LANES & RECONSTRUCT	8-2	C 1-32	A-5
4317525	PORT ST. LUCIE BLVD	SOUTH OF PAAR DR	SOUTH OF ALCANTARRA BLVD	ADD LANES & RECONSTRUCT	8-2	C 1-33	A-5
4435952	PORT ST. LUCIE BLVD	LONG CREEK	N FORK ST LUCIE RIVER	BRIDGE-REPAIR/REHABILITATION	3-9	C 6-4	A-5
4463761	PORT ST. LUCIE BLVD	SHELTER DR	US-1	RESURFACING	3-9	C 1-34	A-5
4498281	SHOREWINDS DR / A1A	0.2 MILES W OF BR 940046	ATLANTIC BEACH BLVD	RESURFACING	3-9	C 1-35	A-4
4476531	SR-70/OKEECHOBEE RD	IDEAL HOLDING RD	W OF KINGS HWY	RESURFACING	3-9	C 1-36	A-4
4476532	SR-70/OKEECHOBEE RD	MEDIAN CROSSING AT BMP 6.351	IDEAL HOLDING RD	RESURFACING	3-9	C 1-37	A-4
4534911	ST. JAMES DRIVE	NE LAZY RIVER PARKWAY	NE ROYCE AVE	SIDEWALK	3-9	C 1-38	A-4
4484491	ST. LUCIE BLVD	EAST OF N 25 ST	WEST OF US-1	RESURFACING	3-9	C 1-39	A-4
4518581	TURNPIKE AT MIDWAY RD	SOUTHERN RAMPS INTERCHANGE	SOUTHERN RAMPS INTERCHANGE	NEW INTERCHANGE RAMP	3-9	C 7-2	A-4, 5
4465801	TURNPIKE @ SR-70	INTERCHANGE	INTERCHANGE	INTERCHANGE IMPROVEMENT	3-9	C 7-3	A-4
4462201	TURNPIKE AT PORT ST. LUCIE BLVD	INTERCHANGE	INTERCHANGE	INTERCHANGE IMPROVEMENT	3-9	C 7-4	A-5
4510811	TURNPIKE FEEDER ROAD	INDRIO ROAD	US-1	LIGHTING	3-9	C 1-40	A-4
4497121	TURNPIKE PORT ST. LUCIE SERVICE PLAZA	SERVICE PLAZA	SERVICE PLAZA	PARKING IMPROVEMENTS	3-9	C 7-5	A-5
4463341	TURNPIKE WIDENING	MARTIN C/L	BECKER RD	ADD LANES & RECONSTRUCT	3-9	C 7-6	A-5
4465831	TURNPIKE WIDENING	CROSTOWN PKWY	SR70	ADD LANES & RECONSTRUCT	3-9	C 7-7	A-4, 5
4463351	TURNPIKE WIDENING	BECKER RD	CROSTOWN PKWY	ADD LANES & RECONSTRUCT	3-9	C 7-8	A-5
4417141	US HIGHWAY 1	EDWARDS RD	TENNESSEE AVE	DRAINAGE IMPROVEMENTS	3-9	C 1-41	A-4
4484501	US HIGHWAY 1	SOUTH OF JUANITA AVE	NORTH OF KINGS HWY	RESURFACING	3-9	C 1-42	A-4
4476521	US HIGHWAY 1	MARTIN/ST. LUCIE COUNTY LINE	PORT ST. LUCIE BLVD	RESURFACING	3-9	C 1-43	A-5
4510801	US HIGHWAY 1	MIDWAY ROAD	SOUTH OF EDWARDS ROAD	LIGHTING	3-9	C 1-44	A-4
4508611	VOLUCIA DRIVE	EAST TORINO PARKWAY	WEST BLANTON BOULEVARD	SIDEWALK	3-9	C 1-45	A-5

A.3 TIP PROJECT LOCATION MAPS

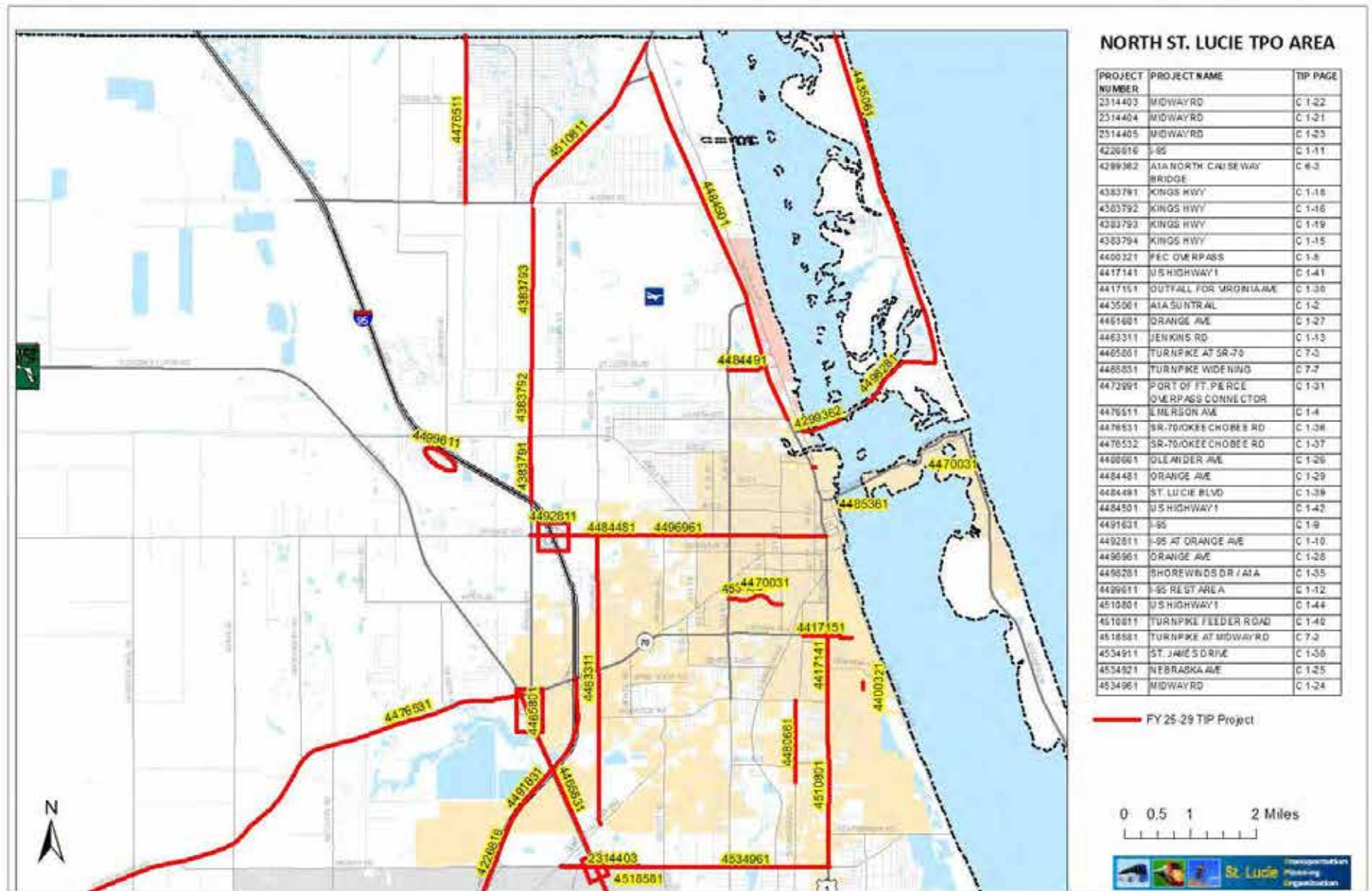

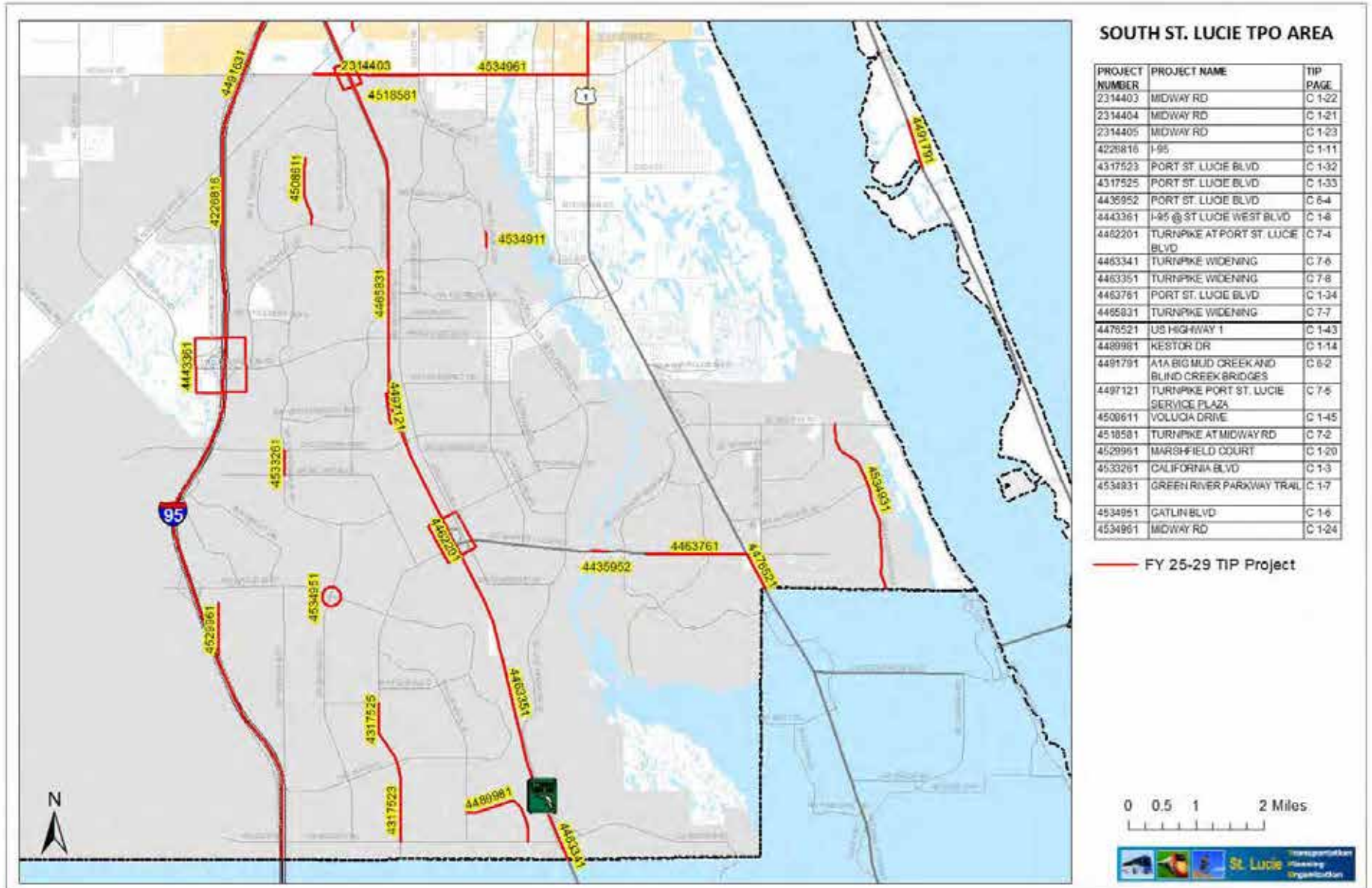

A.4 GLOSSARY OF ABBREVIATIONS AND PHASE/FUNDING SOURCE CODES

ADM	Administration	MNT	Contract Maintenance
BPAC	Bicycle Pedestrian Advisory Committee	MPO	Metropolitan Planning Organization
BRDG	Bridge	MSC	Grant to Local Government
CAC	Citizens Advisory Committee	OPS	Operations
CAP	Capital	PD&E	Project Development and Environmental
CEI	Construction, Engineering, & Inspection	PE	Preliminary Engineering
CIP	Capital Improvements Program	PIP	Public Involvement Program
CLV	Culvert	PLN	Planning
CMP	Congestion Management Process	PST	DES Post Design
CST	Construction	PTO	Public Transportation Office
CTC	Community Transportation Coordinator	RELOC	Right of Way Relocation
DCA	Department of Community Affairs	RLRTP	Regional Long Range Transportation Plan
DSB	Design Build	ROW	Right of Way Support
E/D	Engineering & Design	ROW LND	Right of Way Land
ENV	Environmental	RR	CST Railroad Construction
EPA	Environmental Protection Agency	RRX	Railroad Crossing
FAA	Federal Aviation Administration	RRU	Railroad/Utilities Construction
FDOT	Florida Department of Transportation	SAFETEA-LU	Safe, Accountable, Flexible, Efficient Transportation Equity Act—a Legacy for Users
FHWA	Federal Highway Administration	SLC	St. Lucie County
FTA	Federal Transit Administration	SRA	Senior Resource Association, Inc.
INC	Construction Incentive	TAC	Technical Advisory Committee
IRC	Indian River County	TD	Transportation Disadvantaged
LAR	Local Agency Reimbursement	TDC	Transportation Disadvantaged Commission
LCB	Local Coordinating Board	TIP	Transportation Improvement Program
LOPP	List of Priority Projects	TMA	Transportation Management Area
MAP - 21	Moving Ahead for Progress in the 21st Century	TPO	Transportation Planning Organization
MC	Martin County	UPWP	Unified Planning Work Program
MIT	Mitigation	UTL	Utility Coordination

B. NARRATIVE

B.1 PURPOSE

The purpose of the TIP is to identify and prioritize transportation improvement projects receiving Federal and State funding over a five-year period that are located within the St. Lucie TPO MPA. In addition, the TIP is used to coordinate the transportation improvement projects of the U.S. Department of Transportation (USDOT), the Florida Department of Transportation (FDOT), and the local governments located within the MPA. Projects in the TIP are presented in Year of Expenditure (YOE), which takes into account the inflation rate over the five years in the TIP. Therefore the programmed cost estimate for each project is inflated to the year that the funds are expended based on reasonable inflation factors developed by the State and its partners. The TIP is also used to identify all regionally significant transportation projects for which Federal action is required, whether or not the projects receive Federal funding. As the St. Lucie TPO is in an air quality attainment area, there are no regionally significant air quality-related transportation improvement projects in the TIP.

B.2 Financial Plan

The Financial Plan of the TIP is based upon the FDOT District 4 Tentative Work Program for FY 2024/25 – FY 2028/29; the previous year's TIP; the SmartMoves Long Range Transportation Plan (LRTP); and information provided by St. Lucie County, the City of Port St. Lucie, and the City of Fort Pierce. The Financial Plan includes Federal, State, and local transportation funding sources which are identified in the following tables based on the type of transportation improvement:

B.2 FINANCIAL PLAN

HIGHWAY/ROADWAY/SIDEWALK FUNDING SOURCES

FUND CODE DESCRIPTION	FUND	2025	2026	2027	2028	2029	TOTAL
AC FREIGHT PROG (NFP)	ACFP	406,809	-	-	-	-	406,809
ADVANCE CONSTRUCTION NHPP	ACNP	2,110,000	9,277,647	-	-	7,362,043	18,749,690
AC NAT HWY PERFORM RESURFACING	ACNR	799,951	-	1,701,218	8,665,014	-	11,166,183
AC - PROTECT GRANT PGM	ACPR	1,008,420	-	14,224,592	2,317,855	-	17,550,867
ADVANCE CONSTRUCTION (SS,HSP)	ACSS	-	1,704,738	2,238,159	-	-	3,942,897
ADVANCE CONSTRUCTION (SU)	ACSU	1,772,083	-	-	-	-	1,772,083
CARBON REDUCTION GRANT PGM	CARB	-	-	2,506,627	-	-	2,506,627
CARB FOR URB. AREA > THAN 200K	CARU	562,116	589,129	558,830	78,214	-	1,788,289
CONGRESS GF EARMARKS HIP 2023	CD23	2,000,000	-	-	-	-	2,000,000
COUNTY INCENTIVE GRANT PROGRAM	CIGP	5,548,619	7,094,463	-	-	-	12,643,082
CONGESTION MITIGATION - AQ	CM	-	380,000	-	718,692	-	1,098,692
DISTRICT DEDICATED REVENUE	DDR	27,024,515	10,647,208	15,475,129	27,648,361	42,750	80,837,963
STATE IN-HOUSE PRODUCT SUPPORT	DIH	341,740	432,820	973,621	707,535	95,439	2,551,155
REST AREAS - STATE 100%	DRA	-	2,630,000	1,200,000	-	28,900,000	32,730,000
STATE PRIMARY HIGHWAYS & PTO	DS	9,519,819	18,217	9,584,292	8,991,617	-	28,113,945
FINANCING CORP	FINC	-	100,000	57,818,774	-	-	57,918,774
LOCAL FUNDS	LF	2,058,186	487,673	135,013	-	-	2,680,872
LOCAL FUNDS FOR PARTICIPATING	LFP	3,548,619	-	-	-	-	3,548,619
LOCAL FUNDS/REIMBURSABLE	LFR	-	18,594,737	-	-	-	18,594,737
STP, ANY AREA	SA	7,964,330	4,210,864	11,048,038	12,069,687	-	35,292,919
STP, MANDATORY NON-URBAN <= 5K	SN	91,599	-	-	-	-	91,599
SAFE ROUTES - TRANSFER	SR2T	5,000	-	-	-	-	5,000
STP, URBAN AREAS > 200K	SU	5,088,816	5,515,921	4,273,986	4,431,700	1,000,000	20,310,423
TRANSPORTATION ALTS- <200K	TALL	5,000	-	-	-	-	5,000
TRANSPORTATION ALTS- ANY AREA	TALT	502,046	183,882	1,237,758	-	-	1,923,686
TRANSPORTATION ALTS- >200K	TALU	268,446	810,293	476,416	-	-	1,555,155
SB2514A-TRAIL NETWORK 2015	TLWR	1,160,000	-	4,833,108	7,523,726	-	13,516,834
TRANS REGIONAL INCENTIVE PROGM	TRIP	2,214,712	4,434,962	-	1,403,873	-	8,053,547
SB2514A-TRAN REG INCT PRG 2015	TRWR	1,475,727	1,438,937	-	2,466,127	-	5,380,791
GRAND TOTAL							386,736,238

AVIATION FUNDING SOURCES

FUND CODE DESCRIPTION	FUND	2025	2026	2027	2028	2029	TOTAL
STATE - PTO	DPTO	1,320,000	3,360,475	1,280,000	-	-	5,960,475
FEDERAL AVIATION ADMIN	FAA	-	368,550	-	-	-	368,550
LOCAL FUNDS	LF	330,000	855,475	320,000	-	-	1,505,475
GRAND TOTAL							7,834,500

TRANSIT OPERATIONS FUNDING SOURCES

FUND CODE DESCRIPTION	FUND	2025	2026	2027	2028	2029	TOTAL
DISTRICT DEDICATED REVENUE	DDR	1,590,467	991,520	817,389	841,911	841,911	5,083,198
STATE - PTO	DPTO	572,174	300,000	-	-	-	872,174
STATE PRIMARY/FEDERAL REIMB	DU	81,206	85,029	89,038	93,058	93,058	441,389
FEDERAL TRANSIT ADMINISTRATION	FTA	2,695,000	2,695,000	2,695,000	2,695,000	2,695,000	13,475,000
LOCAL FUNDS	LF	1,043,847	1,076,549	906,427	934,969	934,969	4,896,761
GRAND TOTAL							24,768,522

MISCELLANEOUS FUNDING SOURCES

FUND CODE DESCRIPTION	FUND	2025	2026	2027	2028	2029	TOTAL
UNRESTRICTED STATE PRIMARY	D	1,755,000	1,755,000	1,835,000	2,811,946	2,819,238	10,976,184
DISTRICT DEDICATED REVENUE	DDR	160,123	242,938	353,661	-	-	756,722
STATEWIDE ITS - STATE 100%.	DITS	521,485	479,566	412,193	-	-	1,413,244
PRIMARY/FIXED CAPITAL OUTLAY	FCO	175,000	325,000	410,000	80,000	25,000	1,015,000
GRAND TOTAL							14,161,150

PLANNING FUNDING SOURCES

FUND CODE DESCRIPTION	FUND	2025	2026	2027	2028	2029	TOTAL
ADVANCE CONSTRUCTION (SU)	ACSU	400,000	-	-	-	-	400,000
METRO PLAN (85% FA; 15% OTHER)	PL	803,048	812,581	812,581	812,581	812,581	4,053,372
STP, URBAN AREAS > 200K	SU	-	400,000	400,000	400,000	400,000	1,600,000
GRAND TOTAL							6,053,372

BRIDGE FUNDING SOURCES

FUND CODE DESCRIPTION	FUND	2025	2026	2027	2028	2029	TOTAL
ADVANCE CONSTRUCTION (BRT)	ACBR	1,129,000	16,447,497	-	-	-	17,576,497
STATE BRIDGE REPAIR & REHAB	BRRP	3,210,276	-	-	-	-	3,210,276
UNRESTRICTED STATE PRIMARY	D	40,000	40,000	40,000	40,000	-	160,000
STATE IN-HOUSE PRODUCT SUPPORT	DIH	12,605	-	-	-	-	12,605
GEN FUND BRIDGE REPAIR/REPLACE	GFBR	8,676,339	-	-	-	-	8,676,339
GRAND TOTAL							29,635,717

TURNPIKE ENTERPRISE FUNDING SOURCES

FUND CODE DESCRIPTION	FUND	2025	2026	2027	2028	2029	TOTAL
TURNPIKE IMPROVEMENT	PKYI	18,572,271	29,983,654	17,301,911	270,000	-	66,127,836
GRAND TOTAL							66,127,836

FINANCIAL PLAN GRAND TOTAL 535,317,335

The TIP is financially constrained each year with the project cost estimates equal to the funding source estimates as demonstrated in the Financial Summary below:

PROJECT FUNDING SOURCE ESTIMATES	2025	2026	2027	2028	2029	Total Program
Highway/Roadway/Sidewalk	75,476,553	68,551,491	128,285,561	77,022,401	37,400,232	386,736,238
Aviation	1,650,000	4,584,500	1,600,000	0	0	7,834,500
Transit Operations	5,982,694	5,148,098	4,507,854	4,564,938	4,564,938	24,768,522
Miscellaneous	2,611,608	2,802,504	3,010,854	2,891,946	2,844,238	14,161,150
Planning	1,203,048	1,212,581	1,212,581	1,212,581	1,212,581	6,053,372
Bridge	13,068,220	16,487,497	40,000	40,000	0	29,635,717
Turnpike Enterprise	18,572,271	29,983,654	17,301,911	270,000	0	66,127,836
						535,317,335

PROJECT COST ESTIMATES	2025	2026	2027	2028	2029	Total Program
Highway/Roadway/Sidewalk	75,476,553	68,551,491	128,285,561	77,022,401	37,400,232	386,736,238
Aviation	1,650,000	4,584,500	1,600,000	0	0	7,834,500
Transit Operations	5,982,694	5,148,098	4,507,854	4,564,938	4,564,938	24,768,522
Miscellaneous	2,611,608	2,802,504	3,010,854	2,891,946	2,844,238	14,161,150
Planning	1,203,048	1,212,581	1,212,581	1,212,581	1,212,581	6,053,372
Bridge	13,068,220	16,487,497	40,000	40,000	0	29,635,717
Turnpike Enterprise	18,572,271	29,983,654	17,301,911	270,000	0	66,127,836
						535,317,335

FUND SOURCE	2025	2026	2027	2028	2029	Total Program
Federal	34,369,209	43,481,131	42,262,243	32,281,801	12,362,682	164,757,066
Federal Earmark	2,000,000	0	0	0	0	2,000,000
Local	6,980,652	21,014,434	1,361,440	934,969	934,969	31,226,464
State 100%	56,642,262	34,291,106	95,033,167	52,515,096	32,724,338	271,205,969
Toll/Turnpike	18,572,271	29,983,654	17,301,911	270,000	0	66,127,836
GRAND TOTAL FROM ALL JURISDICTIONS	118,564,394	128,770,325	155,958,761	86,001,866	46,021,989	35,317,335
						535,317,335

Note: See Section A-8 for Fund Code Source and Fund Code Description

B.3 PROJECT SELECTION

The selection of federally-funded projects within the St. Lucie TPO MPA for the TIP is consistent with Federal regulations [23 CFR450.330(c)] and is carried out by the TPO in cooperation with FDOT and the transit operator. The TIP has been developed in coordination with the USDOT, FDOT, St. Lucie TPO Advisory Committees, local governments, port and aviation authorities, transit operators, and the general public as summarized in Section B.6 of the TIP.

For the TPO's FY 2024/25 - FY 2028/29 TIP, the project selection and TIP development process started in May 2023. The List of Priority Projects (LOPP) was developed based on the LRTP and other plans as identified in Section B.4, local agency input, and public comments. The LOPP was reviewed by the St. Lucie TPO Advisory Committees and was adopted by the St. Lucie TPO Board and submitted to FDOT District 4 in June 2023. The LOPP was utilized by FDOT District 4 to develop their Draft Tentative Work Program for FY 2024/25 -FY 2028/29. The Draft Tentative Work Program was reviewed and endorsed by the Board in October 2023. The Final Tentative Work Program was received from FDOT in April of 2024. The Final Tentative Work Program is the primary component of the TIP. The TPO LOPP is reproduced in Section D of the TIP.

B.4 CONSISTENCY WITH OTHER PLANS

The projects in the TIP are based on the LRTP, the St. Lucie Transit Development Plan, the Transportation Disadvantaged Service Plan/ Coordinated Public Transit – Human Services Transportation Plan, and other transportation plans of the St. Lucie TPO. These plans are cross-referenced in the LOPP, and the TIP projects are cross-referenced with the LRTP in the Project Index and TIP/LRTP Cross Reference in Section A.2. The projects also are consistent with the St. Lucie County Airport Master Plan, the Port of Fort Pierce Master Plan, and the 2060 Florida Transportation Plan.

In addition, the TIP has been developed to be consistent with adopted local Comprehensive Plans including the St. Lucie County, City of Fort Pierce, City of Port St. Lucie, and St. Lucie Village Comprehensive Plans. The transportation network in the TPO MPA contains the traffic circulation elements included in the adopted St. Lucie County, City of Fort Pierce, City of Port St. Lucie, and St. Lucie Village Comprehensive Plans. Projections of future traffic volumes and levels of service were developed based on the Future Land Use Elements of the respective plans. The projections, as identified in the LRTP, served as a basis for determining the need for new or expanded transportation facilities and transportation management systems to support proposed development and to maintain or improve adopted level of service standards.

B.5 PROJECT PRIORITY STATEMENT

The projects selected in the TIP are based upon the TPO LOPP and the corresponding prioritization methodology and the goals, objectives and performance measures identified in Table 3-1 of the LRTP. The project prioritization was based on qualitative and quantitative analyses of the transportation projects in the TPO MPA which included the scoring and ranking of multimodal project priorities as identified in Table 7-1 and Appendix E of the LRTP. The project priorities were further refined with the development of alternatives and scenarios planning as summarized in Chapter 7 of the LRTP and the consideration of public comment as summarized in Chapter 8 of the LRTP.

B.6 PUBLIC INVOLVEMENT

Public involvement in the development of the LOPP and the TIP is continuous, cooperative, and comprehensive and was conducted in accordance with the adopted Public Involvement Program (PIP) of the St. Lucie TPO and with Federal regulations [23 CFR 450.316 and 23 CFR 450.324(b)]. Reasonable opportunity to comment on the LOPP and the TIP was provided to all interested parties including, but not limited to, citizens, affected public agencies, public transit providers, freight shippers, private transportation providers, bicycle/pedestrian representatives, and the disabled. The process included those traditionally underserved and underrepresented consistent with the principles of Title VI. The process is followed for all projects funded in whole or part by the Federal Transit Administration (FTA) or the Federal Highway Administration (FHWA) pursuant to the Federal requirements.

B.7 TIP AMENDMENTS

TIP Amendments are completed in accordance with applicable requirements [23 CFR 324 and 326] when a project is added or deleted, when the fiscal constraint of the TIP is impacted by a project, and/or when there are significant changes in the scope of a project. The amendment of the TIP includes the preparation of a TIP Amendment Form that summarizes the nature of the changes.

Prior to the adoption of a TIP amendment by the TPO Board, notice and public comment opportunities are provided regarding the amendment consistent with Section B.6. Upon adoption of the amendment by the TPO Board, the TIP Amendment Form is incorporated into Appendix G of the TIP.

B.8 ANNUAL LISTING OF OBLIGATED FEDERAL FUNDING/IMPLEMENTED PROJECTS

FHWA OBLIGATED FUNDING

PROJECT NUMBER	PROJECT NAME	DESCRIPTION	LENGTH	FUND TOTAL	FUND CODE	PROJECT TOTAL
230256 6	SR-713/KINGS HWY FR 500 FT S OF SR-70 TO NORTH OF PICOS ROAD	ADD LANES & RECONSTRUCT	2.200	183,355	GFSU	
				480,097	GFSU	
				-13,253	SA	
				4,501	SU	
				3,676	GFSU	
				-89,520	SU	568,856
231440 2	W. MIDWAY RD/CR-712 FROM S. 25TH STREET/SR-615 TO SR-5/US-1	ADD LANES & RECONSTRUCT	1.803	3,215	CM	
				-434,382	GFSU	
				-141,361	SA	
				32,268	SU	
				-79,452	SU	-619,712
231440 3	W MIDWAY RD/CR-712 FROM GLADES CUT OFF ROAD TO SELVITZ ROAD	ADD LANES & RECONSTRUCT	1.577	6,317	SA	6,317
231440 5	W MIDWAY/CR-712/FROM JUST WEST OF JENKINS RD TO SELVITZ RD	ADD LANES & RECONSTRUCT	0.785	51,400	SU	51,400
428728 1	SR-5/US-1 FROM N. OF MIDWAY RD TO EDWARDS RD	RESURFACING	2.362	189,831	SA	189,831
429936 2	SR-A1A NORTH BRIDGE OVER ICWW BRIDGE #940045	BRIDGE REPLACEMENT	1.205	22,824	SA	
				1,000	NHBR	
				1,721,784	NHBR	

PROJECT NUMBER	PROJECT NAME	DESCRIPTION	LENGTH	FUND TOTAL	FUND CODE	PROJECT TOTAL
				284,773	SA	
				29,000	SA	2,059,381
4299362	SR-A1A NORTH BRIDGE OVER ICWW BRIDGE #940045	BRIDGE REPLACEMENT	1.205	274,036	GFBR	274,036
431752 2	PORT ST. LUCIE BLVD FROM PAAR DRIVE TO DARWIN BLVD	ADD LANES & RECONSTRUCT	1.946	122,803	SA	
				781,467	SA	
				-106,282	SU	797,988
4317523	PORT ST. LUCIE BLVD FROM BECKER ROAD TO PAAR DRIVE	ADD LANES & RECONSTRUCT	1.119	26,145	SU	
				4,000	GFSU	
				-4,350	SA	
				250,164	SU	
				323,760	SU	599,719
4317526	PORT ST.LUCIE BLVD FROM SOUTH OF ALCANTARRA BV TO SOUTH OF DARWIN BLVD	ADD LANES & RECONSTRUCT	0.713	2,345,432	SU	2,345,432
4368681	SR-5/US-1 @ SR-70/VIRGINIA AVENUE	ADD RIGHT TURN LANE(S)	0.071	-53,192	SU	-53,192
4383791	SR-713/KINGS HWY FR N OF SR-9/I-95 OVERPASS TO N OF COMMERCIAL CIR	ADD LANES & RECONSTRUCT	1.400	1,878,317	SU	1,878,317
4383792	SR-713/KINGS HWY FROM N OF COMMERCIAL CIRCLE TO NORTH OF ST LUCIE BLVD	ADD LANES & RECONSTRUCT	1.210	34,298	SU	
				363,993	SU	398,291
4398471	SR-5/US-1 FROM S. OF PORT ST. LUCIE BLVD. TO NE RIOMAR DRIVE	RESURFACING	4.987	-55,767	GFSA	
				343,261	HSP	

PROJECT NUMBER	PROJECT NAME	DESCRIPTION	LENGTH	FUND TOTAL	FUND CODE	PROJECT TOTAL
				-17,314	SA	270,180
4415661	OLEANDER AVENUE FROM MIDWAY ROAD TO SOUTH MARKET AVENUE	SIDEWALK	1.257	-4,085	TALU	-4,085
4438471	SR-9/I-95 FROM NORTH OF GATLIN BLVD TO SOUTH OF ST. LUCIE WEST BLVD	SKID HAZARD OVERLAY	3.198	7,783,802	HSP	
				1,160,924	SU	
				2,163	HSP	8,946,889
4443481	CURTIS STREET FROM NW PRIMA VISTA BLVD TO NW FLORESTA DRIVE	SIDEWALK	0.543	-4,855	TALT	-4,855
4443491	ALCANTARRA BLVD FROM SW SAVONA BLVD TO SW PORT ST.LUCIE BLVD	SIDEWALK	0.800	-34	TALU	-34
4447071	GATLIN BLVD FROM SW VILLAGE PARKWAY TO SAVONA BLVD	TRAFFIC CONTROL DEVICES/SYSTEM	2.672	238,633	GFSU	
				14,000	GFSU	
				238,622	SU	
				14,000	SU	
				324	SU	505,579
4460741	SELVITZ ROAD FROM NORTHWEST FLORESTA DRIVE TO NORTHWEST BAYSHORE BLVD	BIKE LANE/SIDEWALK	0.482	161,824	TALT	
				18,000	TALT	
				265,963	TALU	
				-2,797	TALT	442,990
4460761	BELL AVENUE FROM SOUTH 25TH STREET TO SUNRISE BLVD	BIKE LANE/SIDEWALK	0.400	17,807	SU	

PROJECT NUMBER	PROJECT NAME	DESCRIPTION	LENGTH	FUND TOTAL	FUND CODE	PROJECT TOTAL
				12,305	TALT	
				217,909	TALT	
				4,089	TALU	
				-3,054	TALT	249,056
4461681	SR-68/ORANGE AVE FROM SR-713/KINGS HWY TO E OF SR-9/I-95 SB RAMP	INTERCHANGE - ADD LANES	0.646	614,283	NFP	614,283
4461691	SR-68/ORANGE AVENUE FROM N 32ND ST TO WEST OF SR-5/US-1	RESURFACING	1.915	2,765,720	SA	
				1,000,105	SN	
				172,885	SU	3,938,710
4463311	JENKINS ROAD FROM CR-712/MIDWAY ROAD TO SR-68/ORANGE AVENUE	PD&E/EMO STUDY	2.128	359,119	GFSU	
				366,974	SU	726,093
4470031	INTERSECTION LIGHTING RETROFIT IMPROVEMENT	LIGHTING	2.441	136,006	HSP	136,006
4481341	PORT ST LUCIE TSM&O VARIOUS LOCATIONS	ITS COMMUNICATION SYSTEM	0.990	13,899	GFSU	
				296,627	GFSU	310,526
4489981	SW KESTOR DRIVE FROM SW DARWIN BOULEVARD TO SW BECKER ROAD	SIDEWALK	1.389	5,000	TALT	5,000
4491631	SR-9/I-95 N OF GLADES CUT-OFF RD TO N OF FLORIDA TURNPIKE/SR-91	RESURFACING	2.756	145,934	GFSA	
				5,000	SA	150,934
4492811	NB SR-9/I-95 EXIT RAMP TO WB SR-68/ORANGE AVENUE	SKID HAZARD OVERLAY	0.583	28,437	SA	28,437
4393263	ST. LUCIE FY 2020/2021-2021/2022 UPWP	TRANSPORTATION PLANNING	0.000	-122,937	PL	

PROJECT NUMBER	PROJECT NAME	DESCRIPTION	LENGTH	FUND TOTAL	FUND CODE	PROJECT TOTAL
				-51	SU	-122,988
4393264	ST. LUCIE FY 2022/2023-2023/2024 UPWP	TRANSPORTATION PLANNING	0.000	356,183	GFSU	
				756,682	PL	
				400,000	SU	1,512,865
GRAND TOTAL						26,202,250

FTA OBLIGATED FUNDING

FTA GRANT NUMBER	COUNTY	FTA GRANTEE	FEDERAL FUND CODE	FTA PROJECT DESCRIPTION	TOTAL FTA FUNDS IN TIP	TOTAL FEDERAL FUNDS OBLIGATED	TOTAL LOCAL FUNDS	TOTAL
1024-23-01	SLC	SLC	5307	Capital/Operating	\$2,420,000	\$3,670,009	\$1,846,600	\$7,936,609
1024-23-01	SLC	SLC	5339	Bus and Bus Facilities	\$275,000	\$297,837	\$0	\$572,837
	SLC	SLC	5311	Operating	\$162,412	\$0	\$61,004	\$284,420
	SLC	SLC	5310	Elderly and individuals with disabilities	\$0	\$500,909	\$277,671	\$778,580
TOTAL					\$2,857,412	\$4,529,759	\$2,185,275	\$9,572,446

B.9 CERTIFICATIONS

To ensure Federal requirements are being met, the FHWA and FTA conduct Federal certification reviews on a quadrennial basis of the urbanized areas of TPOs/MPOs which also are designated by census as Transportation Management Areas (TMAs) because the population exceeds 200,000 people. The urbanized area of the St. Lucie TPO is designated as the Port St. Lucie TMA. The last Federal review of the TMA was completed in September 2021 and resulted in no corrective actions, five noteworthy practices, and two recommendations were identified to improve the current planning process of the TPO.

The TPO and FDOT also perform joint certification reviews annually to ensure that State and Federal requirements are being met. The last joint certification review was completed in February 2024 which resulted in the joint certification of the St. Lucie TPO. Support documentation concerning the Federal and joint certification reviews is on file at the St. Lucie TPO offices and available for review during normal business hours.

B.10 CONGESTION MANAGEMENT PROCESS (CMP)

The development and implementation of a CMP is a requirement to be eligible for Federal funding. CMP Box Funds in the amount of \$300,000 - \$400,000 annually have been established by the St. Lucie TPO. Beyond the five fiscal years of the TIP, the LRTP continues to allocate approximately \$3.25 million in funding towards the CMP on a yearly basis through 2045.

The overall purpose of the St. Lucie TPO CMP is to create a better quality of life for St. Lucie residents and visitors through lowering travel delay, reducing harmful emissions, and improving safety. The CMP identifies areas with congestion or safety issues, develops strategies to address the issues, and prioritizes projects based a ranking criteria.

The St. Lucie TPO CMP was adopted in 2018, and a two-tiered approach (Phase I and Phase II) was utilized in the CMP to identify projects. The Phase I analysis provided a system-wide screening for areas of concern. The Phase II analysis included a detailed evaluation of the identified areas of concern. Based on the results of the Phase II evaluation, CMP projects were identified, and a project scoring criteria and the basis for the CMP Implementation Plan were developed.

Incorporating multimodal performance measures, the CMP Implementation Plan utilizes both traditional and non-traditional strategies to address the areas of concern, to reduce vehicle miles traveled, and to consider climate adaptation and proposes improvements which support multimodal elements and safety. The CMP projects from the CMP Implementation Plan that are not funded in the TIP may be added to CMP List of the TPO's LOPP for future funding with the CMP Box Funds.

B.11 TRANSPORTATION DISADVANTAGED (TD) PROGRAM

TD services are facilitated by the St. Lucie TPO pursuant to Florida Statute 427.015. The projects and costs of the St. Lucie TPO TD Program are summarized in the following:

Commission for the Transportation Disadvantaged								
Trip & Equipment Grant Allocations								
FY 2024-2025								
COUNTY	TRIP/EQUIP GRANT	LOCAL TRIP/EQUIP MATCH	TOTAL TRIP/EQUIP FUNDS	VOLUNTARY DOLLARS FM/Job # 43202818401	VOLUNTARY DOLLARS LOCAL MATCH	TOTAL VOLUNTARY DOLLARS	PLANNING GRANT ALLOCATION	TOTAL ESTIMATED PROJECT FUNDING
Saint Lucie	\$715,364	\$79,484	\$794,848	\$64	\$7	\$71	\$29,741	\$824,660

B.12 TRANSPORTATION REGIONAL INCENTIVE PROGRAM (TRIP)

In 2005, the Florida Legislature enacted the Florida TRIP through Senate Bill 360. The stated purpose of the program is to encourage regional planning by providing state matching funds for improvements to regionally-significant transportation facilities identified and prioritized by regional partners. According to FDOT, two primary program requirements are as follows:

- Eligible recipients must be a partner, through an Interlocal Agreement, to a regional transportation planning entity; and,
- The partners must represent a regional transportation planning area and develop a plan that identifies and prioritizes regionally significant facilities.

To satisfy the application requirements for TRIP funding, an Interlocal Agreement was executed by the St. Lucie TPO, Martin MPO, and Indian River MPO to create a regional transportation planning entity known as the Treasure Coast Transportation Council (TCTC). The TCTC subsequently adopted a plan to identify and prioritize regionally significant facilities for the selection of projects for TRIP funding. This plan subsequently was updated in 2023.

St. Lucie TPO projects currently programmed in this TIP include \$8,053,547 of TRIP funding. The MIDWAY RD project (#2314405) is receiving \$3,276,644 in TRIP funding, and the PORT ST. LUCIE BLVD projects (#4317523 and #4317525) is receiving \$4,776,903.

C. DETAILED PROJECT LISTINGS

C.1 HIGHWAY/ROADWAY/SIDEWALK

A1A SUNTRAIL
4435061 Non-SIS

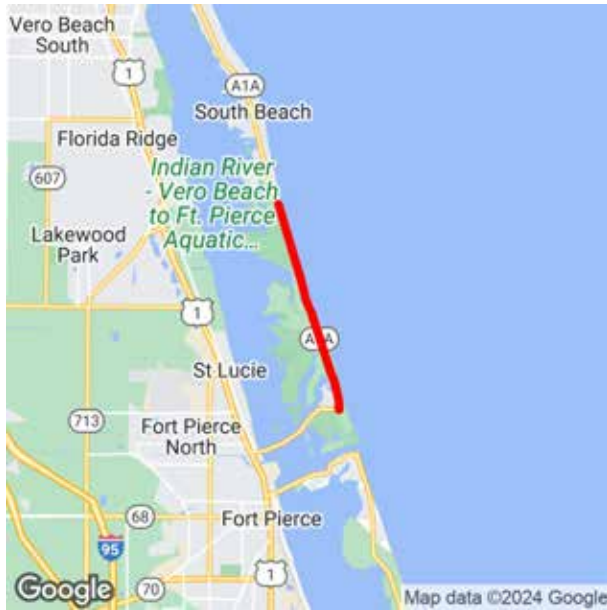

Project Description: BIKE PATH/TRAIL
Extra Description: SUNTRAIL: ST. LUCIE COUNTY NORTH A1A INDIAN RIVER LAGOON TRAIL IMPROVEMENT
Lead Agency: MANAGED BY FDOT **From:** FT PIERCE INLET STATE PARK
County: ST. LUCIE **To:** SLC/INDIAN RIVER COUNTY LINE
Length: 5.193
Phase Group: P D & E, PRELIMINARY ENGINEERING, CONSTRUCTION, ENVIRONMENTAL

Phase	Fund Code	2025	2026	2027	2028	2029	Total
CST	TLWR	0	0	0	7,523,726	0	7,523,726
					7,523,726		7,523,726

Prior Year Cost: 1,656,005
Future Year Cost: 0
Total Project Cost: 9,179,731
LRTP: Page 8-2

CALIFORNIA BLVD FROM DEL RIO TO CROSSTOWN PARKWAY
4533261 Non-SIS

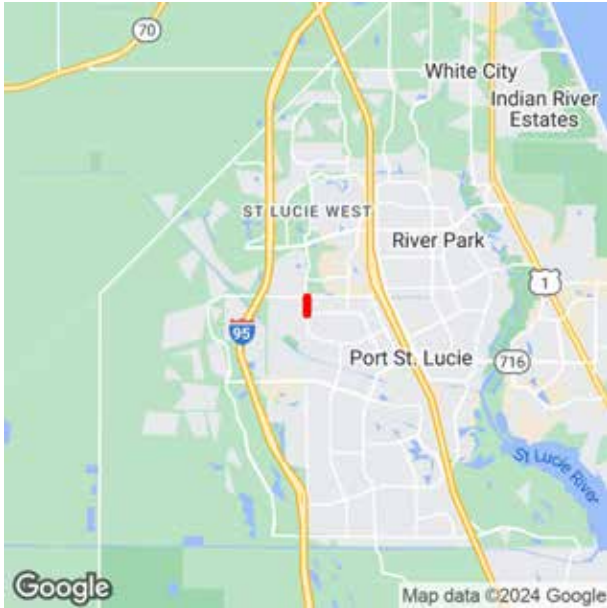

Project Description: ADD LANES & RECONSTRUCT
Extra Description: 2024 TPA PRIORITY # 7 ADD 2 LANES AND SHARED-USE PATHS
Lead Agency: MANAGED BY FDOT **From:** DEL RIO
Length: 2.476 **To:** CROSSTOWN PARKWAY
Phase Group: P D & E

Phase	Fund Code	2025	2026	2027	2028	2029	Total
PDE	SU	0	0	0	0	500,000	500,000
						500,000	500,000

Prior Year Cost: 0
Future Year Cost: 0
Total Project Cost: 500,000
LRTP: Page 8-11

**EMERSON AVE FROM NORTH OF INDRIO RD TO SOUTH OF 25TH ST SW
4476511 Non-SIS**

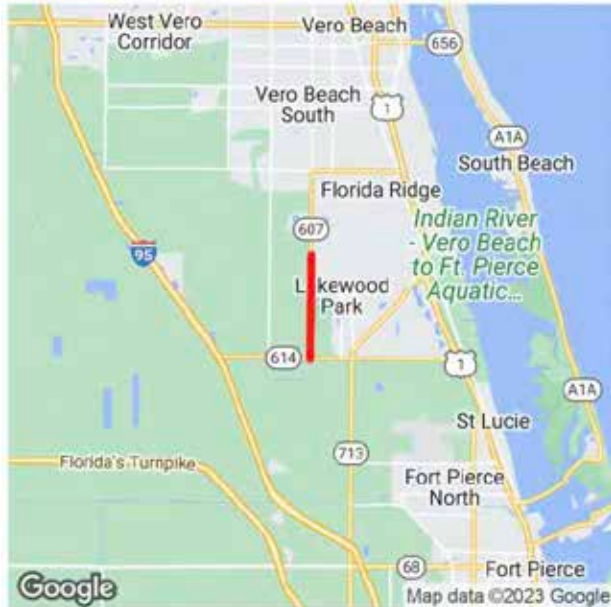

Project Description: RESURFACING

Lead Agency: MANAGED BY FDOT

County: ST. LUCIE

Length: 2.238

Phase Group: PRELIMINARY ENGINEERING, CONSTRUCTION, ENVIRONMENTAL

From: NORTH OF INDRIO RD

To: SOUTH OF 25TH ST SW

Phase	Fund Code	2025	2026	2027	2028	2029	Total
CST	ACPR	1,008,420	0	0	0	0	1,008,420
CST	DDR	2,185,414	0	0	0	0	2,185,414
CST	DS	658,619	0	0	0	0	658,619
CST	DS	1,316,012	0	0	0	0	1,316,012
CST	SA	2,184,187	0	0	0	0	2,184,187
		7,352,652					7,352,652

Prior Year Cost: 679,686

Future Year Cost: 0

Total Project Cost: 8,032,338

LRTP: Page 3-9

FEC OVERPASS FROM SAVANNAS RECREATION AREA TO SOUTH OF SAVANNAH RD

4400321 Non-SIS

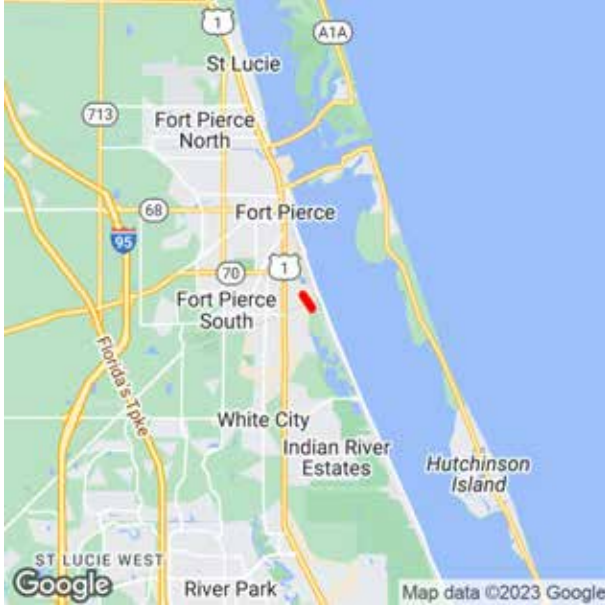

Project Description: BIKE PATH/TRAIL

Extra Description: SUNTRAIL

Lead Agency: MANAGED BY FDOT

County: ST. LUCIE

Length: 0

Phase Group: P D & E, PRELIMINARY ENGINEERING, RIGHT OF WAY, RAILROAD & UTILITIES, CONSTRUCTION, ENVIRONMENTAL

From: SAVANNAS RECREATION AREA

To: SOUTH OF SAVANNAH RD

Phase	Fund Code	2025	2026	2027	2028	2029	Total
ROW	DS	25,000	18,217	0	0	0	43,217
RRU	TLWR	60,000	0	0	0	0	60,000
CST	DIH	0	0	104,312	0	0	104,312
CST	TLWR	0	0	4,833,108	0	0	4,833,108
		85,000	18,217	4,937,420			5,040,637

Prior Year Cost: 821,924

Future Year Cost: 0

Total Project Cost: 5,862,561

LRTP: Page 8-2

GATLIN BLVD @ SAVONA BLVD
4534951 Non-SIS

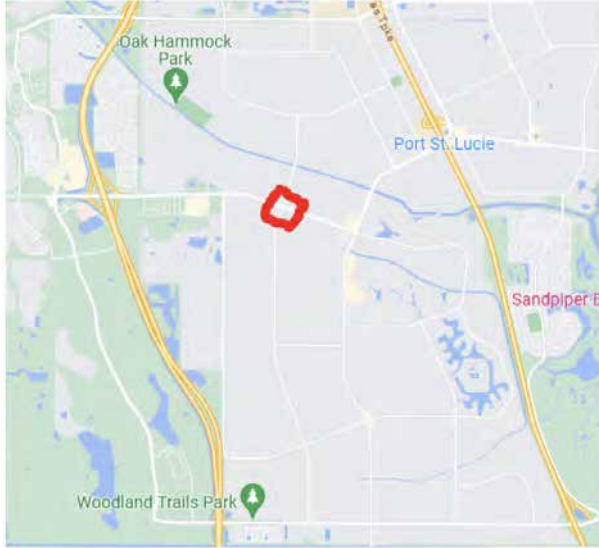

Project Description: ADD TURN LANE(S)
Extra Description: 2024 TPO PRIORITY 2 CARBON REDUCTION PROGRAM 2024 TPA CARBON REDUCTION PRIORITY #2 EXTEND EASTBOUND & WESTBOUND LEFT-TURN LANES ON GATLIN BLVD & INSTALL DEDICATED NORTHBOUND & SOUTHBOUND RIGHT-TURN LANES
Lead Agency: MANAGED BY FDOT **From:** GATLIN BLVD
County: ST. LUCIE **To:** SAVONA BLVD
Length: 0.12
Phase Group: PRELIMINARY ENGINEERING, CONSTRUCTION

Phase	Fund Code	2025	2026	2027	2028	2029	Total
CST	CARU	562,116	0	0	0	0	562,116
CST	LF	61,769	0	0	0	0	61,769
		623,885					623,885

Prior Year Cost: 5,000
Future Year Cost: 0
Total Project Cost: 628,885
LRTP: Page 8-11

GREEN RIVER PARKWAY TRAIL FROM WALTON RD TO MARTIN COUNTY LINE
4534931 Non-SIS

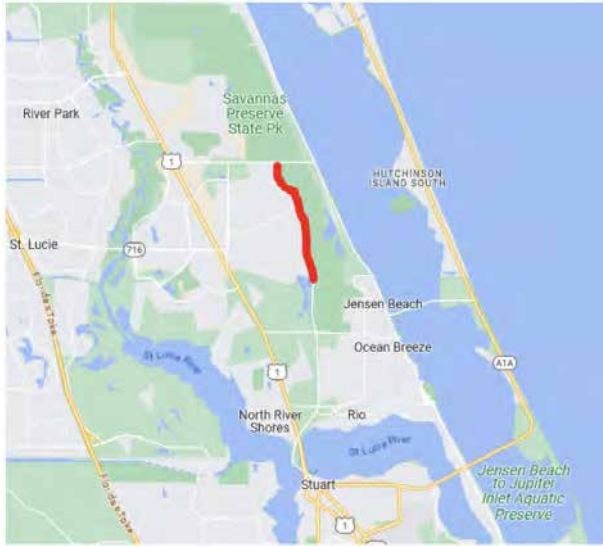

Project Description: BIKE PATH/TRAIL
Extra Description: 2024 TPA CARBON REDUCTION PRIORITY #3 RESURFACING OF MULTI-USE PATH: 2.5 MILES
Lead Agency: MANAGED BY FDOT **From:** WALTON RD
County: ST. LUCIE **To:** MARTIN COUNTY LINE
Length: 2.648
Phase Group: PRELIMINARY ENGINEERING, CONSTRUCTION

Phase	Fund Code	2025	2026	2027	2028	2029	Total
CST	CARU	0	239,151	0	0	0	239,151
CST	LF	0	20,000	0	0	0	20,000
		259,151					259,151

Prior Year Cost: 5,000
Future Year Cost: 0
Total Project Cost: 264,151
LRTP: Page 3-9

I-95 @ ST LUCIE WEST BLVD
4443361 SIS



Project Description: LANDSCAPING

Lead Agency: MANAGED BY FDOT

County: ST. LUCIE

Length: 1.42

Phase Group: PRELIMINARY ENGINEERING, CONSTRUCTION

From: I-95

To: ST. LUCIE WEST BLVD

Phase	Fund Code	2025	2026	2027	2028	2029	Total
PE	DIH	12,705	0	0	0	0	12,705
CST	DDR	1,030,803	0	0	0	0	1,030,803
CST	DIH	39,220	0	0	0	0	39,220
		1,082,728					1,082,728

Prior Year Cost: 157,298

Future Year Cost: 0

Total Project Cost: 1,240,026

LRTP: Page 8-2

I-95 FROM N OF GLADES CUT-OFF RD TO N OF FLORIDA TURNPIKE
4491631 SIS

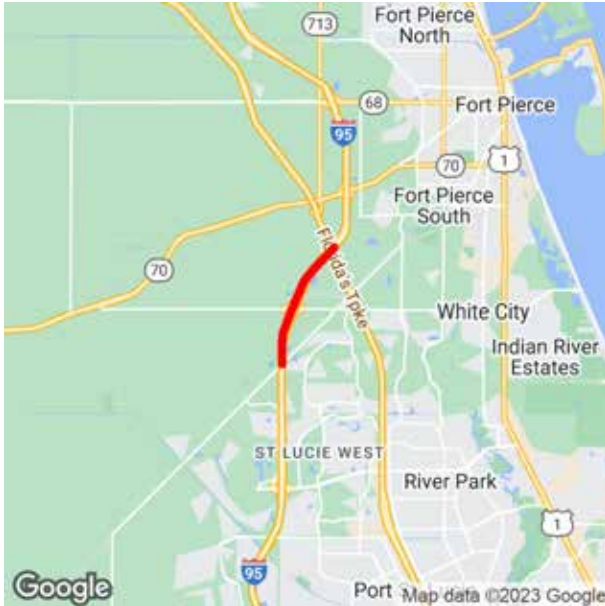

Project Description: RESURFACING

Lead Agency: MANAGED BY FDOT

County: ST. LUCIE

Length: 2.756

Phase Group: PRELIMINARY ENGINEERING, CONSTRUCTION

From: N OF GLADES CUT-OFF RD

To: N OF FLORIDA TURNPIKE

Phase	Fund Code	2025	2026	2027	2028	2029	Total
CST	ACNP	0	9,277,647	0	0	0	9,277,647
CST	DDR	0	1,309,230	0	0	0	1,309,230
CST	DIH	0	114,013	0	0	0	114,013
		10,700,890					10,700,890

Prior Year Cost: 907,853

Future Year Cost: 0

Total Project Cost: 11,608,743

LRTP: Page 3-9

I-95 FROM NB EXIT RAMP TO WB ORANGE AVE
4492811 SIS

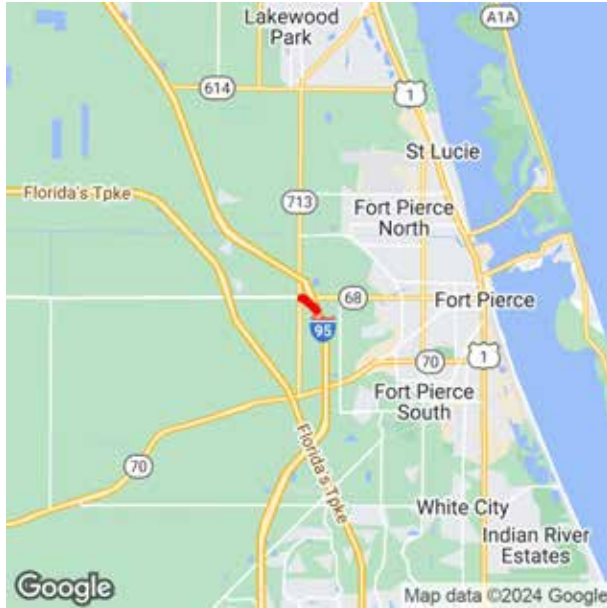

Project Description: SKID HAZARD OVERLAY
Extra Description: SYSTEMATIC LOOP RAMPS SAFETY ASSESSMENT- NPV=1,508,527; B/C=3.5; WIDEN THE OUTSIDE PAVED SHOULDER ALONG THE RAMP MILL AND RESURFACE THE RAMP WITH HIGH FRICTION SURFACE ENHANCE EXISTING LIGHTING ALONG THE RAMP (BY RE-LAMPING WITH LED LIGHTS) SHSP EMPHASIS AREA- LANE DEPARTURE CRASHES
Lead Agency: MANAGED BY FDOT **From:** NB EXIT RAMP TO WB ORANGE AVE
Length: 0.583 **To:** NB EXIT RAMP TO WB ORANGE AVE
Phase Group: PRELIMINARY ENGINEERING, CONSTRUCTION

Phase	Fund Code	2025	2026	2027	2028	2029	Total
CST	ACSS	0	661,343	0	0	0	661,343
CST	SA	0	29,045	0	0	0	29,045
			690,388				690,388

Prior Year Cost: 203,764
Future Year Cost: 0
Total Project Cost: 894,152
LRTP: Page 3-9

I-95 FROM SLC/MARTIN TO SR-70
4226816 SIS

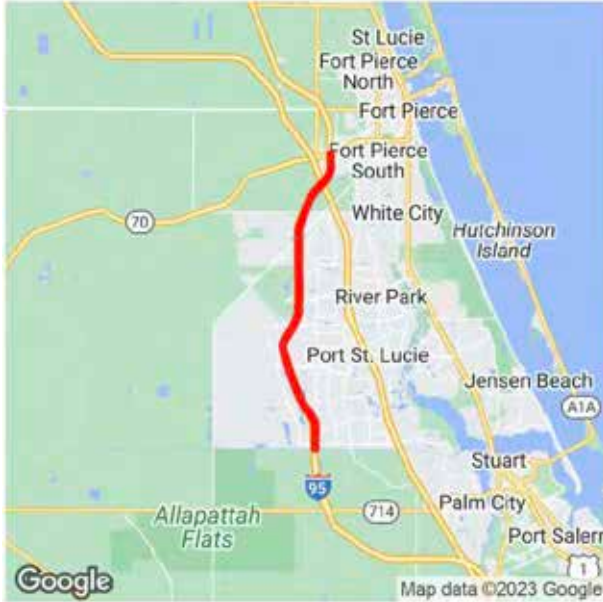

Project Description: PD&E/EMO STUDY
Extra Description: R/W NEEDED
Lead Agency: MANAGED BY FDOT
County: ST. LUCIE
Length: 15.499
Phase Group: P D & E

From: SLC/MARTIN
To: SR-70

Phase	Fund Code	2025	2026	2027	2028	2029	Total
PDE	ACNP	2,110,000	0	0	0	0	2,110,000
		2,110,000					2,110,000

Prior Year Cost: 1,821,960
Future Year Cost: 0
Total Project Cost: 3,931,960
LRTP: Page 8-3

**I-95 ST LUCIE SOUTHBOUND REST AREA
4499611 SIS**

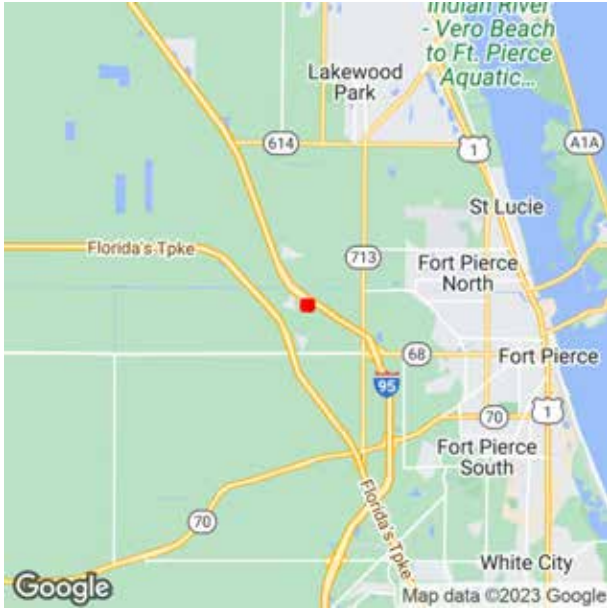

Project Description: REST AREA
Lead Agency: MANAGED BY FDOT
County: ST. LUCIE
Length: 0.54
Phase Group: PRELIMINARY ENGINEERING, CONSTRUCTION

From: ST. LUCIE SB REST AREA
To: ST. LUCIE SB REST AREA

Phase	Fund Code	2025	2026	2027	2028	2029	Total
PE	DDR	0	930,917	0	0	0	930,917
PE	DIH	0	122,833	0	0	0	122,833
PE	DRA	0	2,630,000	1,200,000	0	0	3,830,000
CST	DIH	0	0	0	0	95,439	95,439
CST	DRA	0	0	0	0	28,900,000	28,900,000
		3,683,750	1,200,000			28,995,439	33,879,189

Prior Year Cost: 0
Future Year Cost: 0
Total Project Cost: 33,879,189
LRTP: Page 3-9

JENKINS RD FROM MIDWAY RD TO ORANGE AVE
4463311 Non-SIS

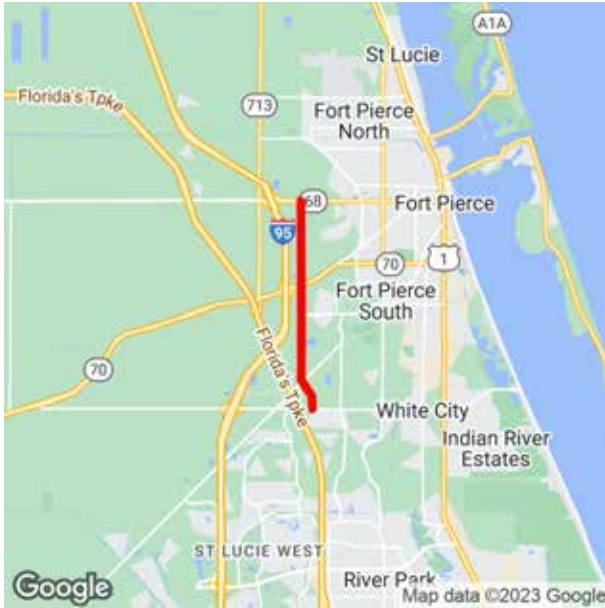

Project Description: PD&E/EMO STUDY
Extra Description: 2024 TPO PRIORITY #6 LFA WITH ST. LUCIE COUNTY R/W IS NEEDED 22-02 WIRE TRANSFER RECEIVED 11/13/23 \$1M ST. LUCIE COUNTY
Lead Agency: MANAGED BY FDOT **From:** MIDWAY RD
County: ST. LUCIE **To:** ORANGE AVE
Length: 5.104
Phase Group: P D & E

Phase	Fund Code	2025	2026	2027	2028	2029	Total
PDE	ACSU	811,624	0	0	0	0	811,624
PDE	SU	828,376	0	0	0	0	828,376
		1,640,000					1,640,000

Prior Year Cost: 5,182,865
Future Year Cost: 0
Total Project Cost: 6,822,865
LRTP: Page 8-3

KESTOR DRIVE FROM SW DARWIN BLVD TO SW BECKER RD
4489981 Non-SIS

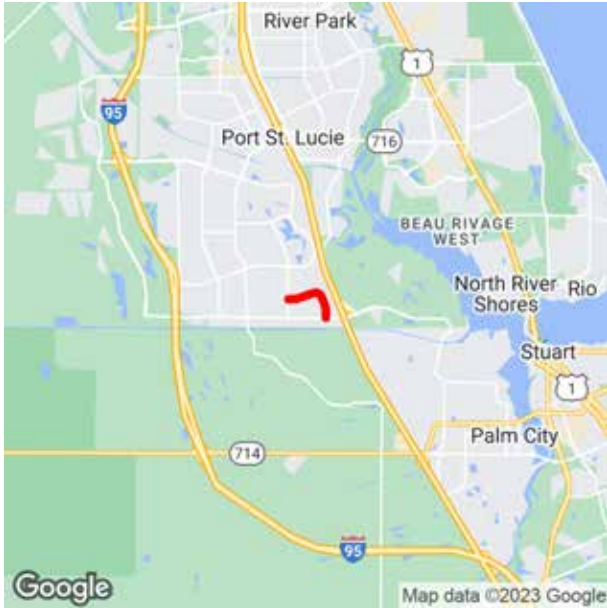

Project Description: SIDEWALK
Extra Description: 2022 TAP PRIORITY #1
Lead Agency: MANAGED BY FDOT
County: ST. LUCIE
Length: 1.389
Phase Group: PRELIMINARY ENGINEERING, CONSTRUCTION

From: SW DARWIN BLVD
To: SW BECKER RD

Phase	Fund Code	2025	2026	2027	2028	2029	Total
CST	LF	187,148	0	0	0	0	187,148
CST	TALT	497,046	0	0	0	0	497,046
CST	TALU	268,446	0	0	0	0	268,446
		952,640					952,640

Prior Year Cost: 5,000
Future Year Cost: 0
Total Project Cost: 957,640
LRTP: Page 8-11

KINGS HIGHWAY FROM NORTH OF I-95 OVERPASS TO SOUTH OF ANGLE RD

4383794 Non-SIS

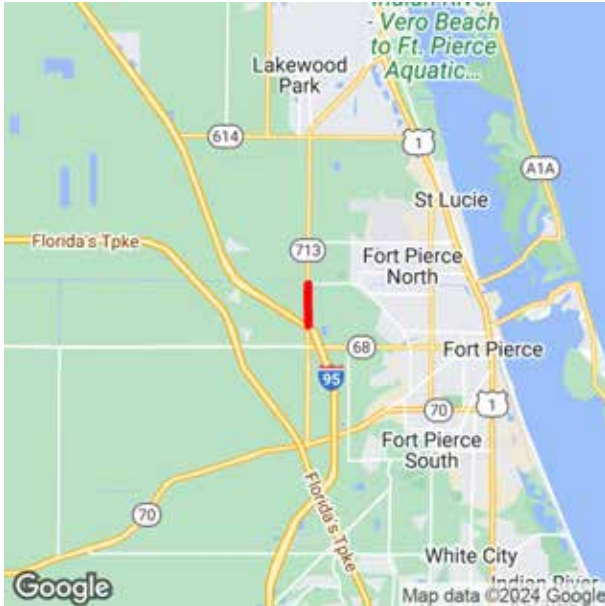

Project Description: ADD LANES & RECONSTRUCT

Extra Description: 2017 TPO PRIORITY #4 WIDENING 2 TO 4 LANES, PD&E UNDER 230256-5, DESIGN & ROW UNDER FM# 438379.1

Lead Agency: MANAGED BY FDOT

From: NORTH OF I-95 OVERPASS

Length: 0.97

To: SOUTH OF ANGLE RD

Phase Group: CONSTRUCTION

Phase	Fund Code	2025	2026	2027	2028	2029	Total
CST	DDR	0	0	11,893,027	1,972,725	0	13,865,752
CST	DIH	0	0	127,248	131,323	0	258,571
CST	DS	0	0	8,525,536	0	0	8,525,536
CST	SA	0	0	2,833,692	0	0	2,833,692
CST	SU	0	0	4,159,002	0	0	4,159,002
				27,538,505	2,104,048		29,642,553

Prior Year Cost: 21,404,740

Future Year Cost: 0

Total Project Cost: 67,751,867

LRTP: Page 8-2

KINGS HWY FROM NORTH OF COMMERCIAL CIRCLE TO NORTH OF ST LUCIE BLVD

4383792 Non-SIS

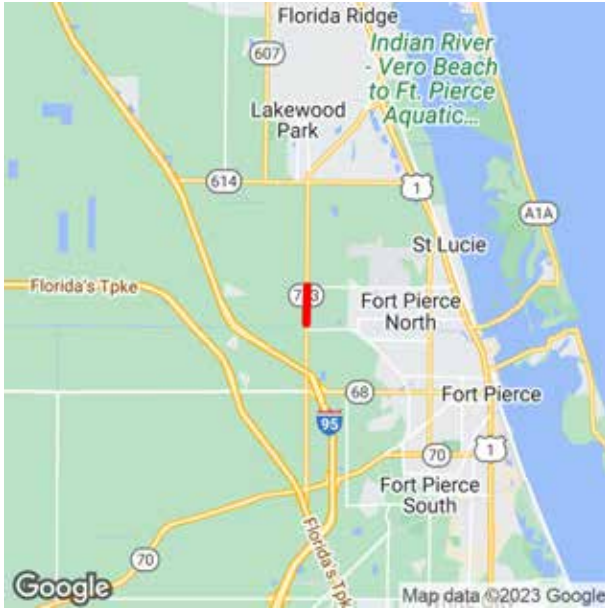

Project Description: ADD LANES & RECONSTRUCT

Extra Description: 2017 TPO PRIORITY #4 WIDENING FROM 2 TO 4 LANES; PD&E UNDER 230256-5 G/W 438379-5

Lead Agency: MANAGED BY FDOT

From: NORTH OF COMMERCIAL CIRCLE

County: ST. LUCIE

To: NORTH OF ST LUCIE BLVD

Length: 1.21

Phase Group: PRELIMINARY ENGINEERING, RIGHT OF WAY, ENVIRONMENTAL

Phase	Fund Code	2025	2026	2027	2028	2029	Total
ROW	CM	0	380,000	0	0	0	380,000
ROW	DDR	0	4,432,414	0	0	0	4,432,414
ROW	SA	2,805,455	0	0	0	0	2,805,455
ROW	SU	1,000,000	0	0	0	0	1,000,000
		3,805,455	4,812,414				8,617,869

Prior Year Cost: 21,404,740

Future Year Cost: 0

Total Project Cost: 67,751,867

LRTP: Page 8-2

KINGS HWY FROM NORTH OF I-95 OVERPASS TO NORTH OF COMMERCIAL CIRCLE

4492911 Non-SIS

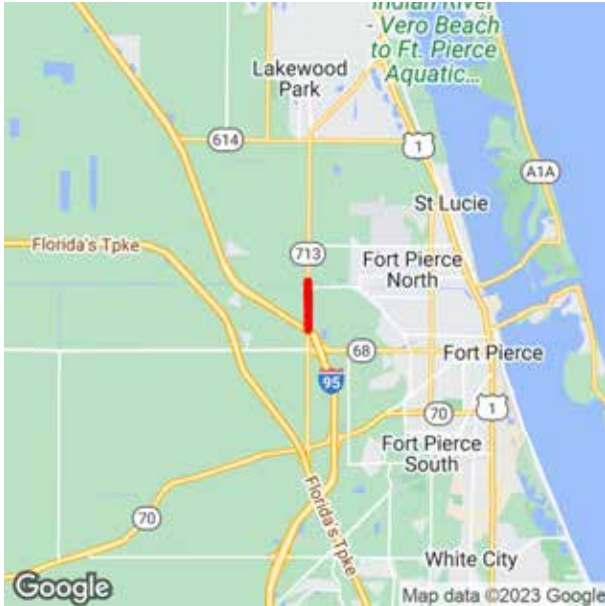

Project Description: LANDSCAPING

Extra Description: STANDALONE LANDSCAPE

Lead Agency: MANAGED BY FDOT

County: ST. LUCIE

Length: 1.4

Phase Group: PRELIMINARY ENGINEERING, CONSTRUCTION

From: NORTH OF I-95 OVERPASS

To: NORTH OF COMMERCIAL CIRCLE

Phase	Fund Code	2025	2026	2027	2028	2029	Total
PE	DDR	0	141,293	0	0	0	141,293
PE	DIH	0	11,303	0	0	0	11,303
CST	DDR	0	0	0	890,792	0	890,792
CST	DIH	0	0	0	33,484	0	33,484
			152,596		924,276		1,076,872

Prior Year Cost: 0

Future Year Cost: 0

Total Project Cost: 1,076,872

LRTP: Page 8-2

KINGS HWY FROM NORTH OF ST LUCIE BLVD TO INDRIIO ROAD
4383793 Non-SIS

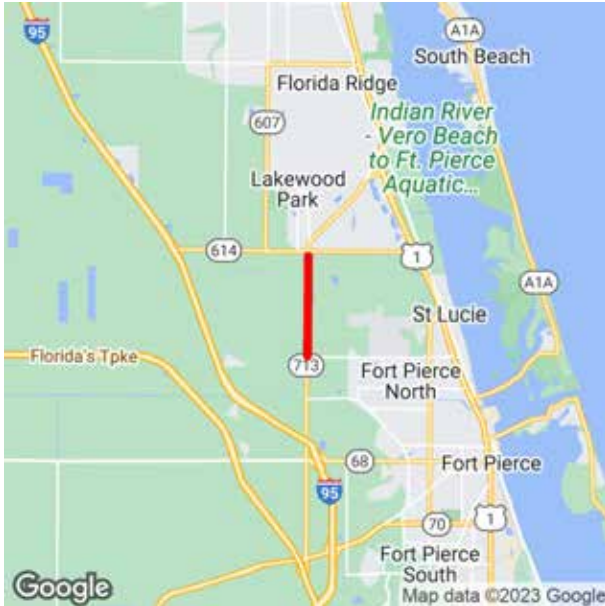

Project Description: ADD LANES & RECONSTRUCT

Extra Description: 2022 TPO PRIORITY #5 WIDENING FROM 2 TO 4 LANES; PD&E UNDER 230256-5 R/W REQUIRED

Lead Agency: MANAGED BY FDOT

From: NORTH OF ST LUCIE BLVD

County: ST. LUCIE

To: INDRIIO ROAD

Length: 2.19

Phase Group: PRELIMINARY ENGINEERING, RIGHT OF WAY, ENVIRONMENTAL

Phase	Fund Code	2025	2026	2027	2028	2029	Total
ROW	DDR	0	0	2,128,890	0	42,750	2,171,640
ROW	DIH	0	0	552,000	0	0	552,000
ROW	DS	0	0	500,000	0	0	500,000
ROW	SU	0	0	0	0	500,000	500,000
				3,180,890		542,750	3,723,640

Prior Year Cost: 21,404,740

Future Year Cost: 0

Total Project Cost: 67,751,867

LRTP: Page 8-2

MARSHFIELD COURT FROM SW DREYFUSS BLVD TO SW HAYWORTH AVE
4529961 Non-SIS

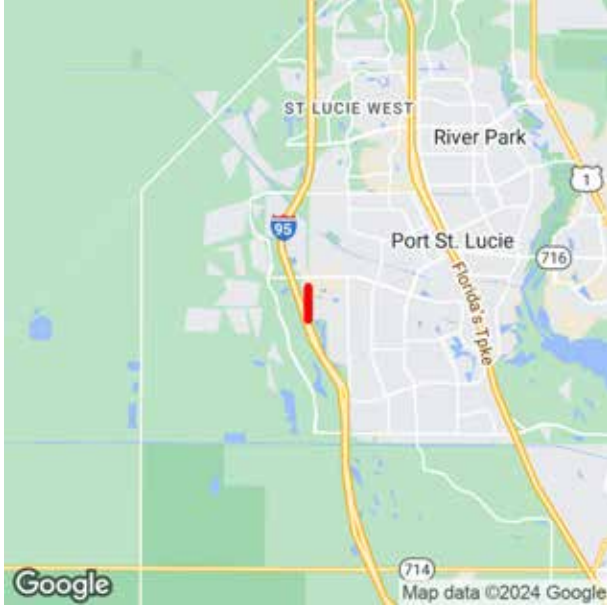

Project Description: BIKE PATH/TRAIL

Lead Agency: MANAGED BY FDOT

Length: 0

Phase Group: PRELIMINARY ENGINEERING, CONSTRUCTION

From: SW DREYFUSS BLVD

To: SW HAYWORTH AVE

Phase	Fund Code	2025	2026	2027	2028	2029	Total
PE	TALT	5,000	0	0	0	0	5,000
CST	LF	0	0	55,000	0	0	55,000
CST	TALT	0	0	1,237,758	0	0	1,237,758
CST	TALU	0	0	376,416	0	0	376,416
		5,000		1,669,174			1,674,174

Prior Year Cost: 0

Future Year Cost: 0

Total Project Cost: 1,674,174

LRTP: Page 3-9

MIDWAY RD FROM GLADES CUT OFF RD TO JUST WEST OF JENKINS RD
2314404 Non-SIS

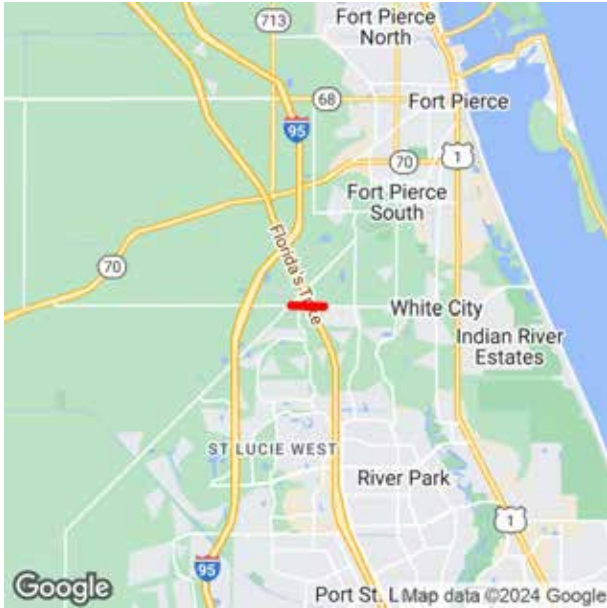

Project Description: ADD LANES & RECONSTRUCT
Extra Description: 2024 TPO PRIORITY #3/4 WIDENING FROM 2 TO 4 LANES. BASED ON PD&E COMPLETED UNDER PROJECT FM 231440-3 DESIGN AND RIGHT OF WAY ON 231440-3
Lead Agency: MANAGED BY FDOT **From:** GLADES CUT OFF RD
Length: 0.725 **To:** JUST WEST OF JENKINS RD
Phase Group: RAILROAD & UTILITIES, CONSTRUCTION

Phase	Fund Code	2025	2026	2027	2028	2029	Total
RRU	FINC	0	100,000	0	0	0	100,000
CST	FINC	0	0	57,818,774	0	0	57,818,774
		100,000	57,818,774				57,918,774

Prior Year Cost: 40,050,052
Future Year Cost: 0
Total Project Cost: 117,904,125
LRTP: Page 8-11

MIDWAY RD FROM GLADES CUT OFF RD TO SELVITZ RD
2314403 Non-SIS

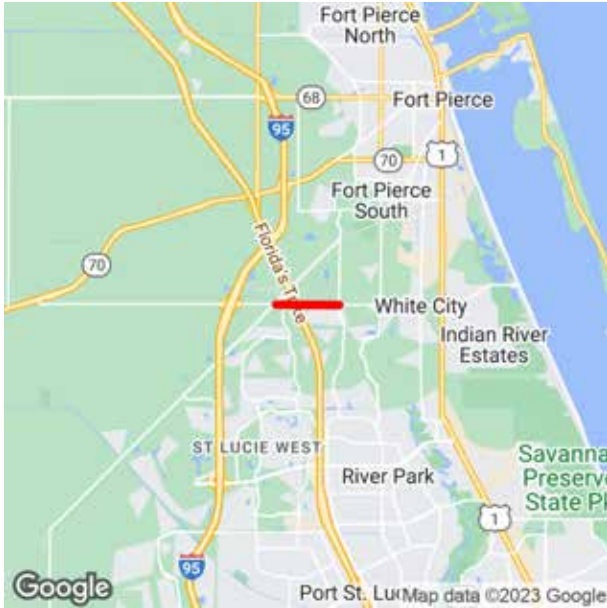

Project Description: ADD LANES & RECONSTRUCT
Extra Description: 2022 TPO PRIORITY #2 WIDENING FROM 2 TO 4 LANES LFA WITH ST LUCIE COUNTY FOR PD&E AND DESIGN CK #09828620 RECD FR ST LUCIE CO BCC FOR 1.65M ON 10/7/14 FOR PD&E THIS IS A CAT2 CHECK RECD 1/25/2017 FROM ST.LUCIE CO \$2,108,000 PH32/37
Lead Agency: MANAGED BY FDOT **From:** GLADES CUT OFF RD
County: ST. LUCIE **To:** SELVITZ RD
Length: 1.577
Phase Group: P D & E, PRELIMINARY ENGINEERING, RIGHT OF WAY, RAILROAD & UTILITIES, ENVIRONMENTAL

Phase	Fund Code	2025	2026	2027	2028	2029	Total
ROW	SA	6,200	80,188	468,500	0	0	554,888
ROW	SU	0	10,018	0	0	0	10,018
		6,200	90,206	468,500			564,906

Prior Year Cost: 40,050,052
Future Year Cost: 0
Total Project Cost: 117,904,125
LRTP: Page 8-2

MIDWAY RD FROM JENKINS RD TO SELVITZ RD
2314405 Non-SIS

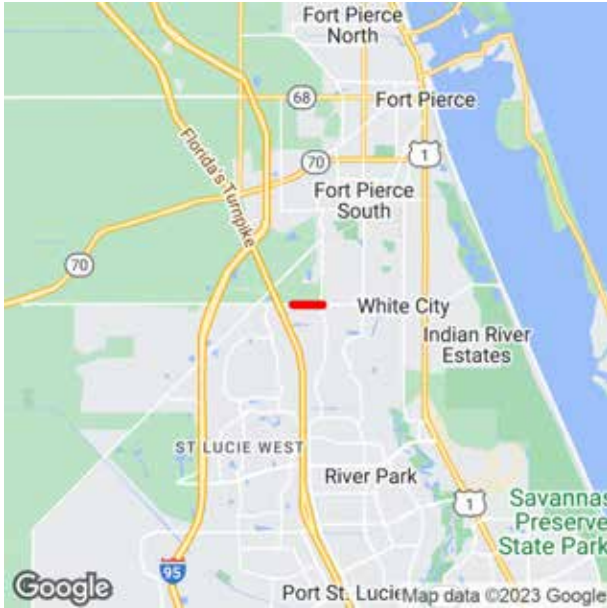

Project Description: ADD LANES & RECONSTRUCT

Extra Description: 2022 TPO PRIORITY #2 WIDENING FROM 2 TO 4 LANES BASED ON PD&E COMPLETED UNDER 231440-3 DESIGN AND RIGHT OF WAY ON 231440-3 56-02: UWHCA WITH CITY OF PORT ST. LUCIE 66-01: UWHCA CEI FOR UTILITIES PROJECT ADVANCEMENT TO FY 24 PER AGREEMENT WST LUCIE COUNTY

Lead Agency: MANAGED BY FDOT

From: JENKINS RD

County: ST. LUCIE

To: SELVITZ RD

Length: 0.785

Phase Group: RAILROAD & UTILITIES, CONSTRUCTION, LOCAL ADVANCE REIMBURSE

Prior Year Cost: 40,050,052
Future Year Cost: 0
Total Project Cost: 117,904,125
LRTP: Page 8-11

Phase	Fund Code	2025	2026	2027	2028	2029	Total
LAR	CIGP	0	7,094,463	0	0	0	7,094,463
LAR	SA	0	3,643,102	0	0	0	3,643,102
LAR	SU	0	3,917,247	0	0	0	3,917,247
LAR	TRIP	0	3,276,644	0	0	0	3,276,644
LAR	TRWR	0	1,438,937	0	0	0	1,438,937
		19,370,393			19,370,393		

MIDWAY RD FROM SELVITZ RD TO US HIGHWAY 1
4534961 Non-SIS

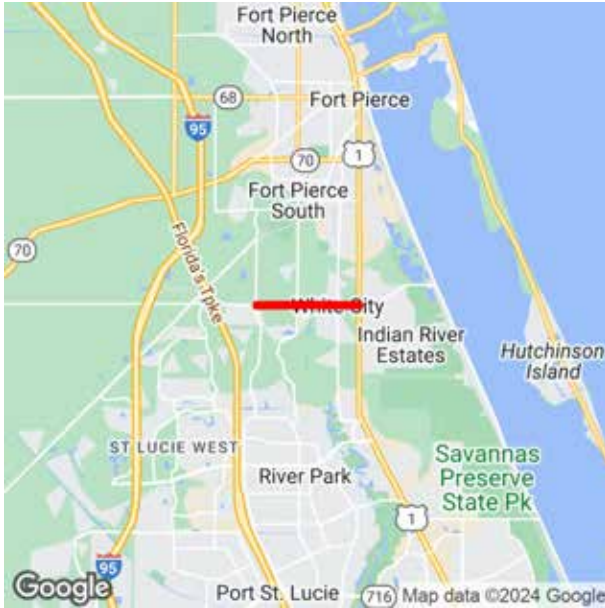

Project Description: ATMS - ARTERIAL TRAFFIC MGMT
Extra Description: 2024 TPO PRIORITY 1 CARBON REDUCTION PROGRAM LAP WITH ST. LUCIE COUNTY. INSTALL FIBER OPTIC CABLE ALONG MIDWAY ROAD & TRAFFIC CAMERAS/VIDEO DETECTORS & ADAPTIVE SIGNAL CONTROL AT THE SIGNALIZED INTERSECTION. INSTALL 2.5 MILES OF FIBER OPTIC CABLE ALONG MIDWAY RD FROM SELVITZ RD TO SR-5/US 1, INTERCONNECT FIVE (5) SIGNALIZED INTERSECTIONS, & UPGRADE
Lead Agency: MANAGED BY FDOT **From:** SELVITZ RD
Length: 2.524 **To:** US HIGHWAY 1
Phase Group: PRELIMINARY ENGINEERING, CONSTRUCTION

Phase	Fund Code	2025	2026	2027	2028	2029	Total
CST	CARU	0	349,978	269,448	0	0	619,426
CST	LF	0	143,190	0	0	0	143,190
			493,168	269,448			762,616

Prior Year Cost: 5,000
Future Year Cost: 0
Total Project Cost: 767,616
LRTP: Page 3-9

NEBRASKA AVE FROM SOUTH LAWNWOOD CIRCLE TO SOUTH 13TH ST
4534921 Non-SIS

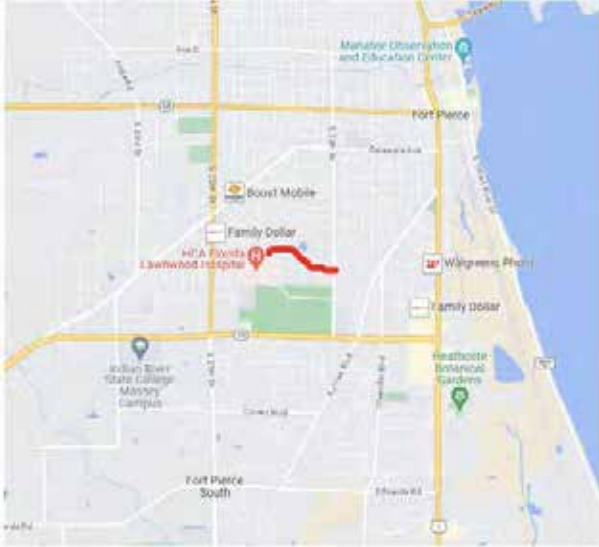

Project Description: SIDEWALK

Extra Description: 2024 TPO CARBON REDUCTION PRIORITY #5 SIDEWALKS, 6 FEET IN WIDTH, 1 MILE IN LENGTH, ON BOTH SIDES OF STREET

Lead Agency: MANAGED BY FDOT

From: SOUTH LAWNWOOD CIRCLE

County: ST. LUCIE

To: SOUTH 13TH ST

Length: 0.49

Phase Group: PRELIMINARY ENGINEERING, CONSTRUCTION

Phase	Fund Code	2025	2026	2027	2028	2029	Total
CST	LF	0	134,800	0	0	0	134,800
CST	TALU	0	217,101	100,000	0	0	317,101
			351,901	100,000			451,901

Prior Year Cost: 5,000

Future Year Cost: 0

Total Project Cost: 456,901

LRTP: Page 3-9

OLEANDER AVE FROM SOUTH MARKET AVE TO EDWARDS RD
4480661 Non-SIS

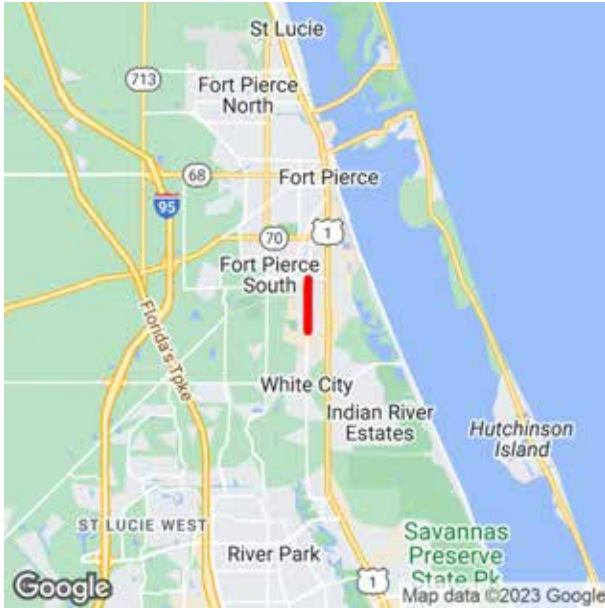

Project Description: SIDEWALK
Extra Description: FOREST GROVE MIDDLE SCHOOL SAFE ROUTES TO SCHOOL; LAP WITH ST LUCIE COUNTY
Lead Agency: MANAGED BY FDOT **From:** SOUTH MARKET AVE
County: ST. LUCIE **To:** EDWARDS RD
Length: 1.326
Phase Group: PRELIMINARY ENGINEERING

Phase	Fund Code	2025	2026	2027	2028	2029	Total
PE	SR2T	5,000	0	0	0	0	5,000
		5,000					5,000

Prior Year Cost: 0
Future Year Cost: 0
Total Project Cost: 5,000
LRTP: Page 3-9

ORANGE AVE FROM KINGS HWY TO EAST OF I-95 SB RAMP
4461681 SIS

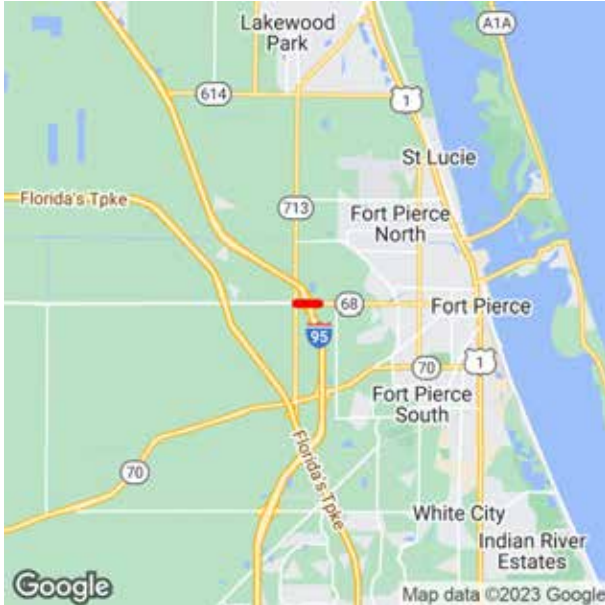

Prior Year Cost: 805,014
Future Year Cost: 0
Total Project Cost: 8,825,234
LRTP: Page 8-3

Project Description: INTERCHANGE - ADD LANES

Extra Description: ADD EB RIGHT TURN LANE FROM ORANGE AVE/SR-68 TO I-95 SB ON-RAMP & ADD WB RIGHT-TURN LANE FR ORANGE AVE/SR-68 TO NB KINGS HWY/SR-713 NB & WB PROTECTED RIGHT TURN PHASES TO BE ADDED AT INTERSECTION OF ORANGE AVE/SR-68 AND KINGS HWY/ SR-713 EB TO SB ON-RAMP ENTRANCE TO BE RELOCATED TO THE EXISTING SIGNALIZED INTERSECTION FOR THE WB TO SB (SEE WP45)

Lead Agency: MANAGED BY FDOT

From: KINGS HWY

County: ST. LUCIE

To: EAST OF I-95 SB RAMP

Length: 0.646

Phase Group: P D & E, PRELIMINARY ENGINEERING, RIGHT OF WAY, CONSTRUCTION, ENVIRONMENTAL

Phase	Fund Code	2025	2026	2027	2028	2029	Total
PE	ACFP	24,423	0	0	0	0	24,423
ROW	ACFP	382,386	0	0	0	0	382,386
ROW	DDR	56,000	195,368	0	0	0	251,368
CST	ACNP	0	0	0	0	7,362,043	7,362,043
		462,809	195,368			7,362,043	8,020,220

ORANGE AVE FROM KINGS HWY TO US HIGHWAY 1
4496961 Non-SIS

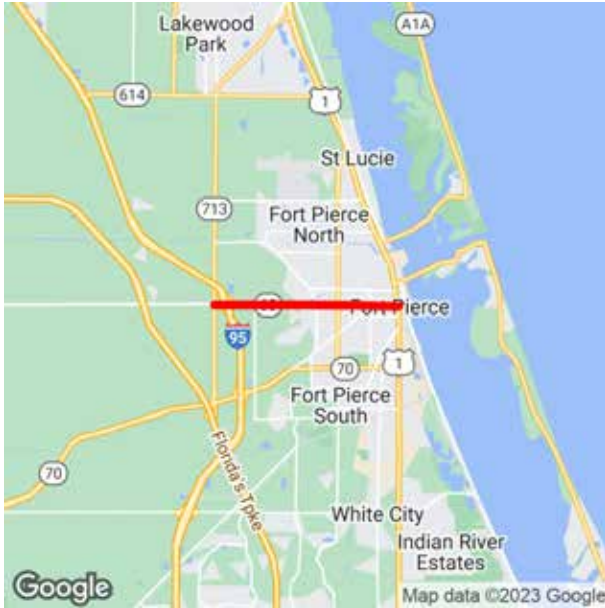

Project Description: ATMS - ARTERIAL TRAFFIC MGMT
Extra Description: 2022 TPO CMP PRIORITY #3 INCLUDES SOUTH 7TH STREET FROM SR-68/ORANGE AVE TO AVE A INSTALL FIBER OPTIC CABLE, TRAFFIC CAMERAS/VIDEO DETECTORS AND ADAPTIVE SIGNAL CONTROL AT SIGNALIZED INTERSECTIONS NO R/W NEEDED
Lead Agency: MANAGED BY FDOT **From:** KINGS HWY
County: ST. LUCIE **To:** US HIGHWAY 1
Length: 4.187
Phase Group: PRELIMINARY ENGINEERING

Phase	Fund Code	2025	2026	2027	2028	2029	Total
PE	CARB	0	0	320,627	0	0	320,627
PE	DIH	0	0	25,650	0	0	25,650
				346,277			346,277

Prior Year Cost: 0
Future Year Cost: 0
Total Project Cost: 346,277
LRTP: Page 8-11

ORANGE AVE FROM LAMONT RD TO N 32ND ST
4484481 Non-SIS

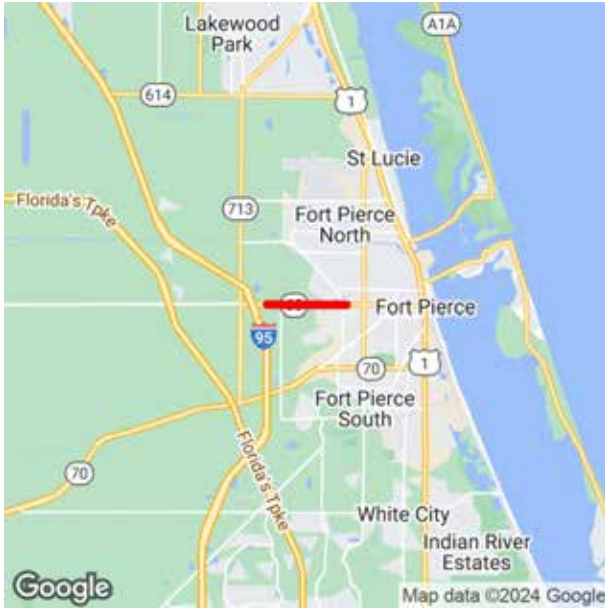

Project Description: RESURFACING

Lead Agency: MANAGED BY FDOT

Length: 1.948

Phase Group: PRELIMINARY ENGINEERING, CONSTRUCTION

From: LAMONT RD

To: N 32ND ST

Phase	Fund Code	2025	2026	2027	2028	2029	Total
PE	DDR	527,215	0	0	0	0	527,215
PE	DIH	24,896	0	0	0	0	24,896
CST	DDR	0	0	0	3,303,884	0	3,303,884
CST	DIH	0	0	0	132,155	0	132,155
CST	DS	0	0	0	446,024	0	446,024
		552,111			3,882,063		4,434,174

Prior Year Cost: 0

Future Year Cost: 0

Total Project Cost: 4,434,174

LRTP: Page 3-9

**OUTFALL FOR VIRGINIA AVE
4417151 SIS**

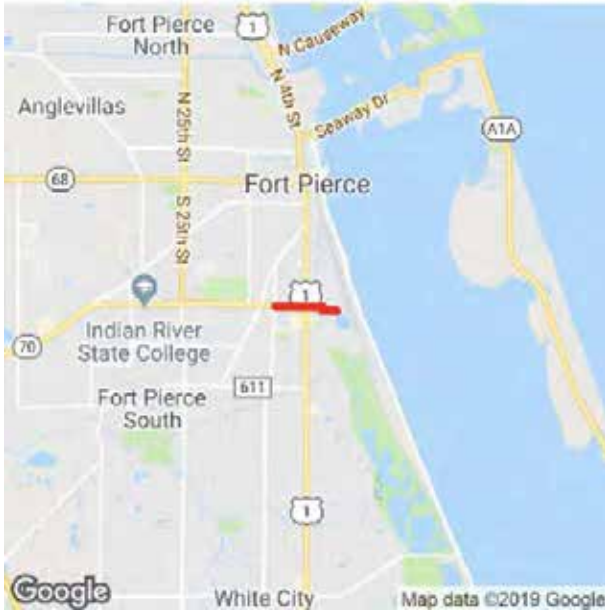

Project Description: DRAINAGE IMPROVEMENTS

Extra Description: OUTFALL WILL BE ROUTED FROM CANAL 7D (CITY CANAL EAST OF OLEANDER BLVD) ALONG VIRGINIA AVE, SOUTH ON SR-5/US HIGHWAY 1 AND THEN EAST THROUGH INDIAN HILLS DR TO ULTIMATELY OUTFALL INTO THE SAND MINE LAKE G/W 441714-1(LEAD)

Lead Agency: MANAGED BY FDOT

From: OLEANDER BLVD

County: ST. LUCIE

To: INDIAN HILLS DR

Length: 0.177

Phase Group: PRELIMINARY ENGINEERING, RIGHT OF WAY, CONSTRUCTION, ENVIRONMENTAL

Phase	Fund Code	2025	2026	2027	2028	2029	Total
CST	ACPR	0	0	3,580,198	0	0	3,580,198
CST	DIH	0	0	107,305	30,653	0	137,958
CST	DS	0	0	558,756	0	0	558,756
CST	SA	0	0	5,665,458	0	0	5,665,458
				9,911,717	30,653		9,942,370

Prior Year Cost: 1,026,664

Future Year Cost: 0

Total Project Cost: 10,969,034

LRTP: Page 3-9

PORT OF FT. PIERCE SUN TRAIL CONNECTOR
4473991 Non-SIS

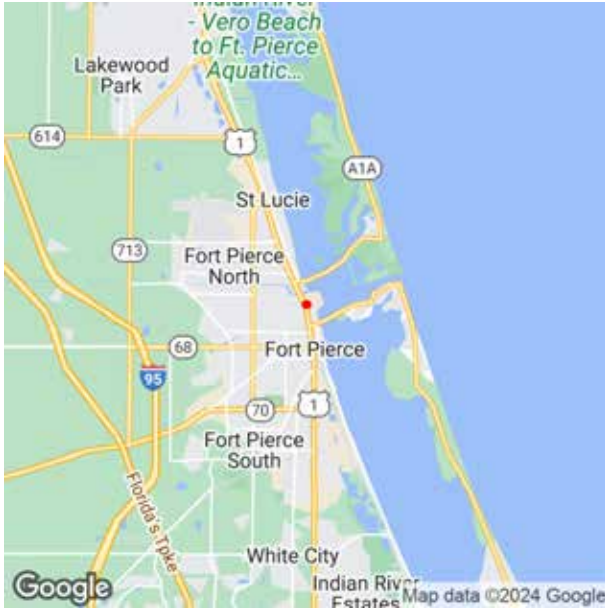

Project Description: BIKE PATH/TRAIL

Extra Description: A SEGMENT OF THE HISTORIC FT. PIERCE DOWNTOWN PROJECT FROM DIXIE HIGHWAY TO 2ND STREET AT FISHERMANS WHARF

Lead Agency: RESPONSIBLE AGENCY NOT AVAILABLE

From: PORT OF FT. PIERCE

To: PORT OF FT. PIERCE

Length: 0

Phase Group: PLANNING, PRELIMINARY ENGINEERING

Phase	Fund Code	2025	2026	2027	2028	2029	Total
PE	TLWR	1,100,000	0	0	0	0	1,100,000
		1,100,000					1,100,000

Prior Year Cost: 250,000

Future Year Cost: 0

Total Project Cost: 1,350,000

LRTP: Page 3-9

PORT ST. LUCIE BLVD FROM BECKER RD TO PAAR DRIVE
4317523 Non-SIS

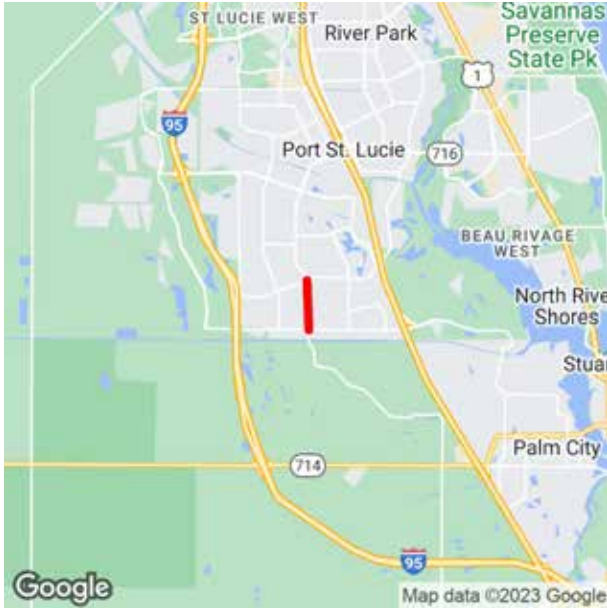

Prior Year Cost: 3,097,063
Future Year Cost: 0
Total Project Cost: 63,964,544
LRTP: Page 8-2

Project Description: ADD LANES & RECONSTRUCT
Extra Description: 2022 TPO PRIORITY #3. WIDENING FROM 2 TO 4 LANES.
Lead Agency: MANAGED BY FDOT **From:** BECKER RD
County: ST. LUCIE **To:** PAAR DRIVE
Length: 1.119
Phase Group: PRELIMINARY ENGINEERING, RIGHT OF WAY, RAILROAD & UTILITIES, CONSTRUCTION, ENVIRONMENTAL, LOCAL ADVANCE REIMBURSE

Phase	Fund Code	2025	2026	2027	2028	2029	Total
ROW	SU	0	272,744	14,984	0	0	287,728
RRU	SU	0	0	100,000	0	0	100,000
CST	LFR	0	18,594,737	0	0	0	18,594,737
CST	SU	0	1,315,912	0	0	0	1,315,912
CST	TRIP	0	1,158,318	0	0	0	1,158,318
LAR	ACPR	0	0	0	2,317,855	0	2,317,855
LAR	CARU	0	0	0	78,214	0	78,214
LAR	CM	0	0	0	718,692	0	718,692
LAR	SA	0	0	0	7,178,276	0	7,178,276
LAR	SU	0	0	0	4,431,700	0	4,431,700
LAR	TRIP	0	0	0	1,403,873	0	1,403,873
LAR	TRWR	0	0	0	2,466,127	0	2,466,127
			21,341,711	114,984	18,594,737		40,051,432

PORT ST. LUCIE BLVD FROM SOUTH OF PAAR DR TO SOUTH OF ALCANTARRA BLVD
4317525 Non-SIS

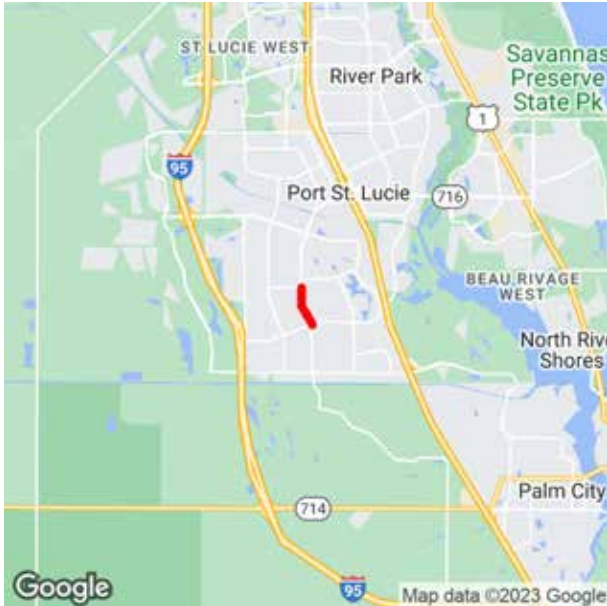

Prior Year Cost: 3,097,063
Future Year Cost: 0
Total Project Cost: 63,964,544
LRTP: Page 8-2

Project Description: ADD LANES & RECONSTRUCT

Extra Description: 2020 TPO PRIORITY #2; WIDENING FROM 2 TO 4 LANES. DESIGN AND RIGHT OF WAY ON 431752-2 DENING FROM 2 TO 4 LANES LFA WITH CITY OF PORT ST. LUCIE. 56-01 LF UWHCA 62-03 LF FOR CEI FOR UWHCA CITY OF PORT ST. LUCIE --NEW SEQUENCE 52-02 WAS CREATED TO PULL FROM APPROPRIATE BUDGET CATEGORY (NON-PROGRAM 87)

Lead Agency: MANAGED BY FDOT

From: SOUTH OF PAAR DR

County: ST. LUCIE

To: SOUTH OF ALCANTARRA BLVD

Length: 1.076

Phase Group: RAILROAD & UTILITIES, CONSTRUCTION

Phase	Fund Code	2025	2026	2027	2028	2029	Total
RRU	LF	1,807,473	0	0	0	0	1,807,473
CST	ACSU	960,459	0	0	0	0	960,459
CST	CD23	2,000,000	0	0	0	0	2,000,000
CST	CIGP	5,548,619	0	0	0	0	5,548,619
CST	LFP	3,548,619	0	0	0	0	3,548,619
CST	SU	3,260,440	0	0	0	0	3,260,440
CST	TRIP	2,214,712	0	0	0	0	2,214,712
CST	TRWR	1,475,727	0	0	0	0	1,475,727
		20,816,049					20,816,049

**PORT ST. LUCIE BLVD FROM WEST OF SE SHELTER DRIVE TO US HIGHWAY 1
4463761 Non-SIS**

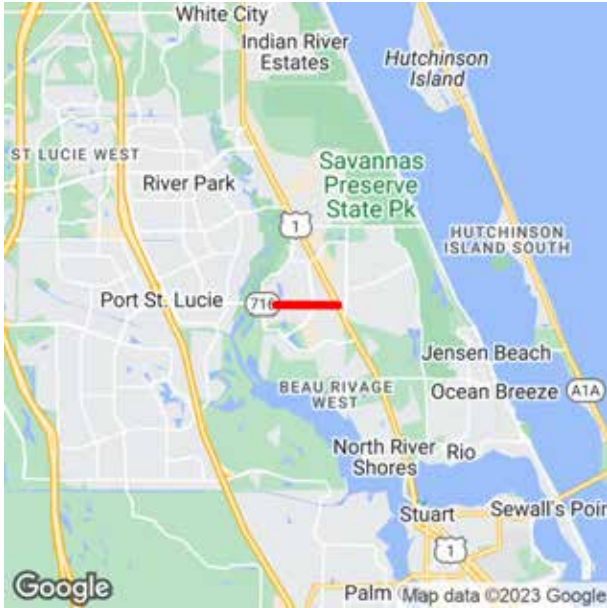

Project Description: RESURFACING

Extra Description: G/W 447652-1 52-02-UWHCA WITH THE CITY OF PORT ST. LUCIE FOR MINOR ADJUSTMENTS

Lead Agency: MANAGED BY FDOT

From: WEST OF SE SHELTER DRIVE

County: ST. LUCIE

To: US HIGHWAY 1

Length: 1.555

Phase Group: PRELIMINARY ENGINEERING, CONSTRUCTION

Phase	Fund Code	2025	2026	2027	2028	2029	Total
CST	ACNR	799,951	0	0	0	0	799,951
CST	DDR	2,596,163	0	0	0	0	2,596,163
CST	DIH	0	114,396	0	0	0	114,396
CST	DS	822,337	0	0	0	0	822,337
CST	LF	1,344	0	0	0	0	1,344
		4,219,795	114,396				4,334,191

Prior Year Cost: 469,892

Future Year Cost: 0

Total Project Cost: 4,804,083

LRTP: Page 3-9

**SHOREWINDS DR/A1A
4498281 Non-SIS**

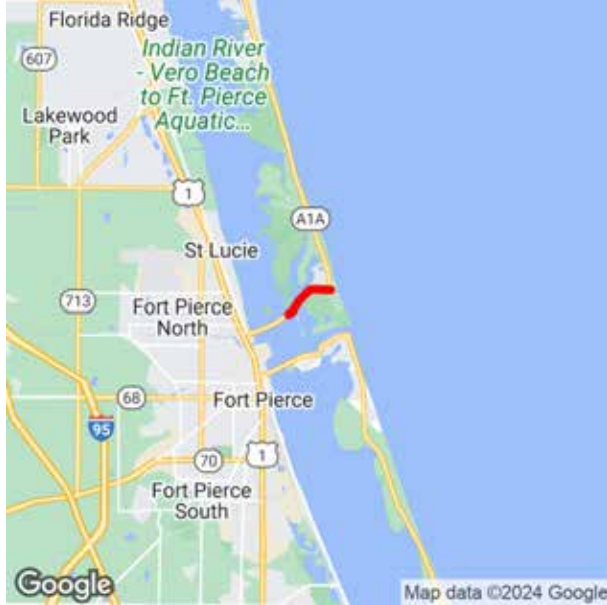

Project Description: RESURFACING

Lead Agency: MANAGED BY FDOT

Length: 1.301

Phase Group: PRELIMINARY ENGINEERING, CONSTRUCTION

From: 0.2 MILES W OF BR 940046

To: ATLANTIC BEACH BLVD

Phase	Fund Code	2025	2026	2027	2028	2029	Total
CST	DDR	0	0	0	3,393,110	0	3,393,110
CST	DIH	0	0	0	92,030	0	92,030
					3,485,140		3,485,140

Prior Year Cost: 678,555

Future Year Cost: 0

Total Project Cost: 4,163,695

LRTP: Page 3-9

**SR-70/OKEECHOBEE ROAD FROM IDEAL HOLDING RD TO W OF KINGS HWY
4476531 SIS**

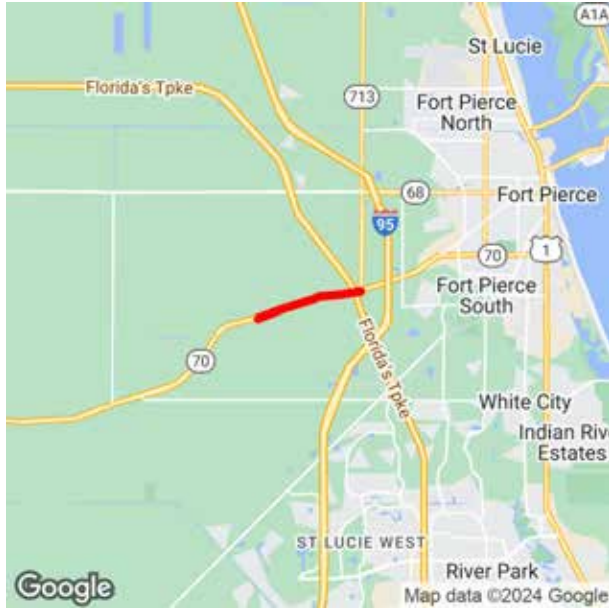

Project Description: RESURFACING

Lead Agency: MANAGED BY FDOT

Length: 7.984

Phase Group: PRELIMINARY ENGINEERING, CONSTRUCTION

From: IDEAL HOLDING RD

To: W OF KINGS HWY

Phase	Fund Code	2025	2026	2027	2028	2029	Total
CST	DDR	1,175,538	825,049	0	0	0	2,000,587
CST	DDR	16,796,284	0	0	0	0	16,796,284
CST	DIH	65,115	70,275	0	0	0	135,390
CST	DS	3,351,995	0	0	0	0	3,351,995
CST	SA	2,968,488	0	0	0	0	2,968,488
		24,357,420	895,324				25,252,744

Prior Year Cost: 1,448,966

Future Year Cost: 0

Total Project Cost: 45,074,338

LRTP: Page 3-9

SR-70/OKEECHOBEE ROAD FROM MEDIAN CROSSING AT BMP 6.351 TO IDEAL HOLDING RD
4476532 SIS



Project Description: RESURFACING

Lead Agency: MANAGED BY FDOT

County: ST. LUCIE

Length: 6.149

Phase Group: PRELIMINARY ENGINEERING, CONSTRUCTION

From: MEDIAN CROSSING AT BMP 6.351

To: IDEAL HOLDING RD

Phase	Fund Code	2025	2026	2027	2028	2029	Total
PE	DDR	1,657,098	0	0	0	0	1,657,098
PE	DIH	108,349	0	0	0	0	108,349
CST	ACNR	0	0	0	8,665,014	0	8,665,014
CST	DDR	0	0	0	7,798,382	0	7,798,382
CST	DIH	0	0	0	143,785	0	143,785
		1,765,447			16,607,181		18,372,628

Prior Year Cost: 1,448,966

Future Year Cost: 0

Total Project Cost: 45,074,338

LRTP: Page 3-9

ST. JAMES DRIVE FROM NE LAZY RIVER PARKWAY TO NE ROYCE AVE
4534911 Non-SIS

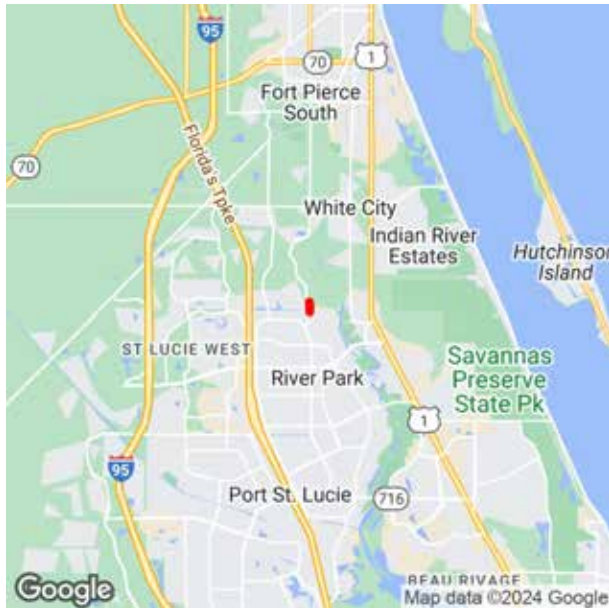

Project Description: SIDEWALK

Extra Description: 2024 TPO CARBON REDUCTION PRIORITY #4 SIDEWALK, 6-8 FEET IN WIDTH, 0.25 MILE IN LENGTH

Lead Agency: MANAGED BY FDOT

From: NE LAZY RIVER PARKWAY

Length: 0.245

To: NE ROYCE AVE

Phase Group: PRELIMINARY ENGINEERING, CONSTRUCTION

Phase	Fund Code	2025	2026	2027	2028	2029	Total
PE	TALL	5,000	0	0	0	0	5,000
CST	CARU	0	0	289,382	0	0	289,382
CST	LF	0	0	80,013	0	0	80,013
		5,000		369,395			374,395

Prior Year Cost: 0

Future Year Cost: 0

Total Project Cost: 374,395

LRTP: Page 3-9

ST. LUCIE BLVD FROM EAST OF N 25 ST TO WEST OF US HIGHWAY 1

4484491 Non-SIS

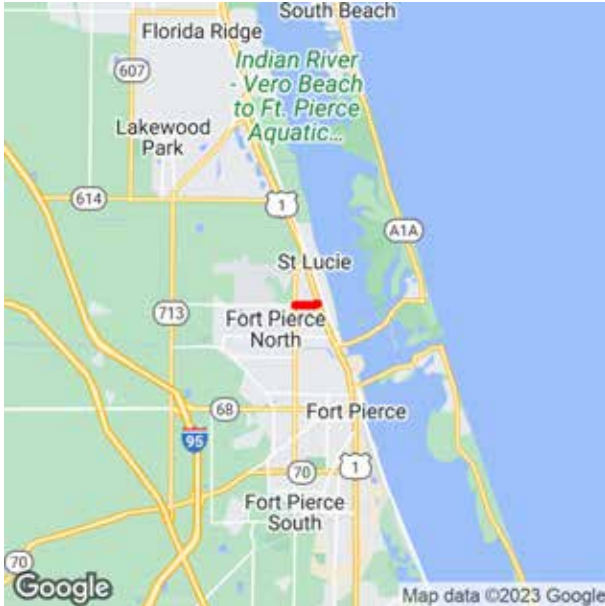

Project Description: RESURFACING

Extra Description: G/W 448450.1(LEAD)

Lead Agency: MANAGED BY FDOT

County: ST. LUCIE

Length: 0.523

Phase Group: PRELIMINARY ENGINEERING, CONSTRUCTION

From: EAST OF N 25 ST

To: WEST OF US HIGHWAY 1

Phase	Fund Code	2025	2026	2027	2028	2029	Total
CST	DDR	0	0	0	107,780	0	107,780
CST	DIH	0	0	0	35,054	0	35,054
CST	DS	0	0	0	856,608	0	856,608
					999,442		999,442

Prior Year Cost: 270,906

Future Year Cost: 0

Total Project Cost: 1,270,348

LRTP: Page 3-9

TURNPIKE FEEDER RD FROM INDRIIO RD TO US-1
4510811 Non-SIS

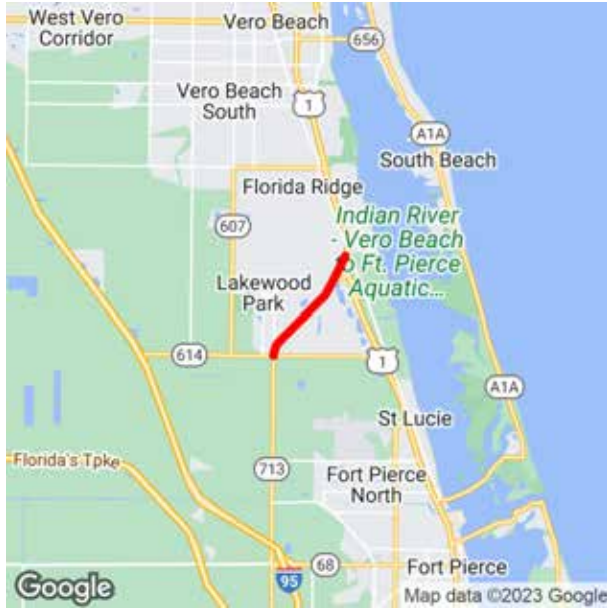

Project Description: LIGHTING

Extra Description: B/C RATIO= 2.5 NPV \$2,646,838 SHSP EMPHASIS AREA(S): INTERSECTION & VULNERABLE ROAD USER CRASHES SEGMENT 1 (FROM INDRIIO ROAD TO STA 136+80, 540 FT NORTH OF INDRIIO ROAD):PROPOSED LIGHTING CONSISTS OF LED LIGHT FIXTURES ON THE WEST SIDE AND EAST SIDE OF SR 713 SEGMENT 2 (FROM STA 136+80 TO S OF PALOMAR PKWY):PROPOSED...SEE WP45

Lead Agency: MANAGED BY FDOT

From: INDRIIO RD

County: ST. LUCIE

To: US-1

Length: 2.741

Phase Group: PRELIMINARY ENGINEERING, CONSTRUCTION

Phase	Fund Code	2025	2026	2027	2028	2029	Total
CST	ACSS	0	0	2,238,159	0	0	2,238,159
CST	CARB	0	0	2,186,000	0	0	2,186,000
CST	SA	0	0	70,902	0	0	70,902
				4,495,061			4,495,061

Prior Year Cost: 283,467

Future Year Cost: 0

Total Project Cost: 4,778,528

LRTP: Page 3-9

US HIGHWAY 1 FROM EDWARDS RD TO TENNESSEE AVE
4417141 SIS

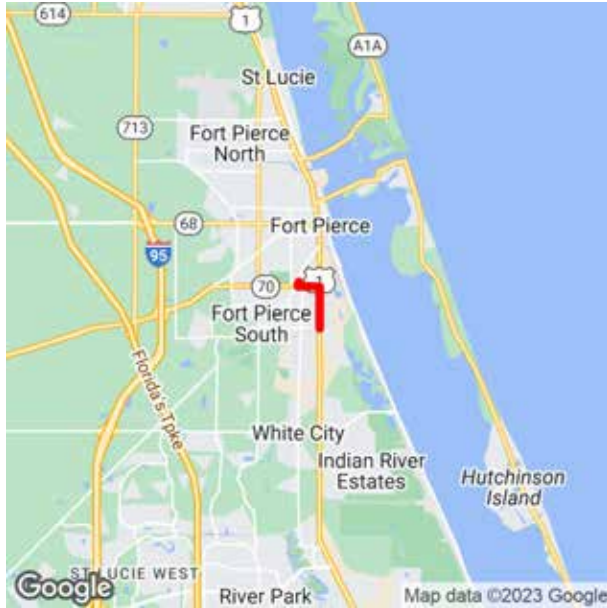

Project Description: DRAINAGE IMPROVEMENTS

Extra Description: DRAINAGE/STORM WATER UPGRADES RESURFACING ON PHASE 52-02 INCLUDING: INTERSECTION LIGHTING RETROFIT. UPGRADE PEDESTRIAN SIGNALS TO COUNTDOWN AT THE FOLLOWING INTERSECTIONS: EDWARDS ROAD, EMIL AVE. GARDENIA AVE. AND VIRGINIA AVE

Lead Agency: MANAGED BY FDOT

From: EDWARDS RD

County: ST. LUCIE

To: TENNESSEE AVE

Length: 1.124

Phase Group: PRELIMINARY ENGINEERING, RIGHT OF WAY, RAILROAD & UTILITIES, CONSTRUCTION, ENVIRONMENTAL

Prior Year Cost: 1,836,965
Future Year Cost: 0
Total Project Cost: 17,702,381
LRTP: Page 3-9

Phase	Fund Code	2025	2026	2027	2028	2029	Total
CST	ACNR	0	0	1,701,218	0	0	1,701,218
CST	ACPR	0	0	10,644,394	0	0	10,644,394
CST	DDR	0	0	1,453,212	0	0	1,453,212
CST	DIH	0	0	57,106	0	0	57,106
CST	SA	0	0	2,009,486	0	0	2,009,486
				15,865,416			15,865,416

US HIGHWAY 1 FROM JUANITA AVE TO NORTH OF KINGS HWY
4484501 Non-SIS

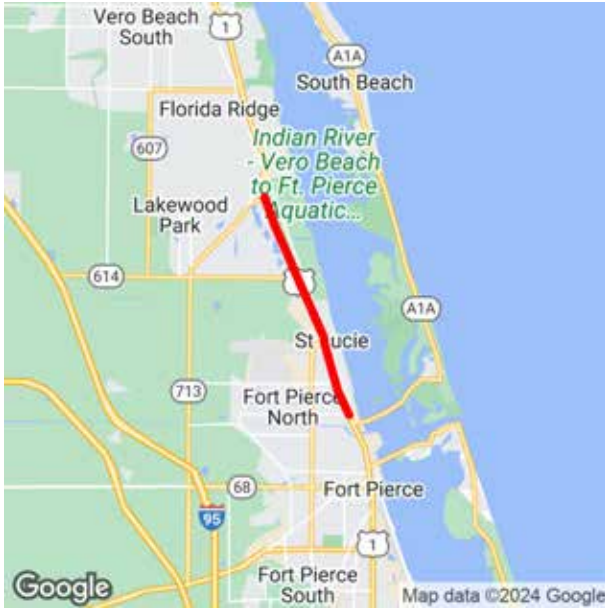

Project Description: RESURFACING

Extra Description: G/W 448449-1

Lead Agency: MANAGED BY FDOT

Length: 5.836

Phase Group: PRELIMINARY ENGINEERING, CONSTRUCTION

From: JUANITA AVE

To: NORTH OF KINGS HWY

Phase	Fund Code	2025	2026	2027	2028	2029	Total
CST	DDR	0	0	0	10,181,688	0	10,181,688
CST	DIH	0	0	0	109,051	0	109,051
CST	DS	0	0	0	7,688,985	0	7,688,985
CST	SA	0	0	0	4,891,411	0	4,891,411
					22,871,135		22,871,135

Prior Year Cost: 2,247,207

Future Year Cost: 0

Total Project Cost: 25,118,342

LRTP: Page 3-9

US HIGHWAY 1 FROM MARTIN/ST LUCIE COUNTY LINE TO SE PORT ST LUCIE BLVD

4476521 Non-SIS

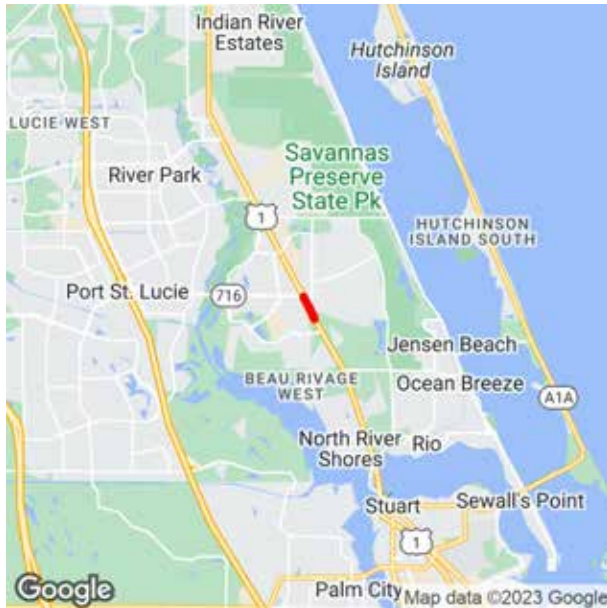

Project Description: RESURFACING

Extra Description: G/W 446376-1 (LEAD)

Lead Agency: MANAGED BY FDOT

County: ST. LUCIE

Length: 0.669

Phase Group: PRELIMINARY ENGINEERING, CONSTRUCTION

From: MARTIN/ST LUCIE COUNTY LINE

To: SE PORT ST LUCIE BLVD

Phase	Fund Code	2025	2026	2027	2028	2029	Total
CST	DIH	91,455	0	0	0	0	91,455
CST	DS	3,345,856	0	0	0	0	3,345,856
CST	LF	452	0	0	0	0	452
		3,437,763					3,437,763

Prior Year Cost: 470,160

Future Year Cost: 0

Total Project Cost: 3,907,923

LRTP: Page 3-9

US HIGHWAY 1 FROM MIDWAY RD TO SOUTH OF EDWARDS RD
4510801 Non-SIS

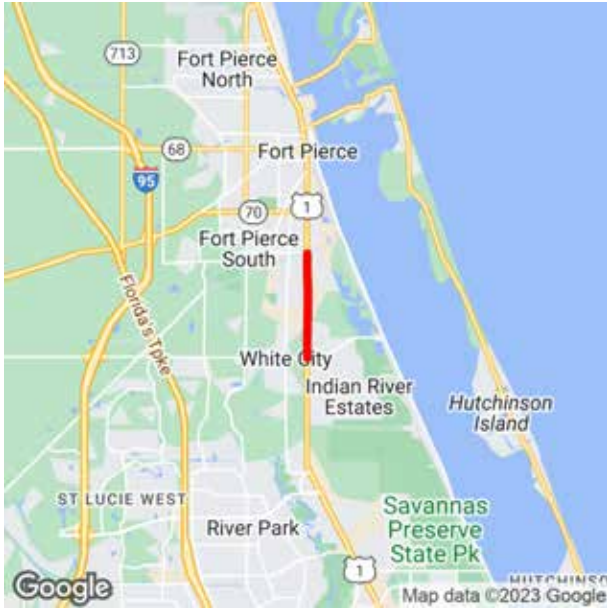

Project Description: LIGHTING

Extra Description: B/C RATIO = 2.8 NPV \$4,153,539 SHSP EMPHASIS AREA(S): INTERSECTION & VULNERABLE ROAD USER CRASHES RETROFIT TWO (2) DECORATIVE LIGHT POLES ON THE WEST SIDE OF W. MIDWAY RD; ONLY STREET LIGHTING LUMINAIRES. RETROFIT 38 EXISTING LUMINARIES ATTACHED TO EXISTING UTILITIES POLES. PROPOSED 119 LUMINARIES BRACKET ON EXISTING ...SEE WP45

Lead Agency: MANAGED BY FDOT

From: MIDWAY RD

County: ST. LUCIE

To: SOUTH OF EDWARDS RD

Length: 2.513

Phase Group: PRELIMINARY ENGINEERING, RAILROAD & UTILITIES

Phase	Fund Code	2025	2026	2027	2028	2029	Total
RRU	ACSS	0	1,043,395	0	0	0	1,043,395
			1,043,395				1,043,395

Prior Year Cost: 270,849

Future Year Cost: 0

Total Project Cost: 1,314,244

LRTP: Page 3-9

VOLUCIA DRIVE FROM EAST TORINO PARKWAY TO WEST BLANTON BLVD
4508611 Non-SIS

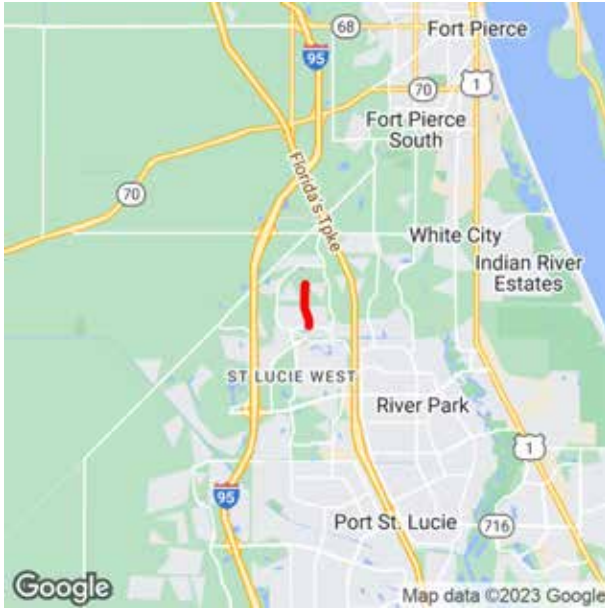

Project Description: SIDEWALK
Extra Description: 2023 TA PRIORITY #1 LAP W/ CITY OF PORT ST. LUCIE
Lead Agency: MANAGED BY FDOT **From:** EAST TORINO PARKWAY
County: ST. LUCIE **To:** WEST BLANTON BLVD
Length: 1.003
Phase Group: PRELIMINARY ENGINEERING, CONSTRUCTION

Phase	Fund Code	2025	2026	2027	2028	2029	Total
CST	LF	0	189,683	0	0	0	189,683
CST	TALT	0	183,882	0	0	0	183,882
CST	TALU	0	593,192	0	0	0	593,192
			966,757				966,757

Prior Year Cost: 5,000
Future Year Cost: 0
Total Project Cost: 971,757
LRTP: Page 3-9

C.2 AVIATION

TREASURE COAST INTERNATIONAL AIRPORT 10R SAFETY AREA DITCH RELOCATION
4515581 Non-SIS

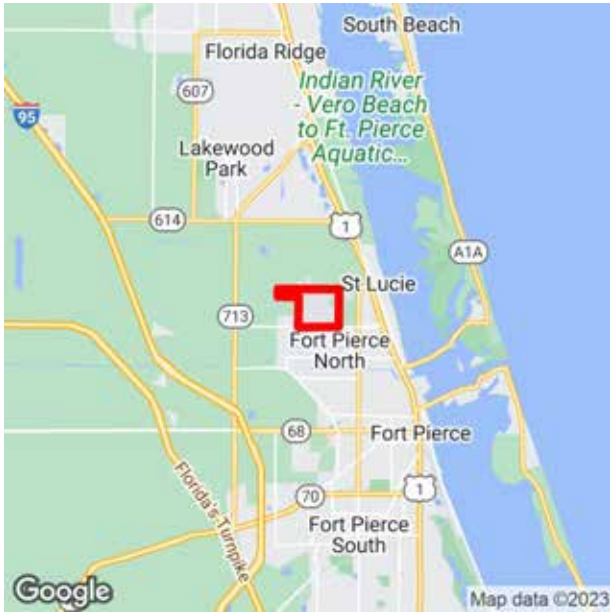

Project Description: AVIATION PRESERVATION PROJECT
Extra Description: CONSTRUCTION
Lead Agency: RESPONSIBLE AGENCY NOT AVAILABLE
From:
To:
Length: 0
Phase Group: CAPITAL

Phase	Fund Code	2025	2026	2027	2028	2029	Total
CAP	DPTO	0	20,475	0	0	0	20,475
CAP	FAA	0	368,550	0	0	0	368,550
CAP	LF	0	20,475	0	0	0	20,475
			409,500				409,500

Prior Year Cost: 0
Future Year Cost: 0
Total Project Cost: 409,500
LRTP: Page 3-9

TREASURE COAST INTERNATIONAL AIRPORT 10R SAFETY AREA DITCH RELOCATION
4515591 Non-SIS

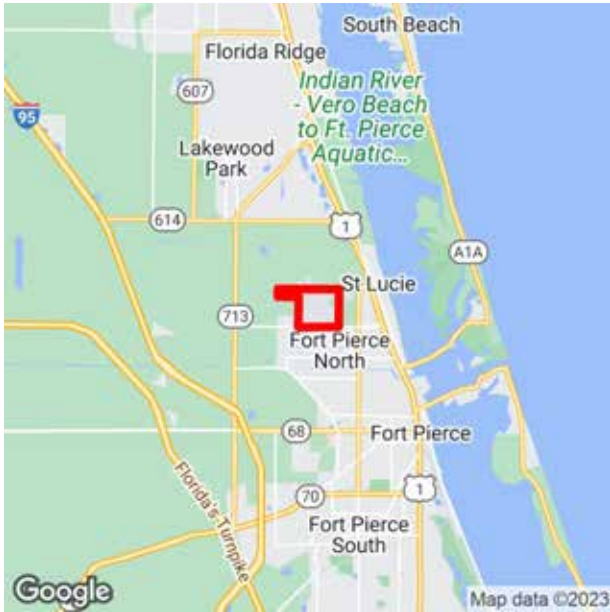

Project Description: AVIATION PRESERVATION PROJECT
Lead Agency: RESPONSIBLE AGENCY NOT AVAILABLE
From:
To:
Length: 0
Phase Group: CAPITAL

Phase	Fund Code	2025	2026	2027	2028	2029	Total
CAP	DPTO	0	2,000,000	0	0	0	2,000,000
CAP	LF	0	500,000	0	0	0	500,000
		2,500,000					2,500,000

Prior Year Cost: 0
Future Year Cost: 0
Total Project Cost: 2,500,000
LRTP: Page 3-9

TREASURE COAST INTERNATIONAL AIRPORT AEROWEST TAXIWAY (CONSTRUCTION)

4481151 Non-SIS

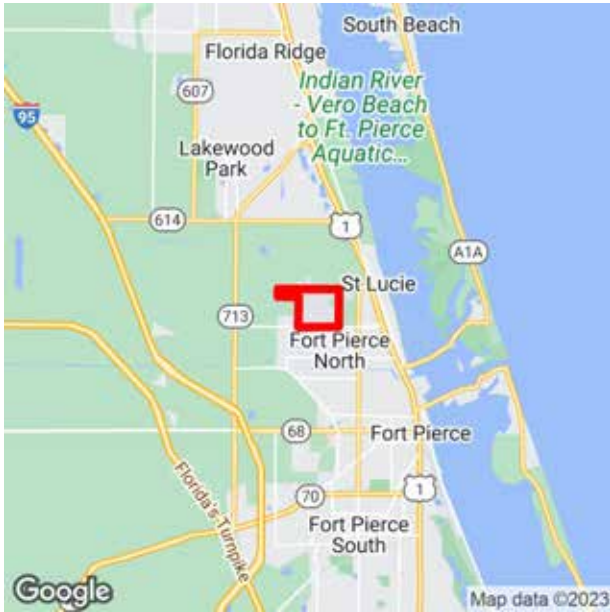

Project Description: AVIATION CAPACITY PROJECT

Lead Agency: RESPONSIBLE AGENCY NOT

From:

AVAILABLE

To:

Length: 0

Phase Group: CAPITAL

Phase	Fund Code	2025	2026	2027	2028	2029	Total
CAP	DPTO	1,200,000	0	0	0	0	1,200,000
CAP	LF	300,000	0	0	0	0	300,000
		1,500,000					1,500,000

Prior Year Cost: 1,500,000

Future Year Cost: 0

Total Project Cost: 3,000,000

LRTP: Page 3-9

TREASURE COAST INTERNATIONAL AIRPORT AIRCRAFT RESCUE & FIREFIGHTING REPLACEMENT
4515571 Non-SIS

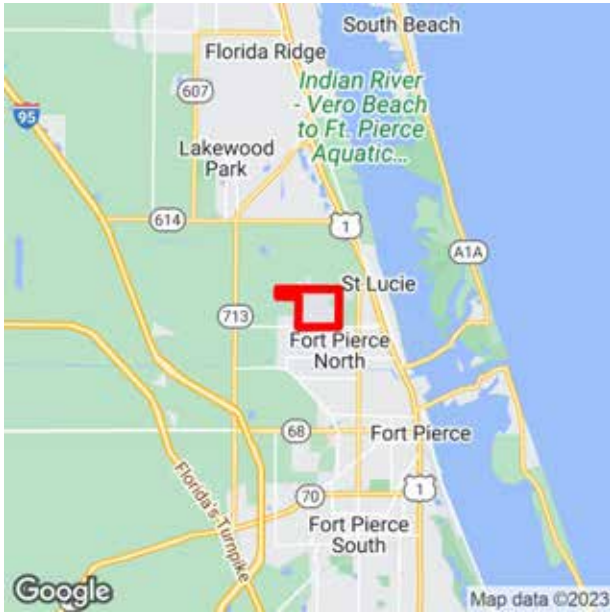

Project Description: AVIATION SAFETY PROJECT

Lead Agency: RESPONSIBLE AGENCY NOT

AVAILABLE

Length: 0

Phase Group: CAPITAL

From:

To:

Phase	Fund Code	2025	2026	2027	2028	2029	Total
CAP	DPTO	0	640,000	0	0	0	640,000
CAP	LF	0	160,000	0	0	0	160,000
		800,000					800,000

Prior Year Cost: 0

Future Year Cost: 0

Total Project Cost: 800,000

LRTP: Page 3-9

TREASURE COAST INTERNATIONAL AIRPORT INSTRUMENT LANDING SYSTEM REPLACEMENT 10R/28L
4515561 Non-SIS

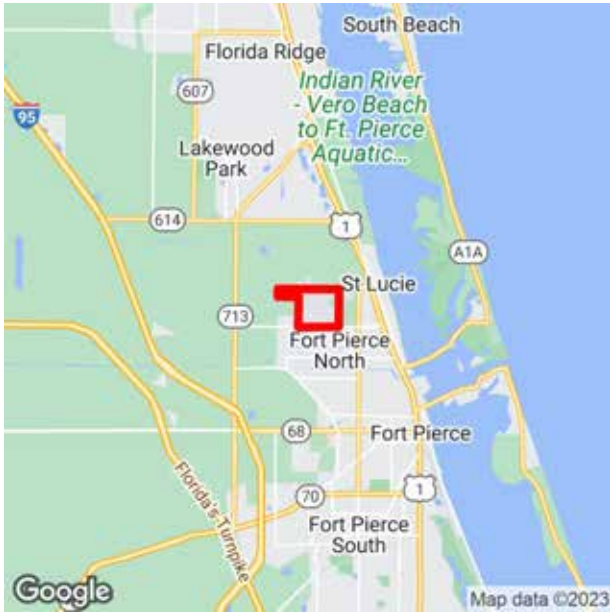

Project Description: AVIATION PRESERVATION PROJECT
Lead Agency: RESPONSIBLE AGENCY NOT AVAILABLE
From:
To:
Length: 0
Phase Group: CAPITAL

Phase	Fund Code	2025	2026	2027	2028	2029	Total
CAP	DPTO	0	400,000	0	0	0	400,000
CAP	LF	0	100,000	0	0	0	100,000
		500,000					500,000

Prior Year Cost: 0
Future Year Cost: 0
Total Project Cost: 500,000
LRTP: Page 3-9

TREASURE COAST INTERNATIONAL AIRPORT LAYOUT PLAN AND MASTER PLAN UPDATE
4533811 Non-SIS

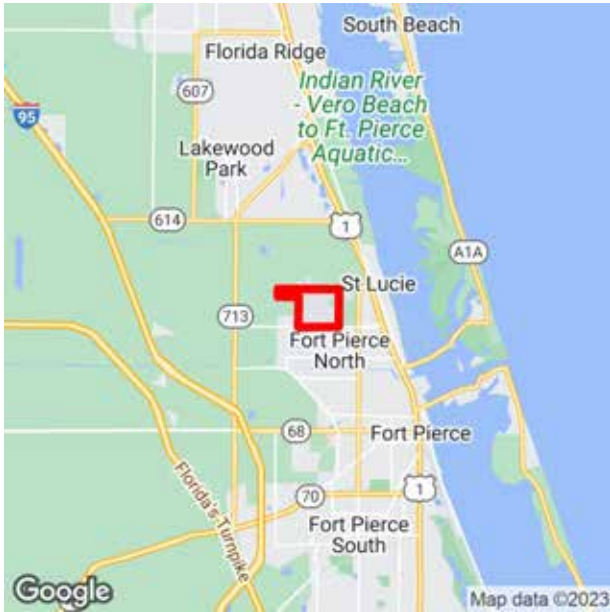

Project Description: AVIATION CAPACITY PROJECT
Lead Agency: RESPONSIBLE AGENCY NOT AVAILABLE
From:
To:
Length: 0
Phase Group: CAPITAL

Phase	Fund Code	2025	2026	2027	2028	2029	Total
CAP	DPTO	0	0	400,000	0	0	400,000
CAP	LF	0	0	100,000	0	0	100,000
				500,000			500,000

Prior Year Cost: 0
Future Year Cost: 0
Total Project Cost: 500,000
LRTP: Page 3-9

TREASURE COAST INTERNATIONAL AIRPORT MAINTENANCE AND OPERATIONS

4533801 Non-SIS

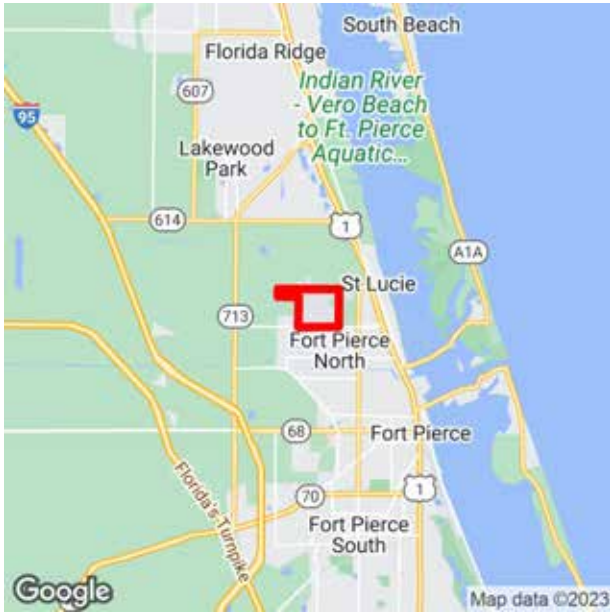

Project Description: AVIATION REVENUE/OPERATIONAL

Extra Description: BUILDING - DESIGN

Lead Agency: RESPONSIBLE AGENCY NOT

From:

AVAILABLE

To:

Length: 0

Phase Group: CAPITAL

Phase	Fund Code	2025	2026	2027	2028	2029	Total
CAP	DPTO	0	0	280,000	0	0	280,000
CAP	LF	0	0	70,000	0	0	70,000
				350,000			350,000

Prior Year Cost: 0

Future Year Cost: 0

Total Project Cost: 350,000

LRTP: Page 3-9

TREASURE COAST INTERNATIONAL AIRPORT TAXIWAY ALPHA RWY 14/32
4515361 Non-SIS

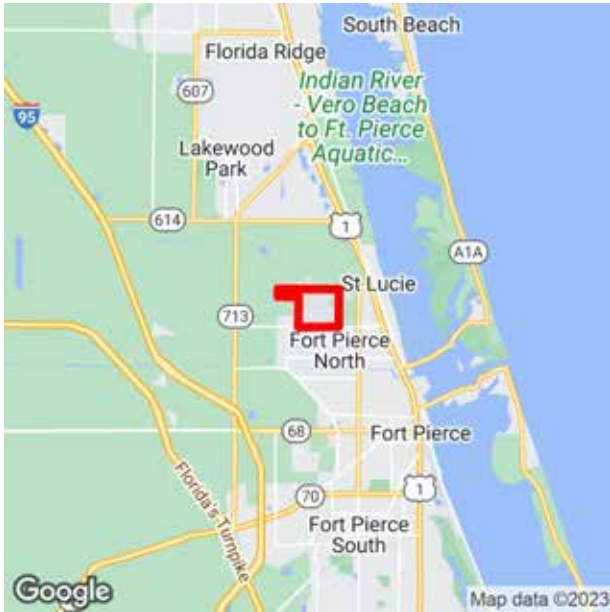

Project Description: AVIATION PRESERVATION PROJECT
Extra Description: INTERSECTION REHAB - DESIGN
Lead Agency: RESPONSIBLE AGENCY NOT AVAILABLE
From:
To:
Length: 0
Phase Group: CAPITAL

Phase	Fund Code	2025	2026	2027	2028	2029	Total
CAP	DPTO	120,000	0	0	0	0	120,000
CAP	LF	30,000	0	0	0	0	30,000
		150,000					150,000

Prior Year Cost: 0
Future Year Cost: 0
Total Project Cost: 150,000
LRTP: Page 3-9

TREASURE COAST INTERNATIONAL AIRPORT TAXIWAY ECHO REHAB - DESIGN

4515551 Non-SIS

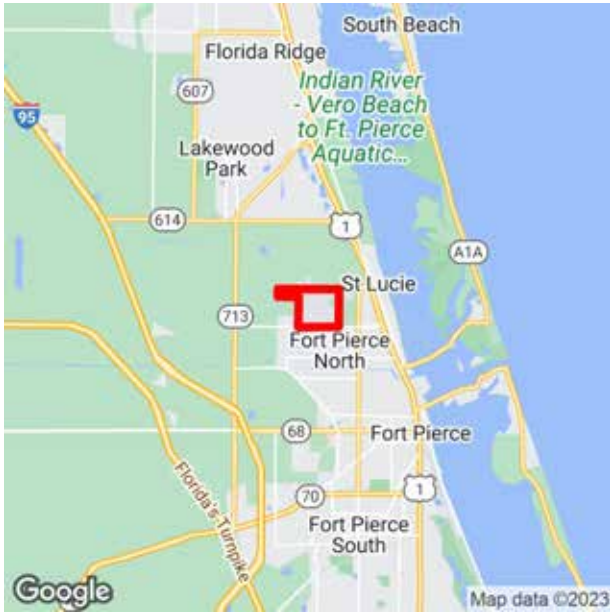

Project Description: AVIATION PRESERVATION PROJECT
Lead Agency: RESPONSIBLE AGENCY NOT AVAILABLE
From:
To:
Length: 0
Phase Group: CAPITAL

Phase	Fund Code	2025	2026	2027	2028	2029	Total
CAP	DPTO	0	100,000	0	0	0	100,000
CAP	LF	0	25,000	0	0	0	25,000
			125,000				125,000

Prior Year Cost: 0
Future Year Cost: 0
Total Project Cost: 125,000
LRTP: Page 3-9

TREASURE COAST INTERNATIONAL AIRPORT WEST GA RAMP REHAB CONSTRUCTION
4533821 Non-SIS

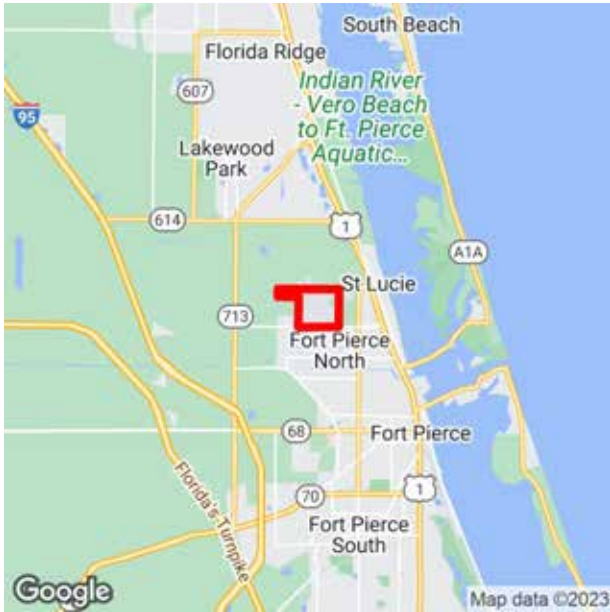

Project Description: AVIATION PRESERVATION PROJECT
Lead Agency: RESPONSIBLE AGENCY NOT AVAILABLE
From:
To:
Length: 0
Phase Group: CAPITAL

Phase	Fund Code	2025	2026	2027	2028	2029	Total
CAP	DPTO	0	0	600,000	0	0	600,000
CAP	LF	0	0	150,000	0	0	150,000
				750,000			750,000

Prior Year Cost: 0
Future Year Cost: 0
Total Project Cost: 750,000
LRTP: Page 3-9

TREASURE COAST INTERNATIONAL AIRPORT WEST GA RAMP REHAB DESIGN

4515601 Non-SIS

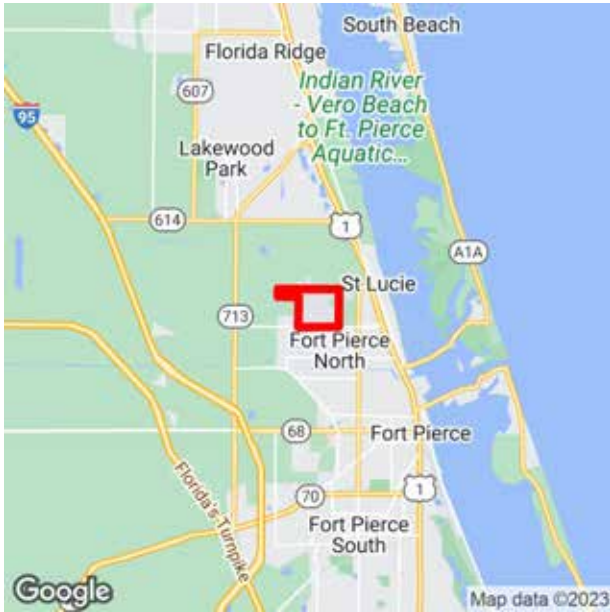

Project Description: AVIATION PRESERVATION PROJECT

Lead Agency: RESPONSIBLE AGENCY NOT AVAILABLE

From:

Length: 0

To:

Phase Group: CAPITAL

Phase	Fund Code	2025	2026	2027	2028	2029	Total
CAP	DPTO	0	200,000	0	0	0	200,000
CAP	LF	0	50,000	0	0	0	50,000
		250,000					250,000

Prior Year Cost: 0

Future Year Cost: 0

Total Project Cost: 250,000

LRTP: Page 3-9

C.3 TRANSIT PROJECTS

PORT ST. LUCIE INTERMODAL CENTER CAPITAL IMPROVEMENTS

4531911 Non-SIS

Prior Year Cost: 600,000

Future Year Cost: 0

Total Project Cost: 1,500,000

LRTP: Page 3-9

Project Description: INTERMODAL HUB CAPACITY

Extra Description: INTERMODAL CENTER ACCESS AND SAFETY IMPROVEMENTS

Lead Agency: MANAGED BY ST. LUCIE COUNTY **From:**

Length: 0

To:

Phase Group: CAPITAL

Phase	Fund Code	2025	2026	2027	2028	2029	Total
CAP	DDR	900,000	0	0	0	0	900,000
		900,000					900,000

PSL UZA - ST. LUCIE COUNTY SECT 5339 CAPITAL FOR BUS & BUS FACILITIES

4345481 Non-SIS

Prior Year Cost: 2,404,114

Future Year Cost: 0

Total Project Cost: 3,779,114

LRTP: Page 3-9

Project Description: CAPITAL FOR FIXED ROUTE

Extra Description: ST.LUCIE CNTY SECTION 5339 CAPITAL FOR BUS & BUS FACILITIES PROGRAM
16. CAPITAL FOR FIXED ROUTE NON-BUDGET REVENUE

Lead Agency: MANAGED BY ST. LUCIE COUNTY **From:**

Length: 0

To:

Phase Group: CAPITAL

Phase	Fund Code	2025	2026	2027	2028	2029	Total
CAP	FTA	275,000	275,000	275,000	275,000	275,000	1,375,000
		275,000	275,000	275,000	275,000	275,000	1,375,000

**PSL UZA - ST. LUCIE COUNTY SECTION 5307 FORMULA FUNDS
4134941 Non-SIS**

Prior Year Cost: 38,614,273
Future Year Cost: 0
Total Project Cost: 50,714,273
LRTP: Page 3-9

Project Description: CAPITAL FOR FIXED ROUTE
Extra Description: FY11 - GRANT FL-90-X727 EXECUTED PER K.SCOTT-ST.LUCIE CO EMAIL FROM J. MELI 10/13/10. GRANT FL90-X765 EXECUTED 10/20/11 \$1,407,322 EMAIL FROM K. SCOTT/SLC 1-11-12 TO J. MELI. ST.LUCIE COUNTY SEC 5307 OPERATING ASSISTANCE NON-BUDGET REVENUE
Lead Agency: MANAGED BY ST. LUCIE COA **From:**
Length: 0 **To:**
Phase Group: OPERATIONS, CAPITAL

Phase	Fund Code	2025	2026	2027	2028	2029	Total
OPS	FTA	810,000	810,000	810,000	810,000	810,000	4,050,000
CAP	FTA	1,610,000	1,610,000	1,610,000	1,610,000	1,610,000	8,050,000
		2,420,000	2,420,000	2,420,000	2,420,000	2,420,000	12,100,000

**ST. LUCIE COUNTY BLOCK GRANT OPERATING ASSISTANCE
4071874 Non-SIS**

Prior Year Cost: 0
Future Year Cost: 0
Total Project Cost: 8,910,744
LRTP: Page 3-9

Project Description: OPERATING/ADMIN. ASSISTANCE
Lead Agency: MANAGED BY ST. LUCIE COUNTY **From:**
Length: 0 **To:**
Phase Group: OPERATIONS

Phase	Fund Code	2025	2026	2027	2028	2029	Total
OPS	DDR	690,467	991,520	817,389	841,911	841,911	4,183,198
OPS	DPTO	272,174	0	0	0	0	272,174
OPS	LF	962,641	991,520	817,389	841,911	841,911	4,455,372
		1,925,282	1,983,040	1,634,778	1,683,822	1,683,822	8,910,744

**ST. LUCIE COUNTY SECTION 5311 OPERATING RURAL FUNDS
4071855 Non-SIS**

Prior Year Cost: 0
Future Year Cost: 0
Total Project Cost: 882,778
LRTP: Page 3-9

Project Description: OPERATING/ADMIN. ASSISTANCE
Lead Agency: MANAGED BY ST. LUCIE COUNTY **From:**
Length: 0 **To:**
Phase Group: OPERATIONS

Phase	Fund Code	2025	2026	2027	2028	2029	Total
OPS	DU	81,206	85,029	89,038	93,058	93,058	441,389
OPS	LF	81,206	85,029	89,038	93,058	93,058	441,389
		162,412	170,058	178,076	186,116	186,116	882,778

**ST. LUCIE TRANSIT CORRIDOR LAKEWOOD PARK REGIONAL ROUTE
4446641 Non-SIS**

Prior Year Cost: 1,040,000
Future Year Cost: 0
Total Project Cost: 1,640,000
LRTP: Page 3-9

Project Description: OPERATING FOR FIXED ROUTE
Extra Description: REGIONAL ROUTE, ST. LUCIE - INDIAN RIVER COUNTIES
Lead Agency: MANAGED BY ST. LUCIE COUNTY **From:**
Length: 0 **To:**
Phase Group: OPERATIONS

Phase	Fund Code	2025	2026	2027	2028	2029	Total
OPS	DPTO	300,000	300,000	0	0	0	600,000
		300,000	300,000				600,000

C.4 MISCELLANEOUS PROJECTS

**CITY OF FT. PIERCE JPA SIGNAL MAINTENANCE & OPERATIONS ON SHS
4379751 Non-SIS**

Prior Year Cost: 896,075
Future Year Cost: 0
Total Project Cost: 1,769,199
LRTP: Page 3-9

Project Description: TRAFFIC SIGNALS
Lead Agency: MANAGED BY CITY OF FORT PIERCE
Length: 0
Phase Group: OPERATIONS
From:
To:

Phase	Fund Code	2025	2026	2027	2028	2029	Total
OPS	DDR	102,229	105,509	129,117	0	0	336,855
OPS	DITS	172,028	185,203	179,038	0	0	536,269
		274,257	290,712	308,155			873,124

**CITY OF FT. PIERCE JPA SIGNAL MAINTENANCE & OPS ON STATE HWY SYSTEM
4515811 Non-SIS**

Prior Year Cost: 0
Future Year Cost: 0
Total Project Cost: 959,696
LRTP: Page 3-9

Project Description: TRAFFIC SIGNALS
Extra Description: NEW MSCA TARGET STARTING IN FY28
Lead Agency: RESPONSIBLE AGENCY NOT AVAILABLE **From:**
Length: 0 **To:**
Phase Group: BRDG/RDWY/CONTRACT MAINT

Phase	Fund Code	2025	2026	2027	2028	2029	Total
MNT	D	0	0	0	413,972	545,724	959,696
					413,972	545,724	959,696

**CITY OF PORT ST. LUCIE JPA SIGNAL MAINTENANCE & OPERATIONS ON SHS
4379771 Non-SIS**

Prior Year Cost: 478,464
Future Year Cost: 0
Total Project Cost: 905,111
LRTP: Page 3-9

Project Description: TRAFFIC SIGNALS
Lead Agency: MANAGED BY CITY OF PORT ST. LUCIE
Length: 0
Phase Group: OPERATIONS
From:
To:

Phase	Fund Code	2025	2026	2027	2028	2029	Total
OPS	DDR	57,894	79,978	77,210	0	0	215,082
OPS	DITS	76,120	62,077	73,368	0	0	211,565
		134,014	142,055	150,578			426,647

**CITY OF PORT ST. LUCIE JPA SIGNAL MAINTENANCE & OPS ON SHS
4515831 Non-SIS**

Prior Year Cost: 0
Future Year Cost: 0
Total Project Cost: 445,214
LRTP: Page 3-9

Project Description: TRAFFIC SIGNALS
Extra Description: NEW MSCA TARGET STARTING IN FY28
Lead Agency: RESPONSIBLE AGENCY NOT AVAILABLE **From:**
Length: 0 **To:**
Phase Group: BRDG/RDWY/CONTRACT MAINT

Phase	Fund Code	2025	2026	2027	2028	2029	Total
MNT	D	0	0	0	192,046	253,168	445,214
					192,046	253,168	445,214

**ST. LUCIE - PRIMARY MOWING AND LITTER CONTRACT
4480521 Non-SIS**

Prior Year Cost: 500,000
Future Year Cost: 0
Total Project Cost: 1,500,000
LRTP: Page 3-9

Project Description: ROUTINE MAINTENANCE
Lead Agency: MANAGED BY FDOT
Length: 0
Phase Group: BRDG/RDWY/CONTRACT MAINT

From:
To:

Phase	Fund Code	2025	2026	2027	2028	2029	Total
MNT	D	250,000	0	0	0	0	250,000
		250,000					250,000

**ST. LUCIE - PRIMARY MOWING AND LITTER CONTRACT
4480522 Non-SIS**

Prior Year Cost: 500,000
Future Year Cost: 0
Total Project Cost: 1,500,000
LRTP: Page 3-9

Project Description: ROUTINE MAINTENANCE
Lead Agency: MANAGED BY FDOT
Length: 0
Phase Group: BRDG/RDWY/CONTRACT MAINT

From:
To:

Phase	Fund Code	2025	2026	2027	2028	2029	Total
MNT	D	0	250,000	250,000	250,000	0	750,000
			250,000	250,000	250,000		750,000

**ST. LUCIE COUNTY INTERSTATE-ROADWAY
2343761 SIS**

Prior Year Cost: 6,119,519
Future Year Cost: 0
Total Project Cost: 6,164,519
LRTP: Page 3-9

Project Description: ROUTINE MAINTENANCE
Lead Agency: MANAGED BY FDOT
Length: 0
Phase Group: BRDG/RDWY/CONTRACT MAINT

From:
To:

Phase	Fund Code	2025	2026	2027	2028	2029	Total
MNT	D	5,000	5,000	5,000	5,000	5,000	25,000
		5,000	5,000	5,000	5,000	5,000	25,000

**ST. LUCIE COUNTY JPA SIGNAL MAINTENANCE & OPERATIONS ON SHS
4379761 Non-SIS**

Prior Year Cost: 1,128,564
Future Year Cost: 0
Total Project Cost: 1,998,759
LRTP: Page 3-9

Project Description: TRAFFIC SIGNALS
Lead Agency: MANAGED BY ST LUCIE COUNTY **From:**
Length: 0 **To:**
Phase Group: OPERATIONS

Phase	Fund Code	2025	2026	2027	2028	2029	Total
OPS	DDR	0	57,451	147,334	0	0	204,785
OPS	DITS	273,337	232,286	159,787	0	0	665,410
		273,337	289,737	307,121			870,195

**ST. LUCIE COUNTY JPA SIGNAL MAINTENANCE & OPS ON STATE HWY SYSTEM
4515821 Non-SIS**

Prior Year Cost: 0
Future Year Cost: 0
Total Project Cost: 906,274
LRTP: Page 3-9

Project Description: TRAFFIC SIGNALS
Extra Description: NEW MSCA TARGET STARTING IN FY28
Lead Agency: RESPONSIBLE AGENCY NOT AVAILABLE **From:**
Length: 0 **To:**
Phase Group: BRDG/RDWY/CONTRACT MAINT

Phase	Fund Code	2025	2026	2027	2028	2029	Total
MNT	D	0	0	0	390,928	515,346	906,274
					390,928	515,346	906,274

**ST. LUCIE COUNTY STATE HIGHWAY SYSTEM RDWAY
2338591 Non-SIS**

Prior Year Cost: 62,184,246
Future Year Cost: 0
Total Project Cost: 69,824,246
LRTP: Page 3-9

Project Description: ROUTINE MAINTENANCE
Lead Agency: MANAGED BY FDOT **From:**
Length: 0 **To:**
Phase Group: BRDG/RDWAY/CONTRACT MAINT

Phase	Fund Code	2025	2026	2027	2028	2029	Total
MNT	D	1,500,000	1,500,000	1,500,000	1,500,000	1,500,000	7,500,000
		1,500,000	1,500,000	1,500,000	1,500,000	1,500,000	7,500,000

TREASURE COAST OPERATIONS - ADMIN ROOF REPLACEMENT

4468956 Non-SIS

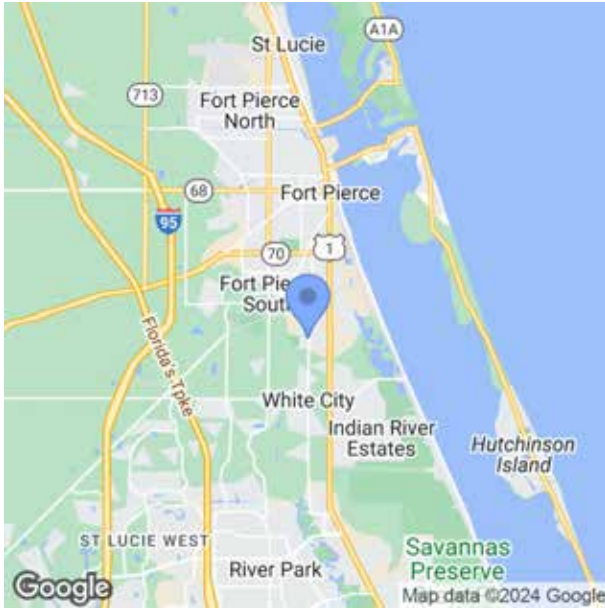

Project Description: FIXED CAPITAL OUTLAY

Lead Agency: MANAGED BY FDOT

Length: 0

Phase Group: CONSTRUCTION

From:

To:

Phase	Fund Code	2025	2026	2027	2028	2029	Total
CST	FCO	175,000	0	0	0	0	175,000
		175,000					175,000

Prior Year Cost: 0

Future Year Cost: 0

Total Project Cost: 210,000

LRTP: Page 3-9

TREASURE COAST OPERATIONS - BATHROOM UPGRADE
4500544 Non-SIS

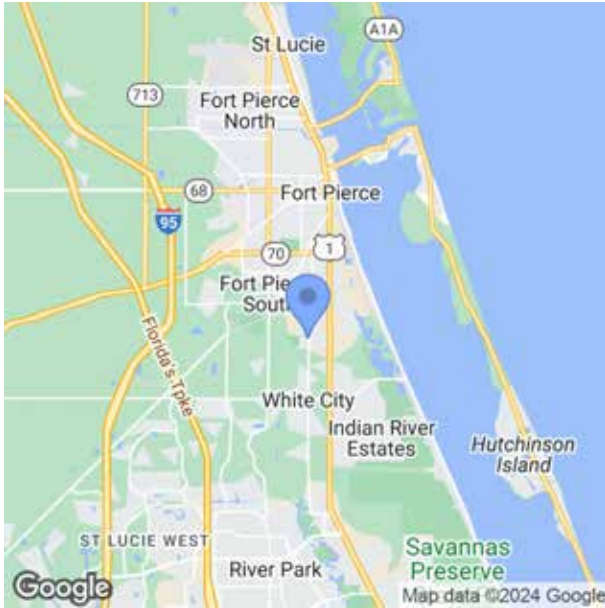

Project Description: FIXED CAPITAL OUTLAY
Lead Agency: MANAGED BY FDOT
Length: 0
Phase Group: CONSTRUCTION

From:
To:

Phase	Fund Code	2025	2026	2027	2028	2029	Total
CST	FCO	0	160,000	0	0	0	160,000
			160,000				160,000

Prior Year Cost: 0
Future Year Cost: 0
Total Project Cost: 505,000
LRTP: Page 3-9

TREASURE COAST OPERATIONS - CONSTRUCT TRUCK REPAIR CANOPY (30X20)
4468959 Non-SIS



Project Description: FIXED CAPITAL OUTLAY
Lead Agency: MANAGED BY FDOT
Length: 0
Phase Group: CONSTRUCTION

From:
To:

Phase	Fund Code	2025	2026	2027	2028	2029	Total
CST	FCO	0	35,000	0	0	0	35,000
			35,000				35,000

Prior Year Cost: 0
Future Year Cost: 0
Total Project Cost: 210,000
LRTP: Page 3-9

TREASURE COAST OPERATIONS - EMERGENCY GENERATOR FOR TRADES

4500545 Non-SIS

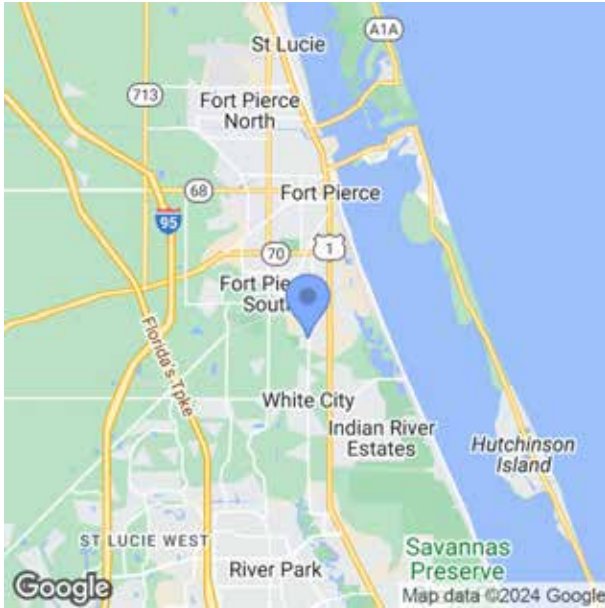

Project Description: FIXED CAPITAL OUTLAY
Lead Agency: MANAGED BY FDOT
Length: 0
Phase Group: CONSTRUCTION

From:
To:

Phase	Fund Code	2025	2026	2027	2028	2029	Total
CST	FCO	0	0	60,000	0	0	60,000
				60,000			60,000

Prior Year Cost: 0
Future Year Cost: 0
Total Project Cost: 505,000
LRTP: Page 3-9

TREASURE COAST OPERATIONS - GARAGE DOOR REPLACEMENT
4500543 Non-SIS

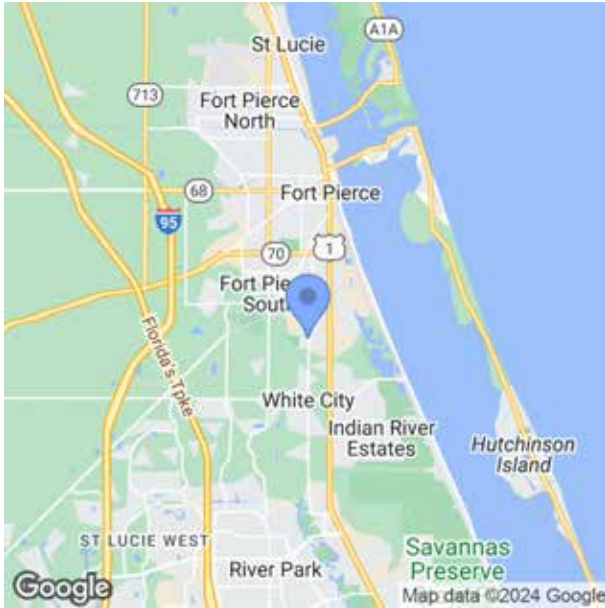

Project Description: FIXED CAPITAL OUTLAY
Lead Agency: MANAGED BY FDOT
Length: 0
Phase Group: CONSTRUCTION

From:
To:

Phase	Fund Code	2025	2026	2027	2028	2029	Total
CST	FCO	0	120,000	0	0	0	120,000
			120,000				120,000

Prior Year Cost: 0
Future Year Cost: 0
Total Project Cost: 505,000
LRTP: Page 3-9

TREASURE COAST OPERATIONS - PROJECT ADMINISTRATION BLDG ROOF

4500546 Non-SIS

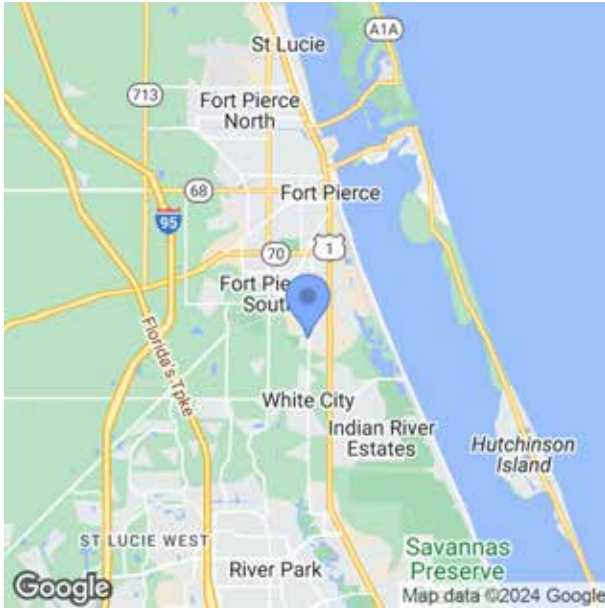

Project Description: FIXED CAPITAL OUTLAY
Lead Agency: MANAGED BY FDOT
Length: 0
Phase Group: CONSTRUCTION

From:
To:

Phase	Fund Code	2025	2026	2027	2028	2029	Total
CST	FCO	0	0	0	80,000	0	80,000
					80,000		80,000

Prior Year Cost: 0
Future Year Cost: 0
Total Project Cost: 505,000
LRTP: Page 3-9

TREASURE COAST OPERATIONS STORM SHUTTERS INSTALLATION
4500549 Non-SIS

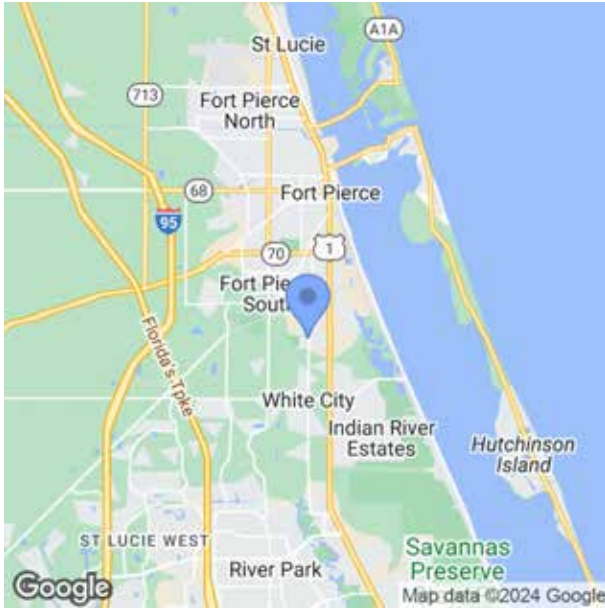

Project Description: FIXED CAPITAL OUTLAY
Lead Agency: MANAGED BY FDOT
Length: 0
Phase Group: CONSTRUCTION

From:
To:

Phase	Fund Code	2025	2026	2027	2028	2029	Total
CST	FCO	0	0	50,000	0	0	50,000
				50,000			50,000

Prior Year Cost: 0
Future Year Cost: 0
Total Project Cost: 505,000
LRTP: Page 3-9

TREASURE COAST OPERATIONS- AC REPLACEMENT
4516333 Non-SIS

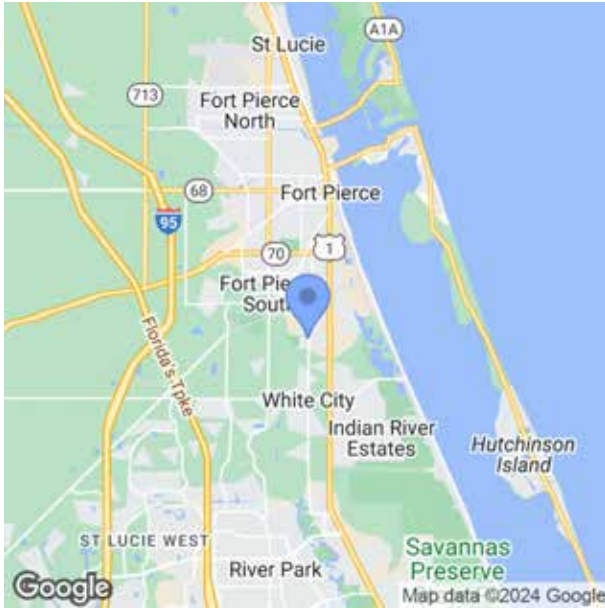

Project Description: FIXED CAPITAL OUTLAY
Lead Agency: MANAGED BY FDOT
Length: 0
Phase Group: BRDG/RDWDY/CONTRACT MAINT

From:
To:

Phase	Fund Code	2025	2026	2027	2028	2029	Total
MNT	D	0	0	80,000	0	0	80,000
				80,000			80,000

Prior Year Cost: 0
Future Year Cost: 0
Total Project Cost: 140,000
LRTP: Page 3-9

TREASURE COAST OPERATIONS- REPLACE TILE - SHOP & WAREHOUSE

4516331 Non-SIS

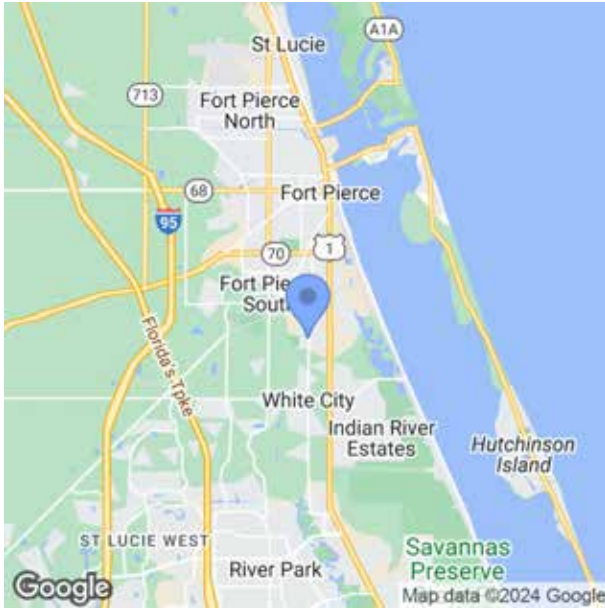

Project Description: FIXED CAPITAL OUTLAY
Lead Agency: MANAGED BY FDOT
Length: 0
Phase Group: BRDG/RDWY/CONTRACT MAINT

From:
To:

Phase	Fund Code	2025	2026	2027	2028	2029	Total
MNT	D	0	0	0	25,000	0	25,000
					25,000		25,000

Prior Year Cost: 0
Future Year Cost: 0
Total Project Cost: 140,000
LRTP: Page 3-9

**TREASURE COAST OPERATIONS- RESURFACING PARKING LOT
4516321 Non-SIS**

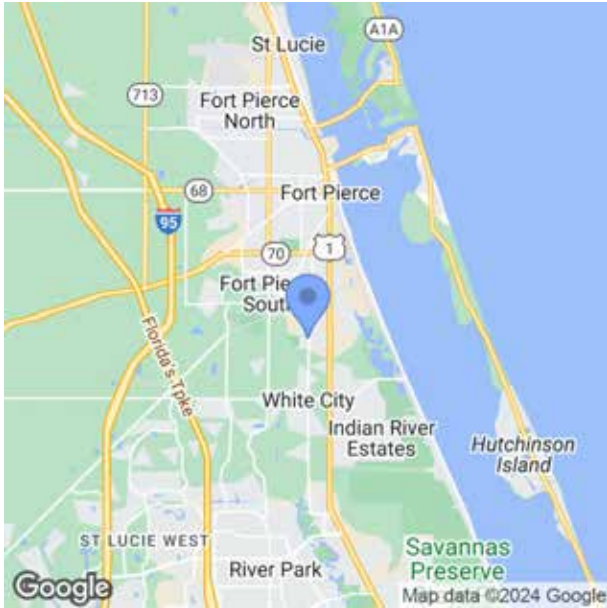

Project Description: FIXED CAPITAL OUTLAY
Lead Agency: MANAGED BY FDOT
Length: 0
Phase Group: CONSTRUCTION

From:
To:

Phase	Fund Code	2025	2026	2027	2028	2029	Total
CST	FCO	0	0	300,000	0	0	300,000
				300,000			300,000

Prior Year Cost: 0
Future Year Cost: 0
Total Project Cost: 300,000
LRTP: Page 3-9

TREASURE COAST OPERATIONS-PAINTING PROJECT ADMINISTRATION BLDG
4500548 Non-SIS

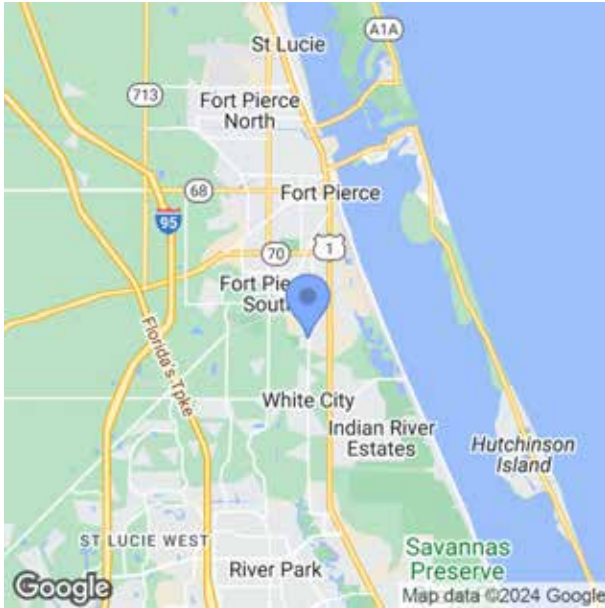

Project Description: FIXED CAPITAL OUTLAY
Lead Agency: MANAGED BY FDOT
Length: 0
Phase Group: CONSTRUCTION

From:
To:

Phase	Fund Code	2025	2026	2027	2028	2029	Total
CST	FCO	0	0	0	0	25,000	25,000
						25,000	25,000

Prior Year Cost: 0
Future Year Cost: 0
Total Project Cost: 505,000
LRTP: Page 3-9

TREASURE COAST OPERATIONS-SECURITY CAMERAS UPGRADE
4516332 Non-SIS

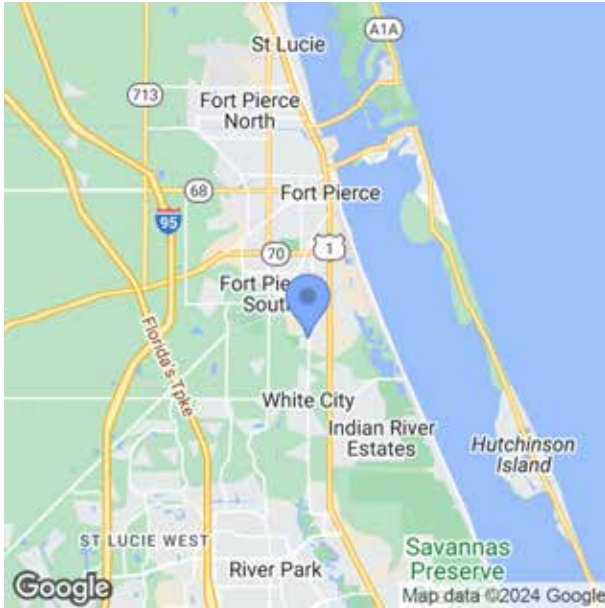

Project Description: FIXED CAPITAL OUTLAY
Lead Agency: MANAGED BY FDOT
Length: 0
Phase Group: BRDG/RDWY/CONTRACT MAINT

From:
To:

Phase	Fund Code	2025	2026	2027	2028	2029	Total
MNT	D	0	0	0	35,000	0	35,000
					35,000		35,000

Prior Year Cost: 0
Future Year Cost: 0
Total Project Cost: 140,000
LRTP: Page 3-9

TREASURE COAST OPERATIONS-TILE INSTALLATION PROJECT ADMIN BLDG
4500547 Non-SIS

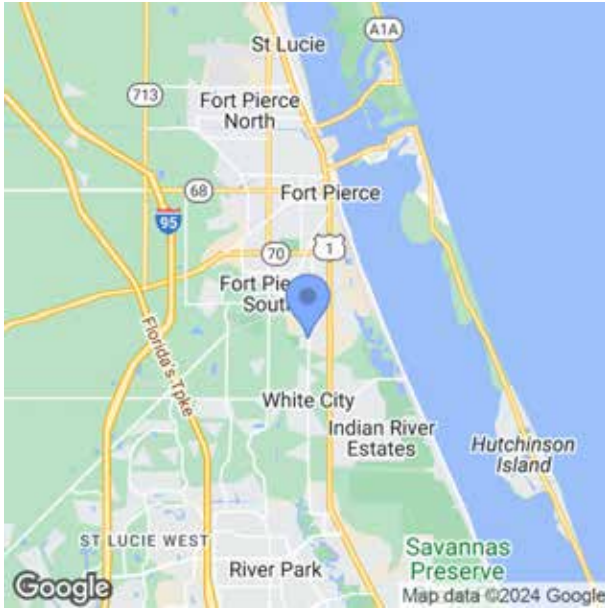

Project Description: FIXED CAPITAL OUTLAY
Lead Agency: MANAGED BY FDOT
Length: 0
Phase Group: CONSTRUCTION

From:
To:

Phase	Fund Code	2025	2026	2027	2028	2029	Total
CST	FCO	0	10,000	0	0	0	10,000
			10,000				10,000

Prior Year Cost: 0
Future Year Cost: 0
Total Project Cost: 505,000
LRTP: Page 3-9

C.5 PLANNING PROJECTS

**ST. LUCIE FY 2024/2025-2025/2026 UPWP
4393265 Non-SIS**

Prior Year Cost: 0
Future Year Cost: 0
Total Project Cost: 6,053,372
LRTP: Page 3-9

Project Description: TRANSPORTATION PLANNING
Lead Agency: RESPONSIBLE AGENCY NOT AVAILABLE **From:**
Length: 0 **To:**
Phase Group: PLANNING

Phase	Fund Code	2025	2026	2027	2028	2029	Total
PLN	ACSU	400,000	0	0	0	0	400,000
PLN	PL	803,048	812,581	0	0	0	1,615,629
PLN	SU	0	400,000	0	0	0	400,000
		1,203,048	1,212,581				2,415,629

**ST. LUCIE FY 2026/2027-2027/2028 UPWP
4393266 Non-SIS**

Prior Year Cost: 0
Future Year Cost: 0
Total Project Cost: 6,053,372
LRTP: Page 3-9

Project Description: TRANSPORTATION PLANNING
Lead Agency: RESPONSIBLE AGENCY NOT AVAILABLE **From:**
Length: 0 **To:**
Phase Group: PLANNING

Phase	Fund Code	2025	2026	2027	2028	2029	Total
PLN	PL	0	0	812,581	812,581	0	1,625,162
PLN	SU	0	0	400,000	400,000	0	800,000
				1,212,581	1,212,581		2,425,162

**ST. LUCIE FY 2028/2029-2029/2030 UPWP
4393267 Non-SIS**

Prior Year Cost: 0
Future Year Cost: 0
Total Project Cost: 6,053,372
LRTP: Page 3-9

Project Description: TRANSPORTATION PLANNING
Lead Agency: RESPONSIBLE AGENCY NOT AVAILABLE **From:**
Length: 0 **To:**
Phase Group: PLANNING

Phase	Fund Code	2025	2026	2027	2028	2029	Total
PLN	PL	0	0	0	0	812,581	812,581
PLN	SU	0	0	0	0	400,000	400,000
						1,212,581	1,212,581

C.6 BRIDGE

A1A AT BIG MUD CREEK AND BLIND CREEK BRIDGES #940003/940004
4491791 Non-SIS

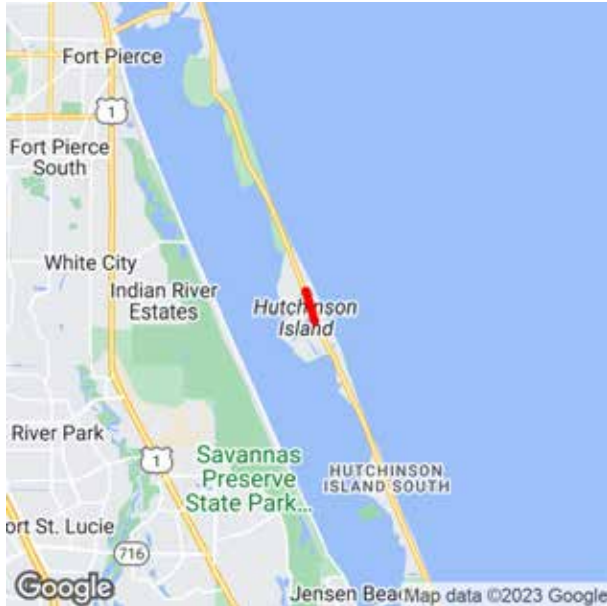

Project Description: BRIDGE REPLACEMENT
Extra Description: BRIDGE REPLACEMENT
Lead Agency: MANAGED BY FDOT **From:** BIG MUD CREEK BRIDGE
Length: 0.986 **To:** BLIND CREEK BRIDGE
Phase Group: PRELIMINARY ENGINEERING, RAILROAD & UTILITIES, CONSTRUCTION, ENVIRONMENTAL

Phase	Fund Code	2025	2026	2027	2028	2029	Total
RRU	ACBR	100,000	0	0	0	0	100,000
CST	ACBR	0	16,447,497	0	0	0	16,447,497
		100,000	16,447,497				16,547,497

Prior Year Cost: 1,081,989
Future Year Cost: 0
Total Project Cost: 17,629,486
LRTP: Page 3-9

A1A NORTH CAUSEWAY BRIDGE
4299362 Non-SIS

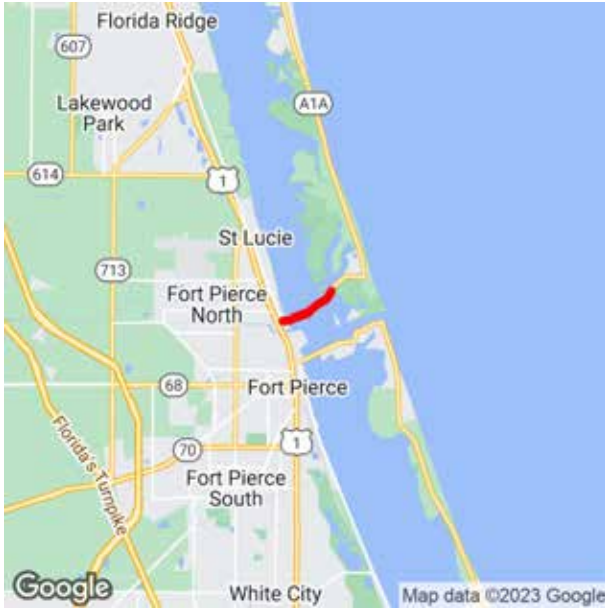

Project Description: BRIDGE REPLACEMENT

Extra Description: RISK WORKSHOP 32-02

Lead Agency: MANAGED BY FDOT

Length: 1.205

Phase Group: P D & E, PRELIMINARY ENGINEERING, RIGHT OF WAY, RAILROAD & UTILITIES, CONSTRUCTION, CONTRACT INCENTIVES, ENVIRONMENTAL

From: ENTIRE BRIDGE

To: ENTIRE BRIDGE

Phase	Fund Code	2025	2026	2027	2028	2029	Total
ROW	GFBR	8,676,339	0	0	0	0	8,676,339
CST	ACBR	1,029,000	0	0	0	0	1,029,000
		9,705,339					9,705,339

Prior Year Cost: 155,619,779

Future Year Cost: 0

Total Project Cost: 165,325,118

LRTP: Page 8-3

PORT ST. LUCIE BLVD OVER LONG CREEK & N FORK ST LUCIE RIVER BRDG

4435952 Non-SIS

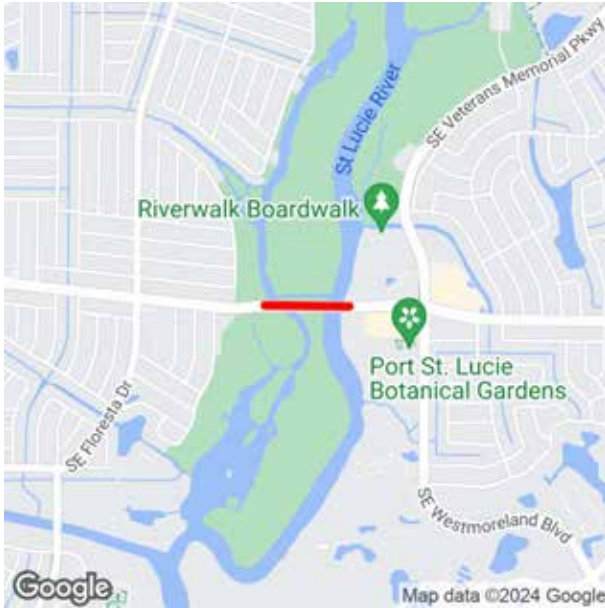

Project Description: BRIDGE-REPAIR/REHABILITATION
Lead Agency: MANAGED BY FDOT **From:** LONG CREEK
Length: 0.227 **To:** N FORK ST LUCIE RIVER BRDG
Phase Group: PRELIMINARY ENGINEERING, CONSTRUCTION

Phase	Fund Code	2025	2026	2027	2028	2029	Total
CST	BRRP	3,210,276	0	0	0	0	3,210,276
CST	DIH	12,605	0	0	0	0	12,605
		3,222,881					3,222,881

Prior Year Cost: 50,615
Future Year Cost: 0
Total Project Cost: 3,273,496
LRTP: Page 3-9

**ST. LUCIE COUNTY INTERSTATE BRIDGES
2343762 SIS**

Prior Year Cost: 6,119,519
Future Year Cost: 0
Total Project Cost: 6,164,519
LRTP: Page 3-9

Project Description: ROUTINE MAINTENANCE
Extra Description: PH 70 INCLUDES IN-HOUSE BRIDGE INSPECTIONS
Lead Agency: MANAGED BY FDOT **From:**
Length: 0 **To:**
Phase Group: BRDG/RDWY/CONTRACT MAINT

Phase	Fund Code	2025	2026	2027	2028	2029	Total
MNT	D	5,000	5,000	5,000	5,000	0	20,000
		5,000	5,000	5,000	5,000		20,000

ST. LUCIE COUNTY STATE HIGHWAY SYSTEM BRIDGES
2338592 Non-SIS

Prior Year Cost: 62,184,246
Future Year Cost: 0
Total Project Cost: 69,824,246
LRTP: Page 3-9

Project Description: ROUTINE MAINTENANCE
Extra Description: PH 70 INCLUDES IN-HOUSE BRIDGE INSPECTIONS
Lead Agency: MANAGED BY FDOT **From:**
Length: 0 **To:**
Phase Group: BRDG/RDWH/CONTRACT MAINT

Phase	Fund Code	2025	2026	2027	2028	2029	Total
MNT	D	35,000	35,000	35,000	35,000	0	140,000
		35,000	35,000	35,000	35,000		140,000

C.7 TURNPIKE ENTERPRISE PROJECTS

TURNPIKE @ MIDWAY RD SOUTHERN RAMPS INTERCHANGE (MP 150)
4518581 SIS

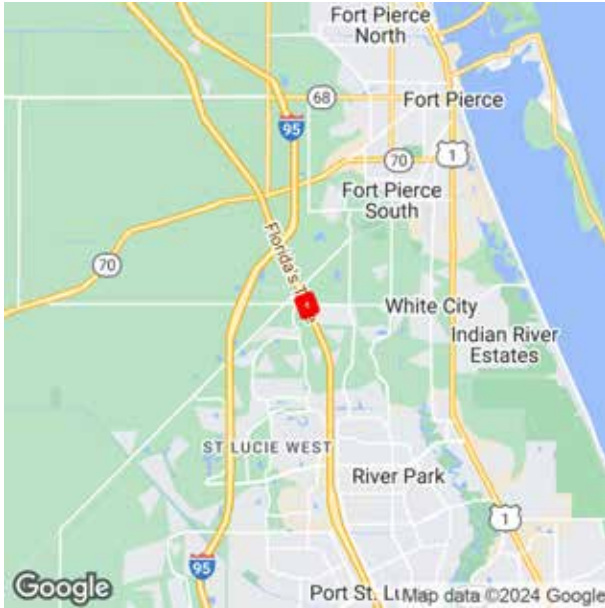

Project Description: INTERCHANGE RAMP (NEW)

Extra Description: THIS RELATES TO A DISTRICT 4 PROJECT (231440-4) TO WIDEN MIDWAY ROAD FROM 2-LANES TO 4-LANES. G/W 231440-4 (LEAD)

Lead Agency: MANAGED BY FDOT

From: INTERCHANGE

Length: 1.476

To: INTERCHANGE

Phase Group: PRELIMINARY ENGINEERING, RIGHT OF WAY, CONSTRUCTION

Phase	Fund Code	2025	2026	2027	2028	2029	Total
ROW	PKYI	5,770,000	8,679,799	0	0	0	14,449,799
CST	PKYI	0	0	17,301,911	0	0	17,301,911
		5,770,000	8,679,799	17,301,911			31,751,710

Prior Year Cost: 1,511,111

Future Year Cost: 0

Total Project Cost: 33,262,821

LRTP: Page 3-9

TURNPIKE INTERCHANGE IMPROVEMENTS AT SR-70 (MP 152)
4465801 SIS

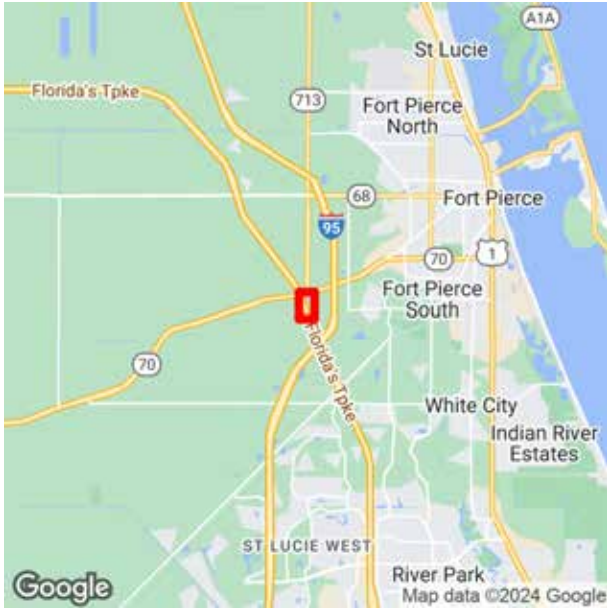

Project Description: INTERCHANGE IMPROVEMENT

Lead Agency: MANAGED BY FDOT

From: INTERCHANGE

Length: 0.8

To: INTERCHANGE

Phase Group: PRELIMINARY ENGINEERING

Phase	Fund Code	2025	2026	2027	2028	2029	Total
PE	PKYI	0	2,643,562	0	0	0	2,643,562
			2,643,562				2,643,562

Prior Year Cost: 19,870

Future Year Cost: 0

Total Project Cost: 2,663,432

LRTP: Page 3-9

TURNPIKE INTERCHANGE IMPROVEMENTS AT SW PORT ST LUCIE BLVD
4462201 SIS

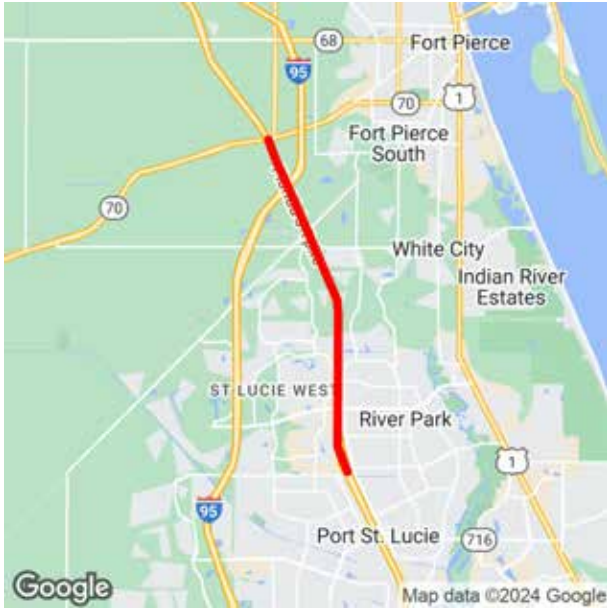

Project Description: INTERCHANGE IMPROVEMENT
Lead Agency: MANAGED BY FDOT **From:** INTERCHANGE
Length: 0.294 **To:** INTERCHANGE
Phase Group: PRELIMINARY ENGINEERING

Phase	Fund Code	2025	2026	2027	2028	2029	Total
PE	PKYI	4,302,271	0	0	0	0	4,302,271
		4,302,271					4,302,271

Prior Year Cost: 5,649
Future Year Cost: 0
Total Project Cost: 4,307,920
LRTP: Page 3-9

**TURNPIKE PORT ST. LUCIE SERVICE PLAZA
4497121 SIS**

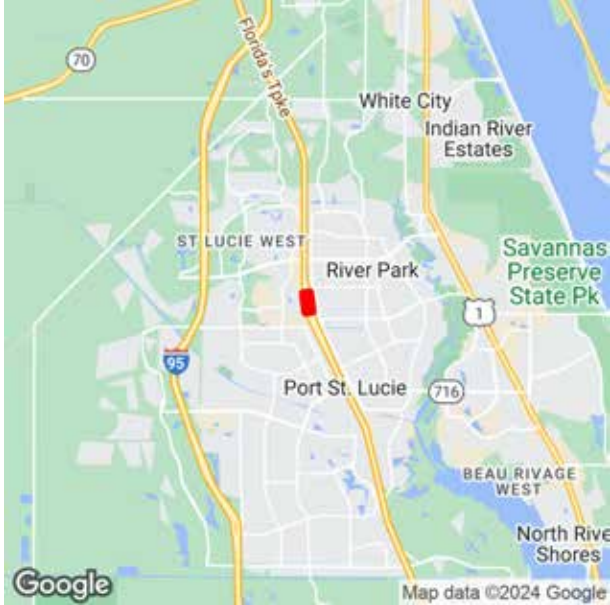

Project Description: REST AREA
Lead Agency: MANAGED BY FDOT
Length: 0.493
Phase Group: PRELIMINARY ENGINEERING

From:
To:

Phase	Fund Code	2025	2026	2027	2028	2029	Total
PE	PKYI	0	0	0	270,000	0	270,000
					270,000		270,000

Prior Year Cost: 1,500
Future Year Cost: 0
Total Project Cost: 271,500
LRTP: Page 3-9

TURNPIKE WIDEN FROM MARTIN C/L TO BECKER RD
4463341 SIS

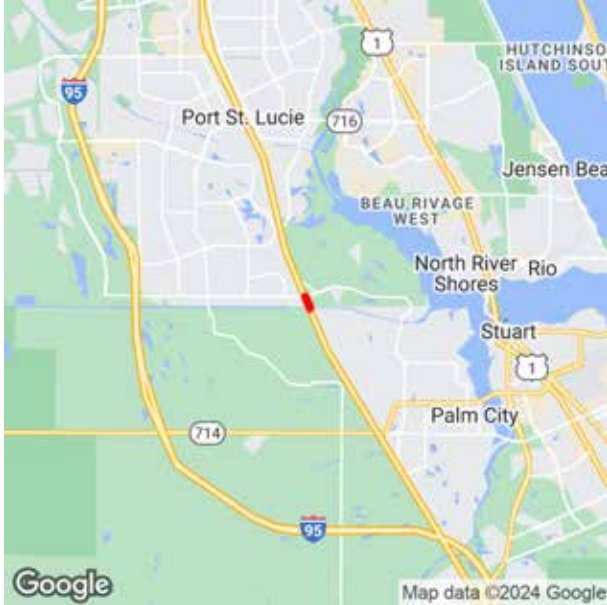

Project Description: ADD LANES & RECONSTRUCT
Lead Agency: MANAGED BY FDOT **From:** MARTIN C/L
Length: 0.404 **To:** BECKER RD
Phase Group: PRELIMINARY ENGINEERING, RIGHT OF WAY, CONSTRUCTION

Phase	Fund Code	2025	2026	2027	2028	2029	Total
PE	PKYI	2,500,000	0	0	0	0	2,500,000
		2,500,000					2,500,000

Prior Year Cost: 2,096,578
Future Year Cost: 83,685,498
Total Project Cost: 88,282,076
LRTP: Page 3-9

TURNPIKE WIDENING FROM CROSSTOWN PKWY TO SR70
4465831 SIS

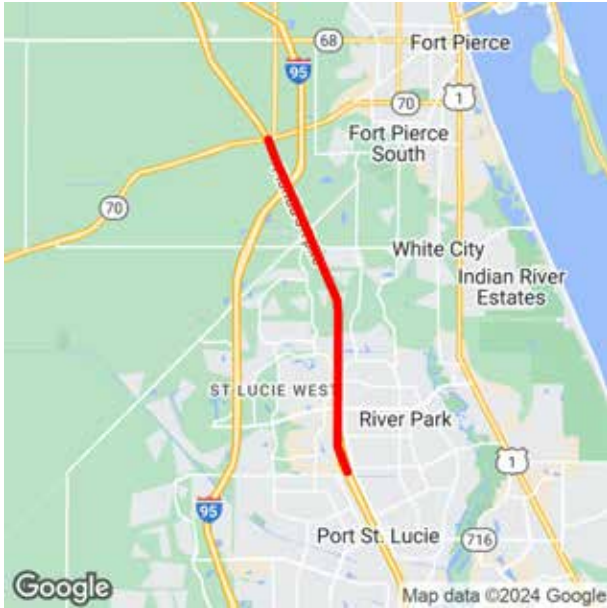

Project Description: ADD LANES & RECONSTRUCT
Lead Agency: MANAGED BY FDOT **From:** CROSSTOWN PKWY
Length: 8.412 **To:** SR70
Phase Group: PRELIMINARY ENGINEERING, RIGHT OF WAY

Phase	Fund Code	2025	2026	2027	2028	2029	Total
PE	PKYI	0	18,660,293	0	0	0	18,660,293
			18,660,293				18,660,293

Prior Year Cost: 864,449
Future Year Cost: 0
Total Project Cost: 19,524,742
LRTP: Page 3-9

TURNPIKE WIDENING FROM SW BECKER RD TO CROSTOWN PKWY

4463351 SIS

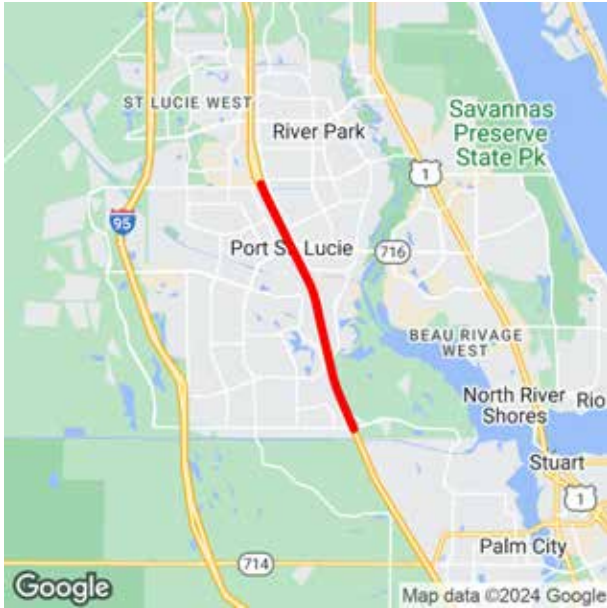

Project Description: ADD LANES & RECONSTRUCT

Lead Agency: MANAGED BY FDOT

From: CROSTOWN PKWY

Length: 6.227

To: SR70

Phase Group: PRELIMINARY ENGINEERING, RIGHT OF WAY

Phase	Fund Code	2025	2026	2027	2028	2029	Total
PE	PKYI	6,000,000	0	0	0	0	6,000,000
		6,000,000					6,000,000

Prior Year Cost: 5,212,678

Future Year Cost: 0

Total Project Cost: 11,212,678

LRTP: Page 3-9

D. LIST OF PRIORITY PROJECTS



Coco Vista Centre
 466 SW Port St. Lucie Boulevard, Suite 111
 Port St. Lucie, Florida 34953
 772-462-1593 www.stlucietpo.org

2023/24 List of Priority Projects (LOPP) (Adopted June 7, 2023)

Master List

2023/24 Priority Ranking	Major Gateway Corridor? ¹	Facility	Project Limits		Project Description	Project Status/Notes	In LRTP ² Cost Feasible Plan?	Estimated Cost	2022/23 Priority Ranking
			From	To					
1	N/A ³	St. Lucie TPO			Planning/administration as detailed in the Unified Planning Work Program		Yes	\$400,000	1
2	Yes	Midway Road	Glades Cut Off Road	Jenkins Road	Add 2 lanes, sidewalks, bicycle lanes	PE ⁴ underway, ROW ⁵ to start in FY 24/25	Yes	\$55,186,000 ⁶	2
3	Yes	Midway Road Turnpike Interchange Phase 2			New interchange with southbound off-ramp and northbound on-ramp		Yes	\$20,000,000 ⁷	4b
4	Yes	Kings Highway	Angle Road	Indrio Road	Add 2 lanes, sidewalks, bicycle lanes	PE underway, ROW to start in FY 23/24	Yes	\$142,162,000 ⁶	5
5	Yes	Northern/Airport Connector	Florida's Turnpike	Kings Highway	New multimodal corridor with interchanges at Florida's Turnpike and I-95		Yes	\$137,110,000 ⁸	6
6	Yes	Jenkins Road	Midway Road	Orange Avenue	Add 2 lanes to existing segments, construct 4 lanes for new segments, and add sidewalks and bicycle lanes	Initial PD&E ⁹ activities underway	Yes	\$51,890,000 ⁸	7
7	Yes	California Boulevard	Del Rio Boulevard	Crosstown Parkway	Add 2 lanes and shared-use paths		Yes	\$4,760,000 ⁸	NR ¹⁰

¹Landscape funding eligibility for capacity projects based on 2012 FDOT Landscape Policy
²LRTP: *SmartMoves 2045 Long Range Transportation Plan*, February 2021
³N/A: Not Applicable
⁴PE: Preliminary Engineering
⁵ROW: Right-of-Way Acquisition
⁶Source of Estimated Cost: Florida Department of Transportation District 4, June 2023
⁷Source of Estimated Cost: Strategic Intermodal System Cost Feasible Plan, May 2023
⁸Source of Estimated Cost: *SmartMoves 2045 Long Range Transportation Plan*, February 2021
⁹PD&E: Project Development and Environment Study
¹⁰NR: Not Ranked

Local Projects for Carbon Reduction Program (CRP) Funding and Transportation Alternatives Additional (TAA) Funding

Funding Source	Facility/Segment or Intersection	Project Limits		Project Description	Estimated Cost	Project Source ¹	LAP-Certified Implementing Agency	Project Status/Notes
		From	To					
CRP	Midway Road	US-1	Selvitz Road	Install fiber optic cable along Midway Road and traffic cameras/video detectors and adaptive signal control at the signalized intersections	\$370,000	CMP ² LOPP ³	St. Lucie County	
CRP	Gatlin Boulevard at Savona Boulevard			Extend eastbound and westbound left-turn lanes on Gatlin Boulevard	\$750,000	CMP LOPP	City of Port St. Lucie	Right-of-way acquisition is not needed
TAA	Green River Parkway Trail	Martin County Line	Walton Road	Resurfacing of multi-use path: 2.5 miles	\$350,000	TA ⁴ LOPP	City of Port St. Lucie	
TAA	St. James Drive	NE Lazy River Parkway	NE Royce Avenue	Sidewalk, 6-8 feet in width, 0.25 mile in length	\$419,000	CSAP ⁵	St. Lucie County	
TAA	Nebraska Avenue	South Lawnwood Circle	South 13th Street	Sidewalks, 6 feet in width, 1 mile in length, on both sides of street	\$717,000	City of Fort Pierce	City of Fort Pierce	Project-specific LAP Certification is necessary

¹Source of Estimated Cost is from the Project Source unless otherwise noted

²CMP: Congestion Management Process

³LOPP: List of Priority Projects

⁴TA: Transportation Alternatives

⁵CSAP: Comprehensive Safety Action Plan

Congestion Management Process (CMP) Projects

(The St. Lucie TPO's allocation of Surface Transportation Block Grant funds to CMP projects is \$300,000 - \$400,000 annually)

2023/24 Priority Ranking	Facility/Segment or Intersection	Project Description	Project Status/Notes	Estimated Cost ¹	Project Source	2022/23 Priority Ranking
1	St. Lucie Transportation Management Center (TMC)	Design, construction, and installation of equipment including communication servers, video displays, and workstations that was originally included in Phase 1 of the ATMS Master Plan ²	Phase I of the ATMS Master Plan was completed without a TMC	\$400,000	ATMS Master Plan	1
2	Orange Avenue and South 7th Street (ATMS Master Plan Phase 2A)	Install fiber optic cable along Orange Avenue from US-1 to Kings Highway and along South 7th Street from Orange Avenue to Avenue A and traffic cameras/video detectors and adaptive signal control at the signalized intersections	PE ⁴ to start in FY 2026/27	\$700,000	ATMS Master Plan	3
3	Midway Road (ATMS Master Plan Phase 2B)	Install fiber optic cable along Midway Road from US-1 to Selvitz Road and traffic cameras/video detectors and adaptive signal control at the signalized intersections		\$370,000	ATMS Master Plan	4
4	Gatlin Boulevard at Savona Boulevard	Extend eastbound and westbound left turn lanes on Gatlin Boulevard and install dedicated northbound and southbound right turn lanes on Savona Boulevard	Right-of-way acquisition is not anticipated to be needed	\$750,000 ⁵	CMP	5

¹Source of Estimated Cost is from the Project Source unless otherwise noted

²ATMS Master Plan: *Advanced Transportation Management System (ATMS) Master Plan for St. Lucie County*, February 2013

³CMP: *St. Lucie Transportation Planning Organization Congestion Management Process Major Update*, June 2018

⁴PE: Preliminary Engineering

⁵Source of Estimated Cost: City of Port St. Lucie

Transit Projects

2023/24 Priority Ranking	Facility/Equipment/Service	Project Location/Description	Is Funding for Capital and/or Operating?	In LRTP ¹ or TDP ² ?	Estimated Cost ³	2022/23 Priority Ranking
1	Port St. Lucie Intermodal Hub	Phase 1 completed in 2013 - Location is in need of an upgrade. Serves as connection point to four routes and Zone 1 Micro-Transit Service	Capital	Yes	\$4,500,000	NR ⁴
2	Vehicle Purchases	New/replacement buses as specified in the Transit Asset Management Plan ⁵	Capital	Yes	\$100,000-\$650,000	3
3	Micro-Transit Zone 1	Sustain service levels in the Tradition/Gatlin Boulevard area beyond expiration of the previous FDOT Service Development Grant	Capital & Operating	Yes	\$325,000-\$450,000 ⁶	4
4	Micro-Transit Fort Pierce	Expand on Freebee services in City of Fort Pierce and continue to provide transportation in transit deserts throughout the County	Capital & Operating	No	\$800,000	NR
5	Micro-Transit Zone 2	Expand the on-demand flex service to augment the fixed-route bus service with first and last mile connectivity to the Torino Boulevard area to sustain the existing service levels beyond the current FDOT Service Development Grant life of three years	Capital & Operating	Yes	\$325,000-\$450,000 ⁶	NR
6	Express Route Bus Service	Continue to link the Port St. Lucie and Fort Pierce Intermodal Hubs with a zone through a potential Service Development Grant	Capital & Operating	Yes	\$800,000	2
7	Bus Route Infrastructure	Miscellaneous locations along the fixed routes with priority at transfer locations	Capital	Yes	\$200,000 (total for bus shelters)	7
8	Expand Local Services	Improve frequency to 30 minutes on high performing routes	Operating	Yes	\$800,000	6
9	Transit Operations Center	Centralized operations and maintenance facility to serve the transit system fleet	Capital	Yes	\$18,000,000-\$20,000,000	1
10	Jobs Express Terminal Regional Service	Regional bus service to West Palm Beach with express commuter services	Operating	Yes	\$460,500 ⁶	5

¹LRTP: *SmartMoves 2045 Long Range Transportation Plan*, February 2021

²TDP: *Bus Plus, St. Lucie County FY 2020-FY 2029 Transit Development Plan Major Update*, June 2019

³Source of Estimated Cost: St. Lucie County Transit Staff, May 2023, unless otherwise noted

⁴NR: Not Ranked

⁵*Transit Asset Management Plan*, November 2020

⁶*Jobs Express Terminal Connectivity Study*, June 2020

Transportation Alternatives (TA) Projects

2023/24 Priority Ranking	Score ¹	Facility	Project Limits		Project Description	Project Source ²	Estimated Cost ²	2022/23 Priority Ranking
			From	To				
1	38.0	Peacock Trail	Gatlin Boulevard	Dreyfuss Boulevard	Shared-Use Path: 1.0 mile	2023 TA Grant Application ³	\$1,674,174 ⁴	11
2	25.5	Easy Street	US Highway 1	Silver Oak Drive	Sidewalk-1.0 miles		\$1,090,396 ⁶	2
3	50.0	Florida SUN Trail, Historic Fort Pierce Downtown Retrofit	Georgia Avenue	North State Route A1A	Bicycle Boulevard, Roadway Section Connections, and Railroad Crossing Improvements	TIP, Florida SUN Trail Grant, and St. Lucie WBN ⁵	TBD ⁷	3
4	42.5	Green River Parkway Trail	Martin County Line	Walton Road	Resurfacing of Shared-Use Path: 2.5 miles	City of Port St. Lucie, Florida SUN Trail, and St. Lucie WBN	\$350,000	Not Ranked
4	42.5	Oleander Avenue	Edwards Road	South Market Avenue	Sidewalk: 1.3 miles		\$1,500,000 ⁶	7
4	42.5	Oleander Avenue	Saeger Avenue	Beach Avenue	Sidewalk: 1.4 miles		\$1,650,000 ⁶	7
7	42.0	Lakehurst Drive	Bayshore Boulevard	Airoso Boulevard	Sidewalk: 1.3 miles	Under design by City of Port St. Lucie	\$825,000 ⁸	9
8	41.5	Indrio Road	U.S. Highway 1	Old Dixie Highway	Sidewalk: 0.2 miles		\$225,000 ⁶	12
9	40.5	Indrio Road	Kings Highway	U.S. Highway 1	Sidewalk: 2.6 miles		\$3,050,790 ⁶	17
10	40.0	Oleander Avenue	Midway Road	Saeger Avenue	Sidewalk: 1.5 miles		\$1,323,840	19
11	36.5	Angle Road	Kings Highway	North 53rd Street	Sidewalk: 1.3 miles		\$1,461,595 ⁶	12
12	36.0	17th Street	Georgia Avenue	Delaware Avenue	Sidewalk: 0.3 miles		\$74,268	13
12	36.0	Boston Avenue	25th Street	13th Street	Sidewalk: 0.8 miles		\$123,200	13
14	35.0	Abingdon Avenue	Import Drive	Savona Boulevard	Sidewalk: 0.9 miles	Under design by City of Port St. Lucie	\$575,000 ⁸	15
14	35.0	Brescia Street	Savage Boulevard	Gatlin Boulevard	Sidewalk: 1.3 miles		\$323,000 ⁸	15
16	33.5	Weatherbee Road	U.S. Highway 1	Oleander Avenue	Sidewalk: 0.5 miles		\$445,220	17
17	32.0	Range Line Road	Glades Cut Off Road	Martin County Line	Sidewalk: 6.1 miles		\$5,300,000 ⁶	18
17	32.0	West Midway Road	West of Glades Cut Off Road	Shinn Road Area	Sidewalk: 5.0 miles		\$5,753,580 ⁶	18
19	31.5	St. Lucie Boulevard	Kings Highway	North 25th Street	Sidewalk: 3.0 miles		\$2,600,000 ⁶	20
20	30.5	Sunrise Boulevard	Edwards Road	Midway Road	Sidewalk: 2.8 miles		\$2,250,000 ⁶	21
21	29.5	Bell Avenue	Oleander Avenue	Sunrise Boulevard	Sidewalk: 0.5 miles		\$411,836 ⁹	22

2023/24 Priority Ranking	Score ¹	Facility	Project Limits		Project Description	Project Source ²	Estimated Cost ²	2022/23 Priority Ranking
			From	To				
22	27.0	Old Dixie Highway	St. Lucie Boulevard	Turnpike Feeder Road	Sidewalk: 5.2 miles		\$6,066,780 ⁶	23
23	26.5	Glades Cut Off Road	Port St. Lucie City Boundary	Range Line Road	Sidewalk: 2.4 miles		\$2,830,390 ⁶	24
23	26.5	Keen Road	Angle Road	St. Lucie Boulevard	Sidewalk: 1.0 miles		\$1,160,000 ⁶	24
25	25.5	Selvitz Road	Edwards Road	South of Devine Road	Sidewalk: 1.8 miles		\$562,202	26
26	24.5	Juanita Avenue	North 53rd Street	North 41st Street	Sidewalk: 1.3 miles		\$393,004	27
27	15.5	Silver Oak Drive	Easy Street	East Midway Road	Sidewalk: 1.8 miles		\$2,076,392 ⁶	28
28	15.0	Taylor Dairy Road	Angle Road	St. Lucie Boulevard	Sidewalk: 1.0 miles		\$1,160,000 ⁶	29

¹Scores are based on the *St. Lucie TPO TA Project Prioritization Methodology*

²Project Source and Source of Estimated Cost: *SmartMoves 2045 Long Range Transportation Plan*, February 2021 (2045 LRTP), unless otherwise noted

³Project is anticipated to be programmed for construction in the FDOT FY 2024/25 - FY 2028/29 Work Program as a result of the 2023 TA Grant Cycle

⁴Source of Estimated Cost: 2023 TA Grant Application, March 2023

⁵WBN: Walk-Bike Network

⁶Source of Estimated Cost: St. Lucie County Engineering

⁷TBD: To be Determined

⁸Source of Estimated Cost: *City of Port St. Lucie Sidewalk Master Plan (Design and Construction)*, July 2017

⁹Source of Estimated Cost: 2019 TA Grant Application

E. PERFORMANCE MANAGEMENT

E.1 PERFORMANCE MANAGEMENT

Even before Federal legislation such as the Moving Ahead for Progress in the 21st Century Act (MAP-21) and the Fixing America's Surface Transportation (FAST) Act required Metropolitan Planning Organizations (MPOs) and State Departments of Transportation (DOTs) to implement transportation performance management, the St. Lucie TPO and the Florida Department of Transportation (FDOT) were using performance management to connect investment and policy decisions to help achieve performance goals. Performance measures are quantitative criteria used to evaluate progress toward meeting those goals, and performance measure targets are the benchmarks against which the data collected for the criteria are compared to evaluate the progress. Consistent with MAP-21 and the FAST Act, the St. Lucie TPO conducts performance-based planning, tracks performance measures, and establishes data-driven targets to evaluate the progress.

Performance-based planning ensures the most efficient investment of Federal transportation funds by increasing accountability, transparency, and providing for better investment decisions that focus on key outcomes related to the following seven national goals:

- Improving Safety;
- Maintaining Infrastructure Condition;
- Reducing Traffic Congestion;
- Improving the Efficiency of the System and Freight Movement;
- Protecting the Environment; and,
- Reducing Delays in Project Delivery.

According to MAP-21 and the FAST Act, State DOTs are required to establish Statewide performance targets, and MPOs have the option to support the Statewide targets or adopt their own targets. In addition to the Federally-required performance targets, the St. Lucie TPO has established targets for local performance measures in the SmartMoves 2045 Long Range Transportation Plan (LRTP) related to local goals. The performance targets adopted to date by the St. Lucie TPO and the FDOT are identified in the TIP/LRTP System Performance Report. The St. Lucie TPO recognizes the FDOT Highway Safety Improvement Program (HSIP) Implementation Plan 2022 which demonstrates Florida's progress toward meeting its annual safety performance targets as required by the Federal Highway Administration (FHWA).

The TIP reflects the investment priorities established by the St. Lucie TPO in the SmartMoves 2045 LRTP by including projects that support the goals and objectives of the SmartMoves 2045 LRTP. By using the prioritization and project selection process described in Section B.3, the TIP has the anticipated effect of contributing toward the progress in meeting the performance targets. For example, the TPO will make progress toward achieving the adopted performance targets of the Safety Performance Measures by selecting and supporting the implementation of projects which address safety issues such as sidewalk and bicycle lane construction and intersection improvements. Likewise, the TPO will make progress toward achieving performance targets upon adoption in the Florida Freight Mobility and Trade Plan, dated April 2020, by selecting and supporting freight projects in the TPO area which address freight issues such as freight bottlenecks. This anticipated effect and the progress toward meeting the performance targets are confirmed annually by the TIP/LRTP System Performance Report which also demonstrates the linking of the investment priorities to the targets.

The TIP/LRTP System Performance Report is presented as follows:

TIP/LRTP System Performance Report												
SmartMoves 2045 LRTP Goals	SmartMoves 2045 LRTP Objectives	SmartMoves 2045 and/or FAST Act Performance Measures	Federal Requirement	Data				FDOT Performance Target		County Target	St. Lucie TPO Performance Target	Progress Towards Meeting Target
				2020	2021	2022	2023	2 Year	4 Year			
SUPPORT ECONOMIC ACTIVITIES	Enable the efficient movement of people and goods on the roadway network	% of person miles traveled on the Interstate that are Reliable	✓	100% ⁽¹⁾	100% ⁽¹⁾	100% ⁽¹⁾	100% ⁽¹⁾	75%	70%		70%	+
		% of person miles traveled on the non Interstate NHS that are Reliable	✓	96.8% ⁽¹⁾	96.8% ⁽¹⁾	96.8% ⁽¹⁾	96% ⁽¹⁾	50%	50%		50%	+
		The Travel Time Reliability (TTTR) index - the average of the maximum TTTR calculated for each reporting segment on the Interstate	✓	1.10 ⁽¹⁾	1.11 ⁽¹⁾	1.11 ⁽¹⁾	1.14 ⁽¹⁾	1.75	2		2	+
	Optimize the management and operations of the transportation system	TSM&O Strategic Network / ATMS Network Deployment		34% ⁽²⁾	34% ⁽²⁾	35.8% ⁽²⁾	37.2% ⁽²⁾				100%	+
	Maximize the efficiency and effectiveness of the current transit system and improve access to destinations that support economic growth	% population within ¼ mile of Major Activity Centers (MACs)		10.9% ⁽³⁾	10.9% ⁽³⁾	11.5% ⁽³⁾	12.1% ⁽³⁾				16%	+
	Transit routes providing access to MACs			8 ⁽⁴⁾	8 ⁽⁴⁾	8 ⁽⁴⁾	8 ⁽⁴⁾				10	+
PROVIDE TRAVEL CHOICES	Encourage walking, cycling, and other micromobility options	% of roadways with sidewalks and bike lanes		29% ⁽²⁾	30% ⁽²⁾	30.5% ⁽²⁾	31.2% ⁽²⁾				43%	+
	Improve transit accessibility	% of transit stops with sidewalk access		90% ⁽²⁾	90% ⁽²⁾	90% ⁽²⁾	91% ⁽²⁾				100%	+
		Miles of fixed route transit service		206 ⁽⁴⁾	206 ⁽⁴⁾	206 ⁽⁴⁾	206 ⁽⁴⁾				300	+
MAINTAIN THE TRANSPORTATION SYSTEM	Maintain condition of existing transportation assets	% of Interstate pavement in good condition	✓	82.3% ⁽¹⁾	84% ⁽¹⁾	89.4% ⁽¹⁾	coming soon	60%	60%		60%	+
		% of Interstate pavement in poor condition	✓	0% ⁽¹⁾	0% ⁽¹⁾	0% ⁽¹⁾	coming soon	5%	5%		5%	+
		% of non-Interstate National Highway System pavement in good condition	✓	n/a	48.6% ⁽¹⁾	51.3% ⁽¹⁾	coming soon	40%	40%		40%	+
		% of non-Interstate National Highway System pavement in poor condition	✓	n/a	1.1% ⁽¹⁾	1.1% ⁽¹⁾	coming soon	5%	5%		5%	+
		% of National Highway System bridges classified as in good condition	✓	83.4% ⁽¹⁾	83.6% ⁽¹⁾	75.3% ⁽¹⁾	coming soon	50%	50%		50%	+
		% of National Highway System bridges classified as in poor condition	✓	0% ⁽¹⁾	0% ⁽¹⁾	0% ⁽¹⁾	coming soon	10%	10%		10%	+
	Maintain condition of existing transit assets	Equipment - % of non-revenue, support-service and maintenance vehicles that have met or exceeded their useful life benchmark	✓	57% ⁽⁴⁾	57% ⁽⁴⁾	57% ⁽⁴⁾	57% ⁽⁴⁾			71%	0%	+
		Rolling Stock - % of revenue vehicles within a particular asset class that have either met or exceeded their useful life benchmark (fixed route)	✓	0% ⁽⁴⁾	0% ⁽⁴⁾	61% ⁽⁴⁾	69% ⁽⁴⁾			36%	0%	
		% of facilities with a condition rating below 3.0 on the FTA Transit Economic Requirements Model (TERM) Scale	✓	4.5% ⁽⁴⁾	4.5% ⁽⁴⁾	4.5% ⁽⁴⁾	4.3% ⁽⁴⁾			4.1%	0%	
PROVIDE EQUITABLE, AFFORDABLE, AND SUSTAINABLE URBAN MOBILITY	Support healthy living strategies, programs, and improvements to create more livable communities	Walking modal share		1.9% ⁽³⁾	1.4% ⁽³⁾	1.3% ⁽³⁾	coming soon				Maintain or Increase	
		Bike modal share		0.3% ⁽³⁾	0.3% ⁽³⁾	0.4% ⁽³⁾	coming soon				Maintain or Increase	+
		Transit modal share		0.4% ⁽³⁾	0.3% ⁽³⁾	0.2% ⁽³⁾	coming soon				Maintain or Increase	
	Ensure community participation is representative	Opportunities for engagement in traditionally underserved areas		7 ⁽²⁾	7 ⁽²⁾	7 ⁽²⁾	7 ⁽²⁾				Maintain or Increase	+
	Provide for transportation needs of transportation disadvantaged	% of low income, older adults, persons with disabilities within ¼ mile of transit route		27.1% ⁽³⁾	27.3% ⁽³⁾	27.9% ⁽³⁾	coming soon				30%	+
	Make transportation investments that minimize impacts to natural environment and allocate resources toward mitigation	Number of additional roadway lane miles of impacting environmentally sensitive areas		0 ⁽²⁾	0 ⁽²⁾	0 ⁽²⁾	0 ⁽²⁾				0	+
	Improve transportation system's stability/resiliency in event of climate change, emergencies, or disasters	% of roadway lane miles subject to climate change impacts		0% ⁽⁵⁾	0% ⁽⁵⁾	0% ⁽⁵⁾	0% ⁽⁵⁾				0%	+
IMPROVE SAFETY AND SECURITY	Improve safety and security in the Highway System	Number of fatalities	✓	41 ⁽⁶⁾	44 ⁽⁶⁾	44 ⁽⁶⁾	coming soon	0	0		38/0 ⁽⁷⁾	
		Fatality rate per 100 million vehicle miles traveled	✓	1.18 ⁽⁶⁾	1.25 ⁽⁶⁾	1.24 ⁽⁶⁾	coming soon	0	0		1.09/0 ⁽⁷⁾	+
		Number of serious injuries	✓	145 ⁽⁶⁾	148 ⁽⁶⁾	147 ⁽⁶⁾	coming soon	0	0		148/0 ⁽⁷⁾	+
		Serious injury rate per 100 million vehicle miles traveled	✓	4.21 ⁽⁶⁾	4.23 ⁽⁶⁾	4.12 ⁽⁶⁾	coming soon	0	0		4.04/0 ⁽⁷⁾	+
	Improve safety and security in the Non-Motorized System	Number of non-motorized fatalities and serious injuries combined	✓	28 ⁽⁶⁾	32 ⁽⁶⁾	31 ⁽⁶⁾	coming soon	0	0		26/0 ⁽⁷⁾	+
	Improve safety and security in the Transit System	Total number of reportable fatalities (fixed route)	✓	0 ⁽⁴⁾	0 ⁽⁴⁾	0 ⁽⁴⁾	0 ⁽⁴⁾			0	SupportCounty Target	+
		Rate of reportable fatalities per total vehicle revenue miles by mode (fixed route)	✓	0 ⁽⁴⁾	0 ⁽⁴⁾	0 ⁽⁴⁾	0 ⁽⁴⁾			0	SupportCounty Target	+
		Total number of reportable injuries (fixed route)	✓	0 ⁽⁴⁾	3 ⁽⁴⁾	2 ⁽⁴⁾	2 ⁽⁴⁾			1	SupportCounty Target	
		Rate of reportable injuries per total vehicle revenue miles by mode (fixed route)	✓	0 ⁽⁴⁾	0.51 ⁽⁴⁾	0.38 ⁽⁴⁾	0.16 ⁽⁴⁾			0.14	SupportCounty Target	+
		Total number of reportable safety events (fixed route)	✓	0 ⁽⁴⁾	3 ⁽⁴⁾	1 ⁽⁴⁾	0 ⁽⁴⁾			0	SupportCounty Target	+
Rate of reportable safety events per total vehicle revenue miles by mode (fixed route)		✓	0 ⁽⁴⁾	0.51 ⁽⁴⁾	0.18 ⁽⁴⁾	0 ⁽⁴⁾			0	SupportCounty Target	+	
Mean distance between major mechanical failures by mode (fixed route)	✓	10,410 ⁽⁴⁾	9,639 ⁽⁴⁾	6,613 ⁽⁴⁾	9,509 ⁽⁴⁾			10,460	SupportCounty Target	+		

1- FDOT Data; 2 - St. Lucie TPO; 3- ACS 5-year estimates; 4 - St. Lucie County Community Service Department Transit Division; 5 - Results from Florida Sea Level Scenario Sketch Planning Tool, based on NOAA High projections in 2040; 6 - FDOT 5-year rolling average; 7 - Interim Benchmark/Target.

The following graphic further demonstrates how the TIP reflects the investment priorities established in the SmartMoves 2045 LRTP and how those investment priorities are linked to the performance targets in the TIP:

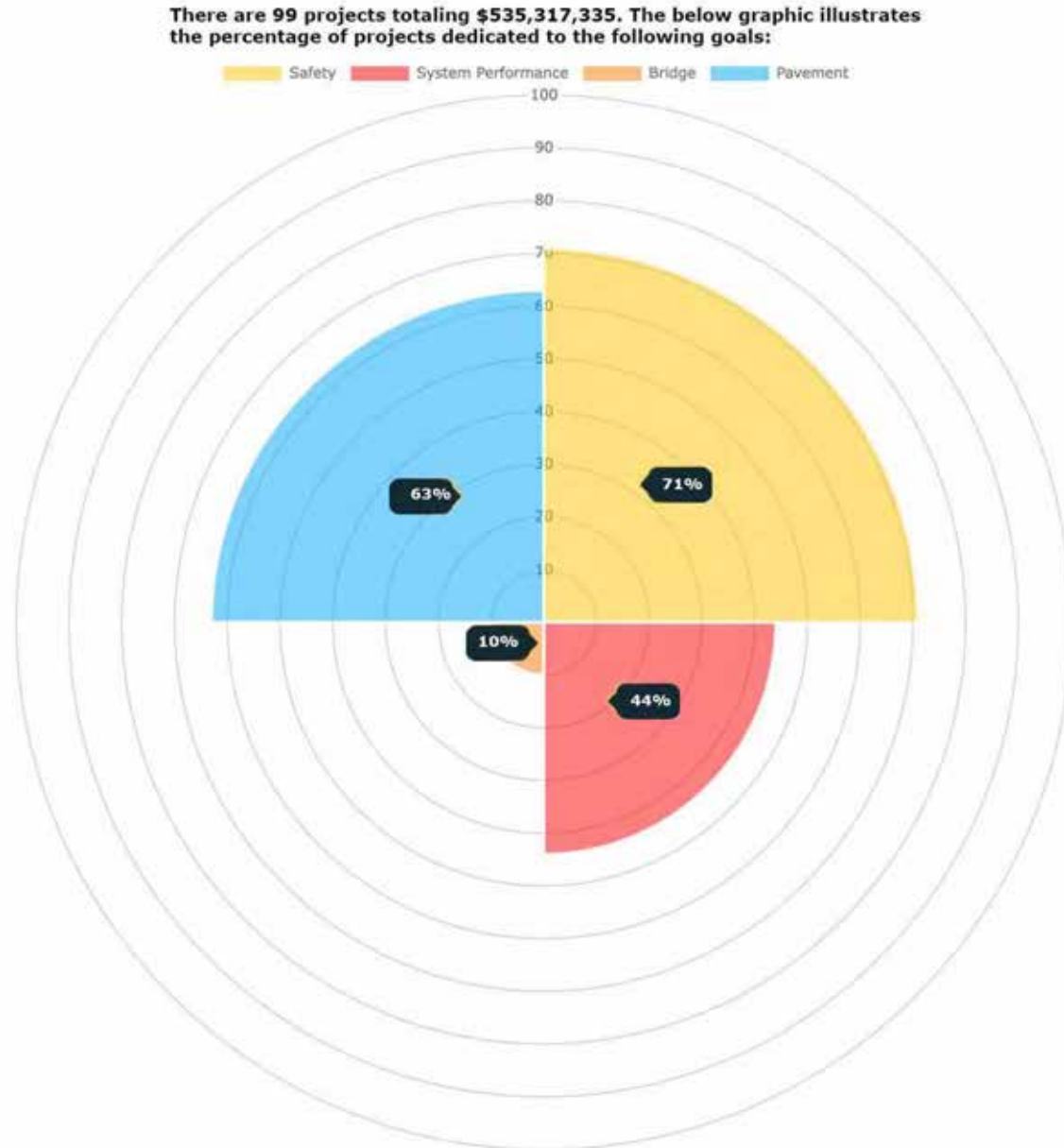

E.2 ASSET MANAGEMENT

MAP-21 and the FAST Act require transit providers to adopt performance targets for transit asset management, also known as “State of Good Repair” targets, in cooperation with the MPOs. The performance targets adopted to date by the St. Lucie TPO and St. Lucie County, which is the local transit provider, are identified in the TIP/LRTP System Performance Report.

In addition, MAP-21 and the FAST Act require the development of a risk-based TAMP for all pavement and bridges on the National Highway System. The most recent Florida Transportation Asset Management Plan (TAMP) was completed by FDOT on December 30, 2022. The TAMP will serve as the basis for establishing in future TIPs the targets for the pavement and bridge condition performance measures identified in the TIP/LRTP System Performance Report. The TPO will make progress toward achieving performance targets upon adoption in the TAMP by selecting and supporting asset management projects in the TPO area which address asset management issues such as pavement resurfacing and bridge replacement projects.

The St. Lucie TPO will continue to coordinate with St. Lucie County and FDOT to establish performance targets and meet the other requirements of the Federal performance management process.

E.3 FLORIDA TRANSPORTATION PERFORMANCE MEASURES CONSENSUS PLANNING DOCUMENT

In accordance with 23 CFR 450.314(h), the St. Lucie TPO, FDOT, and St. Lucie County (as the provider of public transportation) have agreed upon and developed specific written provisions for cooperatively developing and sharing information related to transportation performance data, the selection of performance targets, the reporting of performance targets, the reporting of performance to be used in tracking progress toward attainment of critical outcomes for the St. Lucie TPO area, and the collection of data for FDOT's asset management plan for the National Highway System. These provisions are documented as follows:

Purpose and Authority

This document has been cooperatively developed by the FDOT and Florida's 27 Metropolitan Planning Organizations (MPOs) through the Florida Metropolitan Planning Organization Advisory Council (MPOAC), and, by representation on the MPO boards and committees, the providers of public transportation in the MPO planning areas.

The purpose of the document is to outline the minimum roles of FDOT, the MPOs, and the providers of public transportation in the MPO planning areas to ensure consistency to the maximum extent practicable in satisfying the transportation performance management requirements promulgated by the United States Department of Transportation in Title 23 Parts 450, 490, 625, and 673 of the *Code of Federal Regulations* (23 CFR). Specifically:

- 23 CFR 450.314(h)(1) requires that "The MPO(s), State(s), and providers of public transportation shall jointly agree upon and develop specific written procedures for cooperatively developing and sharing information related to transportation performance data, the selection of performance targets, the reporting of performance targets, the reporting of performance to be used in tracking progress toward achievement of critical outcomes for the region of the MPO, and the collection of data for the State asset management plan for the National Highway System (NHS)."
- 23 CFR 450.314(h)(2) allows for these provisions to be "Documented in some other means outside the metropolitan planning agreements as determined cooperatively by the MPO(s), State(s), and providers of public transportation."

Section 339.175(11), Florida Statutes creates the MPOAC to "Assist MPOs in carrying out the urbanized area transportation planning process by serving as the principal forum for collective policy discussion pursuant to law" and to "Serve as a clearinghouse for review and comment by MPOs on the Florida Transportation Plan and on other issues required to comply with federal or state law in carrying out the urbanized transportation planning processes." The MPOAC Governing Board membership includes one representative of each MPO in Florida.

This document was developed, adopted, and subsequently updated by joint agreement of the FDOT Secretary and the MPOAC Governing Board. Each MPO will adopt this document by incorporation in its annual Transportation Improvement Program (TIP) or by separate board action as documented in a resolution or meeting minutes, which will serve as documentation of agreement by the MPO and the provider(s) of public transportation in the MPO planning area to carry out their roles and responsibilities as described in this general document.

Roles and Responsibilities

This document describes the general processes through which FDOT, the MPOs, and the providers of public transportation in MPO planning areas will cooperatively develop and share information related to transportation performance management.

Email communications will be considered written notice for all portions of this document. Communication with FDOT related to transportation performance management generally will occur through the Administrator for Metropolitan Planning in the Office of Policy Planning. Communications with the MPOAC related to transportation performance management generally will occur through the Executive Director of the MPOAC.

1. Transportation performance data:

- a) FDOT will collect and maintain data, perform calculations of performance metrics and measures, and provide to each MPO the results of the calculations used to develop statewide targets for all applicable federally required performance measures. FDOT also will provide to each MPO the results of calculations for each applicable performance measure for the MPO planning area, and the county or counties included in the MPO planning area. FDOT and the MPOAC agree to use the National Performance Management Research Data Set as the source of travel time data and the defined reporting segments of the Interstate System and non-Interstate National Highway System for the purposes of calculating the travel time-based measures specified in 23 CFR 490.507, 490.607, and 490.707, as applicable.
- b) Each MPO will share with FDOT any locally generated data that pertains to the federally required performance measures, if applicable, such as any supplemental data the MPO uses to develop its own targets for any measure.
- c) Each provider of public transportation is responsible for collecting performance data in the MPO planning area for the transit asset management measures as specified in 49 CFR 625.43 and the public transportation safety measures as specified in the National Public Transportation Safety Plan. The providers of public transportation will provide to FDOT and the appropriate MPO(s) the transit performance data used to support these measures.

2. Selection of performance targets:

FDOT, the MPOs, and providers of public transportation will select their respective performance targets in coordination with one another. Selecting targets generally refers to the processes used to identify, evaluate, and make decisions about potential targets prior to action to formally establish the targets. Coordination will include as many of the following opportunities as deemed appropriate for each measure: in-person meetings, webinars, conferences calls, and email/written communication. Coordination will include timely sharing of information on proposed targets and opportunities to provide comment prior to establishing final comments for each measure.

The primary forum for coordination between FDOT and the MPOs on selecting performance targets and related policy issues is the regular meetings of the MPOAC. The primary forum for coordination between MPOs and providers of public transportation on selecting transit performance targets is the TIP development process.

Once targets are selected, each agency will take action to formally establish the targets in its area of responsibility.

- a) FDOT will select and establish a statewide target for each applicable federally required performance measure.
 - i. To the maximum extent practicable, FDOT will share proposed statewide targets at the MPOAC meeting scheduled in the calendar quarter prior to the dates required for establishing the target under federal rule. FDOT will work through the MPOAC to provide email communication on the proposed targets to the MPOs not in attendance at this meeting. The MPOAC as a whole, and individual MPOs as appropriate, will provide comments to FDOT on the proposed statewide targets within sixty (60) days of the MPOAC meeting. FDOT will provide an update to the MPOAC at its subsequent meeting on the final proposed targets, how the comments received from the MPOAC and any individual MPOs were considered, and the anticipated date when FDOT will establish final targets.
 - ii. FDOT will provide written notice to the MPOAC and individual MPOs within two (2) business days of when FDOT establishes final targets. This notice will provide the relevant targets and the date FDOT established the targets, which will begin the 180-day time-period during which each MPO must establish the corresponding performance targets for its planning area.
 - b) Each MPO will select and establish a target for each applicable federally required performance measure. To the extent practicable, MPOs will propose, seek comment on, and establish their targets through existing processes such as the annual TIP update. For each performance measure, an MPO will have the option of either:
 - i. Choosing to support the statewide target established by FDOT, and providing documentation (typically in the form of meeting minutes, a letter, a resolution, or incorporation in a document such as the TIP) to FDOT that the MPO agrees to plan and program projects so that they contribute toward the accomplishments of FDOT's statewide targets for that performance measure.
 - ii. Choosing to establish its own target, using a quantifiable methodology for its MPO planning area. If the MPO chooses to establish its own target, the MPO will coordinate with FDOT and, as applicable, providers of public transportation regarding the approach used to develop the target and the proposed target prior establishment of a final target. The MPO will provide FDOT and, as applicable, providers of public transportation, documentation (typically in the form of meeting minutes, a letter, a resolution, or incorporation in a document such as the TIP) that includes the final targets and the date when the targets were established.
 - c) The providers of public transportation in MPO planning areas will select and establish performance targets annually to meet the federal performance management requirements for transit asset management and transit safety under 49 U.S.C. 5326(c) and 49 U.S.C. 5329(d).
 - i. The Tier I providers of public transportation will establish performance targets to meet the federal performance management requirements for transit asset management. Each Tier I provider will provide written notice to the appropriate MPO and FDOT when it establishes targets. This notice will provide the final targets and the date when the targets were established, which will begin the 180-day period within which the MPO must establish its transit-related performance targets. MPOs may choose
-

to update their targets when the Tier I provider(s) updates theirs, or when the MPO amends its long-range transportation plan by extending the horizon year in accordance with 23 CFR 450.324(c).

- ii. FDOT is the sponsor of a Group Transit Asset Management plan for subrecipients of Section 5311 and 5310 grant funds. The Tier II providers of public transportation may choose to participate in FDOT's group plan or to establish their own targets. FDOT will notify MPOs and those participating Tier II providers following of establishment of transit-related targets. Each Tier II provider will provide written notice to the appropriate MPO and FDOT when it establishes targets. This notice will provide the final targets and the date the final targets were established, which will begin the 180-day period within which the MPO must establish its transit-related performance targets. MPOs may choose to update their targets when the Tier II provider(s) updates theirs, or when the MPO amends its long-range transportation plan by extending the horizon year in accordance with 23 CFR 450.324(c).
- iii. FDOT will draft and certify a Public Transportation Agency Safety Plan for any small public transportation providers (defined as those who are recipients or subrecipients of federal financial assistance under 49 U.S.C. 5307, have one hundred (100) or fewer vehicles in peak revenue service, and do not operate a rail fixed guideway public transportation system). FDOT will coordinate with small public transportation providers on selecting statewide public transportation safety performance targets, with the exception of any small operator that notifies FDOT that it will draft its own plan.
- iv. All other public transportation service providers that receive funding under 49 U.S. Code Chapter 53 (excluding sole recipients of sections 5310 and/or 5311 funds) will provide written notice to the appropriate MPO and FDOT when they establish public transportation safety performance targets. This notice will provide the final targets and the date the final targets were established, which will begin the 180-day period within which the MPO must establish its transit safety performance targets. MPOs may choose to update their targets when the provider(s) updates theirs, or when the MPO amends its long-range transportation plan by extending the horizon year in accordance with 23 CFR 450.324(c).
- v. If the MPO chooses to support the asset management and safety targets established by the provider of public transportation, the MPO will provide to FDOT and the provider of public transportation documentation that the MPO agrees to plan and program MPO projects so that they contribute toward achievement of the statewide or public transportation provider targets. If the MPO chooses to establish its own targets, the MPO will develop the target in coordination with FDOT and the providers of public transportation. The MPO will provide FDOT and the providers of public transportation documentation (typically in the form of meeting minutes, a letter, a resolution, or incorporation in a document such as the TIP) that includes the final targets and the date the final targets were established. In cases where two or more providers operate in an MPO planning area and establish different targets for a given measure, the MPO has the options of coordinating with the providers to establish a single target for the MPO planning area, or establishing a set of targets for the MPO planning area.

3. Reporting performance targets:

- a) Reporting targets generally refers to the process used to report targets, progress achieved in meeting targets, and the linkage between targets and decision making processes FDOT will report its final statewide performance targets to the Federal Highway Administration (FHWA) and the Federal Transit Administration (FTA) as mandated by the federal requirements.
-

- i. FDOT will include in future updates or amendments of the statewide long-range transportation plan a description of all applicable performance measures and targets and a system performance report, including progress achieved in meeting the performance targets, in accordance with 23 CFR 450.216(f).
 - ii. FDOT will include in future updates or amendments of the statewide transportation improvement program a discussion of the anticipated effect of the program toward achieving the state's performance targets, linking investment priorities to those performance targets, in accordance with 23 CFR 450.218 (q).
 - iii. FDOT will report targets and performance data for each applicable highway performance measure to FHWA, in accordance with the reporting timelines and requirements established by 23 CFR 490; and for each applicable public transit measure to FTA, in accordance with the reporting timelines and requirements established by 49 CFR 625 and 40 CFR 673.
 - b) Each MPO will report its final performance targets as mandated by federal requirements to FDOT. To the extent practicable, MPOs will report final targets through the TIP update or other existing documents.
 - i. Each MPO will include in future updates or amendments of its metropolitan long-range transportation plan a description of all applicable performance measures and targets and a system performance report, including progress achieved by the MPO in meeting the performance targets, in accordance with 23 CFR 450.324(f)(3-4).
 - ii. Each MPO will include in future updates or amendments of its TIP a discussion of the anticipated effect of the TIP toward achieving the applicable performance targets, linking investment priorities to those performance targets, in accordance with 23 CFR 450.326(d).
 - iii. Each MPO will report target-related status information to FDOT upon request to support FDOT's reporting requirements to FHWA.
 - c) Providers of public transportation in MPO planning areas will report all established transit asset management targets to the FTA National Transit Database (NTD) consistent with FTA's deadlines based upon the provider's fiscal year and in accordance with 49 CFR Parts 625 and 630, and 49 CFR Part 673.
 4. Reporting performance to be used in tracking progress toward attainment of performance targets for the MPO planning area:
 - a) FDOT will report to FHWA or FTA as designated, and share with each MPO and provider of public transportation, transportation performance for the state showing the progress being made towards attainment of each target established by FDOT, in a format to be mutually agreed upon by FDOT and the MPOAC.
 - b) If an MPO establishes its own targets, the MPO will report to FDOT on an annual basis transportation performance for the MPO area showing the progress being made towards attainment of each target established by the MPO, in a format to be mutually agreed upon by FDOT and the MPOAC. To the extent practicable, MPOs will report progress through existing processes including, but not limited to, the annual TIP update.
-

- c) Each provider of public transportation will report transit performance annually to the MPO(s) covering the provider's service area, showing the progress made toward attainment of each target established by the provider.
5. Collection of data for the State asset management plans for the National Highway System (NHS):
- a) FDOT will be responsible for collecting bridge and pavement condition data for the State asset management plan for the NHS. This includes NHS roads that are not on the State highway system but instead are under the ownership of local jurisdictions, if such roads exist.
-



AGENDA ITEM SUMMARY

Board/Committee:	Technical Advisory Committee (TAC)
Meeting Date:	May 21, 2024
Item Number:	6b
Item Title:	2024/25 List of Priority Projects (LOPP)
Item Origination:	Unified Planning Work Program (UPWP)
UPWP Reference:	Task 3.3 – Transportation Improvement Program
Requested Action:	Recommend adoption of the draft 2024/25 LOPP, recommend adoption with conditions, or do not recommend adoption.
Staff Recommendation:	Based on the consistency of the projects in the draft 2024/25 LOPP with the SmartMoves 2045 Long Range Transportation Plan and the prioritization of the projects in accordance with the TPO's adopted prioritization methodologies, it is recommended that the draft 2024/25 LOPP be recommended for adoption by the TPO Board.

Attachments

- Staff Report
- Draft 2024/25 LOPP
- 2023/24 LOPP



Coco Vista Centre
 466 SW Port St. Lucie Blvd, Suite 111
 Port St. Lucie, Florida 34953
 772-462-1593 www.stlucietpo.org

MEMORANDUM

TO: Technical Advisory Committee (TAC)

FROM: Peter Buchwald
 Executive Director

DATE: May 15, 2024

SUBJECT: 2024/25 List of Priority Projects (LOPP)

BACKGROUND

As part of the annual development of the St. Lucie TPO's Transportation Improvement Program (TIP), the LOPP is developed for submittal to the Florida Department of Transportation District 4 (FDOT) for the allocation of funding to projects that are or will be programmed in the TIP. The projects identified in the LOPP subsequently are funded and included in the FDOT Work Program to the maximum extent feasible. The St. Lucie TPO's TIP for FY 2025/26 – FY 2029/30 then will be developed based on the LOPP and the FDOT Work Program. The LOPP is required to be submitted to FDOT by August 1st, and the TPO Advisory Committees are requested to review it, provide input, and develop recommendations for the TPO Board regarding its adoption.

ANALYSIS

The draft 2024/25 LOPP is attached. The revisions from the 2023/24 LOPP, also attached, are summarized in the following.

Master List: The Midway Road Widening Project from Glades Cut Off Road to Jenkins Road was removed because it is programmed for construction in FY 2026/27. The Northern/Airport Connector Project was moved to the bottom of the list because the feasibility of the Northern Connector portion of the project is questioned by the developer of the project and Florida's Turnpike. Funding for the St. Lucie TPO was increased to \$600,000 for inflation and growth. The Project Status/Notes were updated based on the FY 2024/25 – FY 2028/29 TIP, and the Estimated Costs are being updated based on the latest information.

Local Projects for Carbon Reduction Program (CRP) Funding and Transportation Alternatives Additional (TAA) Funding: This list was deleted because all of the projects were programmed, and all of the program funding available to the St. Lucie TPO was allocated.

Congestion Management Process (CMP) Projects: The Midway Road Fiber Optic Project and Gatlin Boulevard at Savona Boulevard Intersection Improvement project were removed because they are programmed for construction.

Transit Projects: This list was revised based on input from Area Regional Transit with the most significant revisions being the additions of the Micro-Transit Zone 3 to service the Western Fort Pierce Area and Van Pool Service for St. Lucie County residents to access jobs in St. Lucie County.

Transportation Alternatives (TA) Projects: This list was updated to reflect the results of the 2024 TA grant cycle which prioritized the Sunrise Boulevard Sidewalk Project and to remove the Peacock Trail Project because it is programmed for construction in the FY 2024/25 – FY 2028/29 TIP.

The projects in the draft 2024/25 LOPP are consistent with the SmartMoves 2045 Long Range Transportation Plan (LRTP) and are prioritized, where applicable, in accordance with the prioritization methodologies adopted by the St. Lucie TPO.

RECOMMENDATION

Based on the consistency of the projects in the draft 2024/25 LOPP with the SmartMoves 2045 LRTP and the prioritization of the projects in accordance with the TPO's adopted prioritization methodologies, it is recommended that the draft 2024/25 LOPP be recommended for adoption by the TPO Board.

DRAFT

2024/25 List of Priority Projects (LOPP)
 (Adopted _____)

Master List

2024/25 Priority Ranking	Major Gateway Corridor? ¹	Facility	Project Limits		Project Description	Project Status/Notes	In LRTP ² Cost Feasible Plan?	Estimated Cost	2023/24 Priority Ranking
			From	To					
1	N/A ³	St. Lucie TPO			Planning/administration as detailed in the Unified Planning Work Program		Yes	\$600,000	1
2	Yes	Midway Road Turnpike Interchange Phase 2			New interchange with southbound off-ramp and northbound on-ramp		Yes	\$20,000,000 ⁴	3
3	Yes	Kings Highway	Angle Road	Indrio Road	Add 2 lanes, sidewalks, bicycle lanes	ROW ⁵ acquisition underway	Yes	\$142,162,000 ⁶	4
4	Yes	Jenkins Road	Midway Road	Orange Avenue	Add 2 lanes to existing segments, construct 4 lanes for new segments, and add sidewalks and bicycle lanes	PD&E ⁷ underway	Yes	\$51,890,000 ⁸	6
5	Yes	California Boulevard	Del Rio Boulevard	Crosstown Parkway	Add 2 lanes and shared-use paths		Yes	\$4,760,000 ⁸	7
6 ⁹	Yes	St. Lucie West Boulevard	Peacock Boulevard	Cashmere Boulevard	Add 2 lanes and multimodal paths	City to complete design	Yes	\$22,000,000	8
7	Yes	Northern/Airport Connector	Florida's Turnpike	Kings Highway	New multimodal corridor with interchanges at Florida's Turnpike and I-95		Yes	\$137,110,000 ⁸	5

¹Landscape funding eligibility for capacity projects based on 2012 FDOT Landscape Policy
²LRTP: *SmartMoves 2045 Long Range Transportation Plan*, February 2021
³N/A: Not Applicable
⁴Source of Estimated Cost: Strategic Intermodal System Cost Feasible Plan, May 2023
⁵ROW: Right-of-Way Acquisition
⁶Source of Estimated Cost: Florida Department of Transportation District 4, June 2023
⁷PD&E: Project Development and Environment Study
⁸Source of Estimated Cost: *SmartMoves 2045 Long Range Transportation Plan*, February 2021
⁹For Transportation Regional Incentive Program (TRIP) Grant Funding Only

Congestion Management Process (CMP) Projects

(The St. Lucie TPO's allocation of Surface Transportation Block Grant funds to CMP projects is \$300,000 - \$400,000 annually)

2024/25 Priority Ranking	Facility/Segment or Intersection	Project Description	Project Status/Notes	Estimated Cost ¹	Project Source	2023/24 Priority Ranking
1	St. Lucie Transportation Management Center (TMC)	Design, construction, and installation of equipment including communication servers, video displays, and workstations that was originally included in Phase 1 of the ATMS Master Plan ²	Phase I of the ATMS Master Plan was completed without a TMC	\$400,000	ATMS Master Plan	1
2	Orange Avenue and South 7th Street (ATMS Master Plan Phase 2A)	Install fiber optic cable along Orange Avenue from US-1 to Kings Highway and along South 7th Street from Orange Avenue to Avenue A and traffic cameras/video detectors and adaptive signal control at the signalized intersections	PE ⁴ to start in FY 2026/27	\$700,000	ATMS Master Plan	2

¹Source of Estimated Cost is from the Project Source unless otherwise noted

²ATMS Master Plan: *Advanced Transportation Management System (ATMS) Master Plan for St. Lucie County*, February 2013

³CMP: *St. Lucie Transportation Planning Organization Congestion Management Process Major Update*, June 2018

⁴PE: Preliminary Engineering

⁵Source of Estimated Cost: City of Port St. Lucie

Transit Projects

2024/25 Priority Ranking	Facility/Equipment/Service	Project Location/Description	Is Funding for Capital and/or Operating?	In LRTP ¹ or TDP ² ?	Estimated Cost ³	2023/24 Priority Ranking
1	Port St. Lucie Intermodal Hub	Phase 1 completed in 2013 - Location is in need of an upgrade. Serves as connection point to four routes and Zones 1 and 2 Micro-Transit Service	Capital	Yes	\$4,500,000	1
2	Vehicle Purchases	New/replacement buses as specified in the Transit Asset Management Plan ⁴	Capital	Yes	\$650,000- \$1,500,000	2
3	Micro-Transit Zone 3	Expand the on-demand flex service to augment the fixed-route bus service with first and last mile connectivity to the Western Fort Pierce Area	Capital & Operating	No	\$325,000-\$450,000	NR ⁵
4	Transit Operations Center	Centralized operations and maintenance facility to serve the transit system fleet	Capital	Yes	\$25,000,000-\$28,000,000	9
5	Bus Route Infrastructure	Miscellaneous locations along the fixed routes with priority at transfer locations	Capital	Yes	\$500,000	7
6	Van Pool Service	Provide Van Pool Service for St. Lucie County residents to St. Lucie County employers	Operating	Yes	\$250,000	NR
7	Micro-Transit Zone 1	Sustain service levels in the Tradition/Gatlin Boulevard area beyond expiration of the previous FDOT Service Development Grant	Capital & Operating	Yes	\$325,000-\$450,000 ⁶	3
8	Micro-Transit Fort Pierce	Expand on Freebee services in City of Fort Pierce and continue to provide transportation in transit deserts throughout the County	Capital & Operating	No	\$535,000	4
9	Micro-Transit Zone 2	Expand the on-demand flex service to augment the fixed-route bus service with first and last mile connectivity to the Torino Boulevard area to sustain the existing service levels beyond the current FDOT Service Development Grant life of three years	Capital & Operating	Yes	\$325,000-\$450,000	5
10	Expand Local Services	Improve frequency to 30 minutes on high performing routes	Operating	Yes	\$800,000	8
11	Express Route Bus Service	Continue to link the Port St. Lucie and Fort Pierce Intermodal Hubs.	Capital & Operating	Yes	\$400,000	6
12	Jobs Express Terminal Regional Service	Regional bus service to West Palm Beach with express commuter services	Operating	Yes	\$460,500	10

¹LRTP: *SmartMoves 2045 Long Range Transportation Plan*, February 2021

²TDP: *Bus Plus, St. Lucie County FY 2020-FY 2029 Transit Development Plan Major Update*, June 2019

³Source of Estimated Cost: St. Lucie County Transit Staff, May 2024, unless otherwise noted

⁴*Transit Asset Management Plan*, November 2020

⁵NR: Not Ranked

Transportation Alternatives (TA) Projects

2024/25 Priority Ranking	Score ¹	Facility	Project Limits		Project Description	Project Source ²	Estimated Cost ²	2023/24 Priority Ranking
			From	To				
1	30.5	Sunrise Boulevard	Bell Avenue	NSLRWCD Canal 15	Sidewalk: 0.5 miles	2024 TA Grant Application ³	\$1,103,773 ⁴	20
2	25.5	Easy Street	US Highway 1	Silver Oak Drive	Sidewalk-1.0 miles		\$1,090,396 ⁶	2
3	50.0	Florida SUN Trail, Historic Fort Pierce Downtown Retrofit	Georgia Avenue	North State Route A1A	Bicycle Boulevard, Roadway Section Connections, and Railroad Crossing Improvements	TIP, Florida SUN Trail Grant, and St. Lucie WBN ⁵	TBD ⁷	3
4	42.5	Green River Parkway Trail	Martin County Line	Walton Road	Resurfacing of Shared-Use Path: 2.5 miles	City of Port St. Lucie, Florida SUN Trail, and St. Lucie WBN	\$350,000	Not Ranked
4	42.5	Oleander Avenue	Edwards Road	South Market Avenue	Sidewalk: 1.3 miles		\$1,500,000 ⁶	7
4	42.5	Oleander Avenue	Saeger Avenue	Beach Avenue	Sidewalk: 1.4 miles		\$1,650,000 ⁶	7
7	42.0	Lakehurst Drive	Bayshore Boulevard	Airoso Boulevard	Sidewalk: 1.3 miles	Under design by City of Port St. Lucie	\$825,000 ⁸	9
8	41.5	Indrio Road	U.S. Highway 1	Old Dixie Highway	Sidewalk: 0.2 miles		\$225,000 ⁶	12
9	40.5	Indrio Road	Kings Highway	U.S. Highway 1	Sidewalk: 2.6 miles		\$3,050,790 ⁶	17
10	40.0	Oleander Avenue	Midway Road	Saeger Avenue	Sidewalk: 1.5 miles		\$1,323,840	19
11	36.5	Angle Road	Kings Highway	North 53rd Street	Sidewalk: 1.3 miles		\$1,461,595 ⁶	12
12	36.0	17th Street	Georgia Avenue	Delaware Avenue	Sidewalk: 0.3 miles		\$74,268	13
12	36.0	Boston Avenue	25th Street	13th Street	Sidewalk: 0.8 miles		\$123,200	13
14	35.0	Abingdon Avenue	Import Drive	Savona Boulevard	Sidewalk: 0.9 miles	Under design by City of Port St. Lucie	\$575,000 ⁸	15
14	35.0	Brescia Street	Savage Boulevard	Gatlin Boulevard	Sidewalk: 1.3 miles		\$323,000 ⁸	15
16	33.5	Weatherbee Road	U.S. Highway 1	Oleander Avenue	Sidewalk: 0.5 miles		\$445,220	17
17	32.0	Range Line Road	Glades Cut Off Road	Martin County Line	Sidewalk: 6.1 miles		\$5,300,000 ⁶	18
17	32.0	West Midway Road	West of Glades Cut Off Road	Shinn Road Area	Sidewalk: 5.0 miles		\$5,753,580 ⁶	18
19	31.5	St. Lucie Boulevard	Kings Highway	North 25th Street	Sidewalk: 3.0 miles		\$2,600,000 ⁶	20
20	30.5	Sunrise Boulevard	Edwards Road	Midway Road	Sidewalk: 2.8 miles		\$2,250,000 ⁶	21
21	29.5	Bell Avenue	Oleander Avenue	Sunrise Boulevard	Sidewalk: 0.5 miles		\$411,836 ⁹	22

2024/25 Priority Ranking	Score ¹	Facility	Project Limits		Project Description	Project Source ²	Estimated Cost ²	2023/24 Priority Ranking
			From	To				
22	27.0	Old Dixie Highway	St. Lucie Boulevard	Turnpike Feeder Road	Sidewalk: 5.2 miles		\$6,066,780 ⁶	23
23	26.5	Glades Cut Off Road	Port St. Lucie City Boundary	Range Line Road	Sidewalk: 2.4 miles		\$2,830,390 ⁶	24
23	26.5	Keen Road	Angle Road	St. Lucie Boulevard	Sidewalk: 1.0 miles		\$1,160,000 ⁶	24
25	25.5	Selvitz Road	Edwards Road	South of Devine Road	Sidewalk: 1.8 miles		\$562,202	26
26	24.5	Juanita Avenue	North 53rd Street	North 41st Street	Sidewalk: 1.3 miles		\$393,004	27
27	15.5	Silver Oak Drive	Easy Street	East Midway Road	Sidewalk: 1.8 miles		\$2,076,392 ⁶	28
28	15.0	Taylor Dairy Road	Angle Road	St. Lucie Boulevard	Sidewalk: 1.0 miles		\$1,160,000 ⁶	29

¹Scores are based on the *St. Lucie TPO TA Project Prioritization Methodology*

²Project Source and Source of Estimated Cost: *SmartMoves 2045 Long Range Transportation Plan*, February 2021 (2045 LRTP), unless otherwise noted

³Project is anticipated to be programmed for construction in the FDOT FY 2024/25 - FY 2028/29 Work Program as a result of the 2023 TA Grant Cycle

⁴Source of Estimated Cost: 2024 TA Grant Application, March 2024

⁵WBN: Walk-Bike Network

⁶Source of Estimated Cost: St. Lucie County Engineering

⁷TBD: To be Determined

⁸Source of Estimated Cost: *City of Port St. Lucie Sidewalk Master Plan (Design and Construction), July 2017*

⁹Source of Estimated Cost: 2019 TA Grant Application



2023/24 List of Priority Projects (LOPP)

(Adopted June 7, 2023; Amended February 7, 2024)

Master List

2023/24 Priority Ranking	Major Gateway Corridor? ¹	Facility	Project Limits		Project Description	Project Status/Notes	In LRTP ² Cost Feasible Plan?	Estimated Cost	2022/23 Priority Ranking
			From	To					
1	N/A ³	St. Lucie TPO			Planning/administration as detailed in the Unified Planning Work Program		Yes	\$400,000	1
2	Yes	Midway Road	Glades Cut Off Road	Jenkins Road	Add 2 lanes, sidewalks, bicycle lanes	PE ⁴ underway, ROW ⁵ to start in FY 24/25	Yes	\$55,186,000 ⁶	2
3	Yes	Midway Road Turnpike Interchange Phase 2			New interchange with southbound off-ramp and northbound on-ramp		Yes	\$20,000,000 ⁷	4b
4	Yes	Kings Highway	Angle Road	Indrio Road	Add 2 lanes, sidewalks, bicycle lanes	PE underway, ROW to start in FY 23/24	Yes	\$142,162,000 ⁶	5
5	Yes	Northern/Airport Connector	Florida's Turnpike	Kings Highway	New multimodal corridor with interchanges at Florida's Turnpike and I-95		Yes	\$137,110,000 ⁸	6
6	Yes	Jenkins Road	Midway Road	Orange Avenue	Add 2 lanes to existing segments, construct 4 lanes for new segments, and add sidewalks and bicycle lanes	Initial PD&E ⁹ activities underway	Yes	\$51,890,000 ⁸	7
7	Yes	California Boulevard	Del Rio Boulevard	Crosstown Parkway	Add 2 lanes and shared-use paths		Yes	\$4,760,000 ⁸	NR ¹⁰
8 ¹¹	Yes	St. Lucie West Boulevard	Peacock Boulevard	Cashmere Boulevard	Add 2 lanes and multimodal paths	City to start design	Yes	\$22,000,000	NR

¹Landscape funding eligibility for capacity projects based on 2012 FDOT Landscape Policy

²LRTP: *SmartMoves 2045 Long Range Transportation Plan*, February 2021

³N/A: Not Applicable

⁴PE: Preliminary Engineering

⁵ROW: Right-of-Way Acquisition

⁶Source of Estimated Cost: Florida Department of Transportation District 4, June 2023

⁷Source of Estimated Cost: Strategic Intermodal System Cost Feasible Plan, May 2023

⁸Source of Estimated Cost: *SmartMoves 2045 Long Range Transportation Plan*, February 2021

⁹PD&E: Project Development and Environment Study

¹⁰NR: Not Ranked

¹¹For Transportation Regional Incentive Program (TRIP) Grant Funding Only

Local Projects for Carbon Reduction Program (CRP) Funding and Transportation Alternatives Additional (TAA) Funding

Funding Source	Facility/Segment or Intersection	Project Limits		Project Description	Estimated Cost	Project Source ¹	LAP-Certified Implementing Agency	Project Status/Notes
		From	To					
CRP	Midway Road	US-1	Selvitz Road	Install fiber optic cable along Midway Road and traffic cameras/video detectors and adaptive signal control at the signalized intersections	\$370,000	CMP ² LOPP ³	St. Lucie County	
CRP	Gatlin Boulevard at Savona Boulevard			Extend eastbound and westbound left-turn lanes on Gatlin Boulevard	\$750,000	CMP LOPP	City of Port St. Lucie	Right-of-way acquisition is not needed
TAA	Green River Parkway Trail	Martin County Line	Walton Road	Resurfacing of multi-use path: 2.5 miles	\$350,000	TA ⁴ LOPP	City of Port St. Lucie	
TAA	St. James Drive	NE Lazy River Parkway	NE Royce Avenue	Sidewalk, 6-8 feet in width, 0.25 mile in length	\$419,000	CSAP ⁵	St. Lucie County	
TAA	Nebraska Avenue	South Lawnwood Circle	South 13th Street	Sidewalks, 6 feet in width, 1 mile in length, on both sides of street	\$717,000	City of Fort Pierce	City of Fort Pierce	Project-specific LAP Certification is necessary

¹Source of Estimated Cost is from the Project Source unless otherwise noted

²CMP: Congestion Management Process

³LOPP: List of Priority Projects

⁴TA: Transportation Alternatives

⁵CSAP: Comprehensive Safety Action Plan

Congestion Management Process (CMP) Projects

(The St. Lucie TPO's allocation of Surface Transportation Block Grant funds to CMP projects is \$300,000 - \$400,000 annually)

2023/24 Priority Ranking	Facility/Segment or Intersection	Project Description	Project Status/Notes	Estimated Cost ¹	Project Source	2022/23 Priority Ranking
1	St. Lucie Transportation Management Center (TMC)	Design, construction, and installation of equipment including communication servers, video displays, and workstations that was originally included in Phase 1 of the ATMS Master Plan ²	Phase I of the ATMS Master Plan was completed without a TMC	\$400,000	ATMS Master Plan	1
2	Orange Avenue and South 7th Street (ATMS Master Plan Phase 2A)	Install fiber optic cable along Orange Avenue from US-1 to Kings Highway and along South 7th Street from Orange Avenue to Avenue A and traffic cameras/video detectors and adaptive signal control at the signalized intersections	PE ⁴ to start in FY 2026/27	\$700,000	ATMS Master Plan	3
3	Midway Road (ATMS Master Plan Phase 2B)	Install fiber optic cable along Midway Road from US-1 to Selvitz Road and traffic cameras/video detectors and adaptive signal control at the signalized intersections		\$370,000	ATMS Master Plan	4
4	Gatlin Boulevard at Savona Boulevard	Extend eastbound and westbound left turn lanes on Gatlin Boulevard and install dedicated northbound and southbound right turn lanes on Savona Boulevard	Right-of-way acquisition is not anticipated to be needed	\$750,000 ⁵	CMP	5

¹Source of Estimated Cost is from the Project Source unless otherwise noted

²ATMS Master Plan: *Advanced Transportation Management System (ATMS) Master Plan for St. Lucie County*, February 2013

³CMP: *St. Lucie Transportation Planning Organization Congestion Management Process Major Update*, June 2018

⁴PE: Preliminary Engineering

⁵Source of Estimated Cost: City of Port St. Lucie

Transit Projects

2023/24 Priority Ranking	Facility/Equipment/Service	Project Location/Description	Is Funding for Capital and/or Operating?	In LRTP ¹ or TDP ² ?	Estimated Cost ³	2022/23 Priority Ranking
1	Port St. Lucie Intermodal Hub	Phase 1 completed in 2013 - Location is in need of an upgrade. Serves as connection point to four routes and Zone 1 Micro-Transit Service	Capital	Yes	\$4,500,000	NR ⁴
2	Vehicle Purchases	New/replacement buses as specified in the Transit Asset Management Plan ⁵	Capital	Yes	\$100,000-\$650,000	3
3	Micro-Transit Zone 1	Sustain service levels in the Tradition/Gatlin Boulevard area beyond expiration of the previous FDOT Service Development Grant	Capital & Operating	Yes	\$325,000-\$450,000 ⁶	4
4	Micro-Transit Fort Pierce	Expand on Freebee services in City of Fort Pierce and continue to provide transportation in transit deserts throughout the County	Capital & Operating	No	\$800,000	NR
5	Micro-Transit Zone 2	Expand the on-demand flex service to augment the fixed-route bus service with first and last mile connectivity to the Torino Boulevard area to sustain the existing service levels beyond the current FDOT Service Development Grant life of three years	Capital & Operating	Yes	\$325,000-\$450,000 ⁶	NR
6	Express Route Bus Service	Continue to link the Port St. Lucie and Fort Pierce Intermodal Hubs with a zone through a potential Service Development Grant	Capital & Operating	Yes	\$800,000	2
7	Bus Route Infrastructure	Miscellaneous locations along the fixed routes with priority at transfer locations	Capital	Yes	\$200,000 (total for bus shelters)	7
8	Expand Local Services	Improve frequency to 30 minutes on high performing routes	Operating	Yes	\$800,000	6
9	Transit Operations Center	Centralized operations and maintenance facility to serve the transit system fleet	Capital	Yes	\$18,000,000-\$20,000,000	1
10	Jobs Express Terminal Regional Service	Regional bus service to West Palm Beach with express commuter services	Operating	Yes	\$460,500 ⁶	5

¹LRTP: *SmartMoves 2045 Long Range Transportation Plan*, February 2021

²TDP: *Bus Plus, St. Lucie County FY 2020-FY 2029 Transit Development Plan Major Update*, June 2019

³Source of Estimated Cost: St. Lucie County Transit Staff, May 2023, unless otherwise noted

⁴NR: Not Ranked

⁵*Transit Asset Management Plan*, November 2020

⁶*Jobs Express Terminal Connectivity Study*, June 2020

Transportation Alternatives (TA) Projects

2023/24 Priority Ranking	Score ¹	Facility	Project Limits		Project Description	Project Source ²	Estimated Cost ²	2022/23 Priority Ranking
			From	To				
1	38.0	Peacock Trail	Gatlin Boulevard	Dreyfuss Boulevard	Shared-Use Path: 1.0 mile	2023 TA Grant Application ³	\$1,674,174 ⁴	11
2	25.5	Easy Street	US Highway 1	Silver Oak Drive	Sidewalk-1.0 miles		\$1,090,396 ⁶	2
3	50.0	Florida SUN Trail, Historic Fort Pierce Downtown Retrofit	Georgia Avenue	North State Route A1A	Bicycle Boulevard, Roadway Section Connections, and Railroad Crossing Improvements	TIP, Florida SUN Trail Grant, and St. Lucie WBN ⁵	TBD ⁷	3
4	42.5	Green River Parkway Trail	Martin County Line	Walton Road	Resurfacing of Shared-Use Path: 2.5 miles	City of Port St. Lucie, Florida SUN Trail, and St. Lucie WBN	\$350,000	Not Ranked
4	42.5	Oleander Avenue	Edwards Road	South Market Avenue	Sidewalk: 1.3 miles		\$1,500,000 ⁶	7
4	42.5	Oleander Avenue	Saeger Avenue	Beach Avenue	Sidewalk: 1.4 miles		\$1,650,000 ⁶	7
7	42.0	Lakehurst Drive	Bayshore Boulevard	Airoso Boulevard	Sidewalk: 1.3 miles	Under design by City of Port St. Lucie	\$825,000 ⁸	9
8	41.5	Indrio Road	U.S. Highway 1	Old Dixie Highway	Sidewalk: 0.2 miles		\$225,000 ⁶	12
9	40.5	Indrio Road	Kings Highway	U.S. Highway 1	Sidewalk: 2.6 miles		\$3,050,790 ⁶	17
10	40.0	Oleander Avenue	Midway Road	Saeger Avenue	Sidewalk: 1.5 miles		\$1,323,840	19
11	36.5	Angle Road	Kings Highway	North 53rd Street	Sidewalk: 1.3 miles		\$1,461,595 ⁶	12
12	36.0	17th Street	Georgia Avenue	Delaware Avenue	Sidewalk: 0.3 miles		\$74,268	13
12	36.0	Boston Avenue	25th Street	13th Street	Sidewalk: 0.8 miles		\$123,200	13
14	35.0	Abingdon Avenue	Import Drive	Savona Boulevard	Sidewalk: 0.9 miles	Under design by City of Port St. Lucie	\$575,000 ⁸	15
14	35.0	Brescia Street	Savage Boulevard	Gatlin Boulevard	Sidewalk: 1.3 miles		\$323,000 ⁸	15
16	33.5	Weatherbee Road	U.S. Highway 1	Oleander Avenue	Sidewalk: 0.5 miles		\$445,220	17
17	32.0	Range Line Road	Glades Cut Off Road	Martin County Line	Sidewalk: 6.1 miles		\$5,300,000 ⁶	18
17	32.0	West Midway Road	West of Glades Cut Off Road	Shinn Road Area	Sidewalk: 5.0 miles		\$5,753,580 ⁶	18
19	31.5	St. Lucie Boulevard	Kings Highway	North 25th Street	Sidewalk: 3.0 miles		\$2,600,000 ⁶	20
20	30.5	Sunrise Boulevard	Edwards Road	Midway Road	Sidewalk: 2.8 miles		\$2,250,000 ⁶	21
21	29.5	Bell Avenue	Oleander Avenue	Sunrise Boulevard	Sidewalk: 0.5 miles		\$411,836 ⁹	22

2023/24 Priority Ranking	Score ¹	Facility	Project Limits		Project Description	Project Source ²	Estimated Cost ²	2022/23 Priority Ranking
			From	To				
22	27.0	Old Dixie Highway	St. Lucie Boulevard	Turnpike Feeder Road	Sidewalk: 5.2 miles		\$6,066,780 ⁶	23
23	26.5	Glades Cut Off Road	Port St. Lucie City Boundary	Range Line Road	Sidewalk: 2.4 miles		\$2,830,390 ⁶	24
23	26.5	Keen Road	Angle Road	St. Lucie Boulevard	Sidewalk: 1.0 miles		\$1,160,000 ⁶	24
25	25.5	Selvitz Road	Edwards Road	South of Devine Road	Sidewalk: 1.8 miles		\$562,202	26
26	24.5	Juanita Avenue	North 53rd Street	North 41st Street	Sidewalk: 1.3 miles		\$393,004	27
27	15.5	Silver Oak Drive	Easy Street	East Midway Road	Sidewalk: 1.8 miles		\$2,076,392 ⁶	28
28	15.0	Taylor Dairy Road	Angle Road	St. Lucie Boulevard	Sidewalk: 1.0 miles		\$1,160,000 ⁶	29

¹Scores are based on the *St. Lucie TPO TA Project Prioritization Methodology*

²Project Source and Source of Estimated Cost: *SmartMoves 2045 Long Range Transportation Plan*, February 2021 (2045 LRTP), unless otherwise noted

³Project is anticipated to be programmed for construction in the FDOT FY 2024/25 - FY 2028/29 Work Program as a result of the 2023 TA Grant Cycle

⁴Source of Estimated Cost: 2023 TA Grant Application, March 2023

⁵WBN: Walk-Bike Network

⁶Source of Estimated Cost: St. Lucie County Engineering

⁷TBD: To be Determined

⁸Source of Estimated Cost: *City of Port St. Lucie Sidewalk Master Plan (Design and Construction)*, July 2017

⁹Source of Estimated Cost: 2019 TA Grant Application



AGENDA ITEM SUMMARY

Board/Committee:	Technical Advisory Committee (TAC)
Meeting Date:	May 21, 2024
Item Number:	6c
Item Title:	City of Fort Pierce Passenger Rail Station/Mobility Hub Concepts Plan
Item Origination:	Unified Planning Work Program (UPWP)
UPWP Reference:	Task 3.2 – Transit Planning
Requested Action:	Recommend acceptance of the Concepts Plan, recommend acceptance with conditions, or do not recommend acceptance.
Staff Recommendation:	Because the identification and analysis of potential sites for a passenger rail station in downtown Fort Pierce would position the City of Fort Pierce to take advantage of future funding opportunities, it is recommended that the City of Fort Pierce Passenger Rail Station/Mobility Hub Concepts Plan be recommended for acceptance by the TPO Board.

Attachments

- Staff Report
- Fort Pierce Passenger Rail Station/Mobility Hub & Station Concept Plan



Coco Vista Centre
 466 SW Port St. Lucie Blvd, Suite 111
 Port St. Lucie, Florida 34953
 772-462-1593 www.stlucietpo.org

MEMORANDUM

TO: Technical Advisory Committee (TAC)

THROUGH: Peter Buchwald
 Executive Director

FROM: Marceia Lathou
 Transit/ACES Program Manager

DATE: May 14, 2024

SUBJECT: City of Fort Pierce Passenger Rail Station/Mobility
 Hub Concepts Plan

BACKGROUND

Downtown Fort Pierce is strategically located to support passenger rail service. The downtown offers history, art, vibrant retail, and scenic views, all within walking distance of the Florida East Coast (FEC) railroad system. Adjacent to the FEC tracks are vacant, undeveloped properties suitable for the development of a passenger rail station.

Passenger rail service could be provided by several sources. Tri-Rail, South **Florida's commuter rail** service, could extend to the Treasure Coast. Amtrak, **the nation's** intercity rail service, could re-establish a route **along Florida's east** coast. The explosive population and employment growth being experienced by St. Lucie County underscores the need for regional connectivity supported by passenger rail.

The City of Fort Pierce has garnered substantial support for a passenger rail station in downtown Fort Pierce. The support comes from the public and from municipal and private organizations throughout St. Lucie, Indian River, and Okeechobee counties. These stakeholders recognize the potential of a downtown Fort Pierce station as an economic, tourism, and cultural asset for the entire region.

At its April 12, 2023 meeting, the TPO Board amended Task 3.2 Transit Planning of the FY 2022/23 – FY 2023/24 Unified Planning Work Program

(UPWP) to add Fort Pierce Passenger Rail Station Planning as a project to develop initial site plans and conceptual designs for a passenger rail station in downtown Fort Pierce. The scope of this project also incorporated the concept of mobility hubs -- seamless integration with all modes of ground transportation -- **as outlined in the TPO's Sustainable Transportation Plan**. A mobility hub could be implemented in advance of a rail station to continue building synergy for passenger rail service by being designed with an envelope for station operations and a passenger platform.

ANALYSIS

MARLIN Engineering Inc., with subconsultants Zyscovich Architects, developed the attached Concepts Plan entitled "Fort Pierce Passenger Rail Station/ Mobility Hub & Station Concept Plan". The plan includes conceptual station area planning, traffic engineering, architectural design, and roadway design evaluations for three alternative sites for a rail station/mobility hub in downtown Fort Pierce. A summary of each proposed site is provided below:

Audubon Development/H.D. King's Landing Site

- The 7.2-acre parcel is part of the H.D. King Plant Site, a Mixed-Use Development by Audubon Development
- Waterfront property across from Fort Pierce City Marina in Downtown Fort Pierce
- Located adjacent to the FEC railroad
- Zoning - former Light Industrial, now Approved Planned Development

Boston Avenue Site

- 7.02-acre parcel
- Situated on the western side of the FEC rail right of way, just south of Orange Avenue
- Owned by FEC and adjacent to the FEC railroad
- Parcel is currently zoned C-4 - General Commercial Zoning and PD - Planned Development

Depot Drive Site

- 0.90-acre- parcel fronting FEC, expanded to 2.47 acres with County and private property
- Situated on the eastern side of the FEC rail right of way, directly behind the Sunrise Theatre
- Owned by the City of Fort Pierce, St. Lucie County, and private property owner
- It is currently utilized for surface parking, however, a large portion of it is undeveloped
- Parcel is currently zoned C-4, Central Commercial Zoning

The plan includes concepts of what the stations would look like, how they would connect to the rest of Fort Pierce, and the benefits of each location. The plan was coordinated with the City of Fort Pierce and related municipal departments and agencies during the planning process. A representative from MARLIN Engineering will present highlights of the plan.

RECOMMENDATION

Because the identification and analysis of potential sites for a passenger rail station in downtown Fort Pierce would position the City of Fort Pierce to take advantage of future funding opportunities, it is recommended that the City of Fort Pierce Passenger Rail Station/Mobility Hub Concepts Plan be recommended for acceptance by the TPO Board.



ST. LUCIE TPO

Fort Pierce Passenger Rail Station/ Mobility Hub & Station Concept Plan



St. Lucie Transportation
Planning
Organization

APRIL 2024 | Draft Final



PREPARED BY

MARLIN



ST. LUCIE TPO

Fort Pierce Passenger Rail Station/ Mobility Hub & Station Concept Plan

PREPARED FOR:



PREPARED BY:

MARLIN

MARLIN Engineering, Inc.
3363 W Commercial Blvd, Suite 115
Fort Lauderdale, FL 33309





Table of Contents

- Executive Summary..... E-1**
 - Background..... E-1
 - Opportunity E-1
 - Station Area and Layout and ACES Mobility Hub Design E-2
- Chapter 1. Introduction..... 1**
 - Background..... 1
 - Candidate Sites 3
 - Guiding Documents 4
 - Treasure Coast Regional Transportation Plan 4
 - St Lucie TPO Smart Moves 2045 LRTP 6
 - Automated Connected Electric and Shared-Use (ACES) Sustainable Transportation Plan 6
 - St Lucie County Transit Development Plan..... 8
 - Downtown Fort Pierce Master Plan..... 8
 - 2023 Fort Pierce Strategic Plan 9
 - St. Lucie TPO Micro-Mobility Study 11
- Chapter 2. Access and Connectivity 12**
 - Downtown Fort Pierce..... 12
 - Fort Pierce Multimodal Connectivity 12
 - Train Station Trip Generation and Roadway Connectivity 13
 - Crash History 15
 - St. Lucie ART Connections 15
 - MicroTransit Connectivity 17
 - PedestrianBicycle/Micromobility Connectivity 18
 - Florida East Coast Greenway and SUNTrail..... 20
- Chapter 3. Station Area Planning 22**
 - Audubon Development/H.D. King’s Landing Site..... 22
 - Boston Avenue Site 22
 - Depot Drive Site..... 22
 - Audubon Development/King’s Landing Site..... 24
 - Boston Avenue Site 27
 - Depot Drive Site..... 29
 - Downtown Fort Pierce Development Potential 30
- Chapter 4. Station Area Concept..... 34**





Brightline RFP 34

Zoning 36

Station Layout..... 36

Site Access 38

Parking..... 39

Chapter 5. Partners 42

Appendices 45

Appendix A - Parking, Traffic and Crash Reports..... 45

Appendix B - Support Letters 45

Appendix C - City of Fort Pierce Brightline Proposal 45

Appendix D - Station Floor Plan..... 45

List of Figures

Figure 1: Fort Pierce Regional Location 1

Figure 2: 2045 Treasure Coast RL RTP Regional Transit Needs 5

Figure 3: 2045 Smart Moves LRTP Transit Needs Plan 7

Figure 4: Downtown Master Plan Existing and Recommended CBD Land Use and Density 10

Figure 5: Three Selected Sites and Proximity to Key Employment Centers 13

Figure 6: AADT and Level of Service (LOS) Map 14

Figure 7: Regional Access AADT and Level of Service (LOS) Map 15

Figure 8: St. Lucie Area Regional Transit (ART) Routes 1, 2, 3, 7, and 8 16

Figure 9: Fort Pierce Tram Stops 18

Figure 10: Downtown Fort Pierce Micromobility Recommendations 19

Figure 11: 2024 Non-Motorized/Micromobility Monthly Traffic Totals, per mode 20

Figure 12: St. Lucie County East Coast Greenway 21

Figure 13: Audubon Development Site 23

Figure 14: Boston Avenue and Depot Drive Sites 24

Figure 15: IRSC Rendering of Passenger Rail Station and Culinary School 26

Figure 16: Potential Audubon Development/King’s Landing Development Concept 27

Figure 17: Downtown Master Plan 10+ Years Development - Brightline Station (2) at Boston Ave Site 28

Figure 18: Downtown Fort Pierce Green Promenade 30

Figure 19: Three Sites & Existing Development Scenario 31

Figure 20: Three Sites & Mid-Range (Present to 10 Years) Development Scenario 32

Figure 21: Three Sites & Long-Range (10 Plus Years) Development Scenario 33

Figure 22: Depot Drive Existing Conditions Photos 34

Figure 23: Parcel Layout and Ownership 35

Figure 24: Site Location and Zoning 36



Figure 25: Station, Platform and Rail layout	37
Figure 26: Station Floor Plan	38
Figure 27: Pedestrian Friendly Station Main Access with Transit and Bike Share	38
Figure 28: EV Parking Spaces in Close Proximity to Station Main Entrance	39
Figure 29: North End of Station Paseo Connection to Orange Avenue	40
Figure 30: Proposed Parking	40
Figure 31: Downtown Parking Inventory	41

Appendices

- [Appendix A](#) - Parking, Traffic and Crash Reports
- [Appendix B](#) - Support Letters
- [Appendix C](#) - City of Fort Pierce Brightline Proposal
- [Appendix D](#) - Station Floor Plan



Executive Summary

Background

The St. Lucie Transportation Planning Organization (TPO) has initiated this study as a next step in its goal to bring intercity and regional passenger rail service to St. Lucie County. The study addresses well documented opportunities such as regional connectivity, development, and population and employment growth that support a plan for a passenger rail station in Downtown Fort Pierce. Potential station locations in Downtown have been identified and architectural renderings of a candidate location are also provided. Downtown Fort Pierce is the focus of this effort as it has been consistently documented in TPO Planning documents as the preferred location for a regional passenger rail station in St. Lucie County and the study was performed in close coordination with the City.

The St. Lucie TPO also recently prepared the Autonomous, Connected, Electric and Shared Use (ACES) Sustainable Transportation Plan to facilitate a countywide energy-efficient transportation network. The plan involves developing strategically placed Mobility Hubs to provide the county, including Downtown Fort Pierce, with transportation infrastructure facilitating public/private sustainable transport modes such as electric bus, electric, autonomous vehicles, ride-sharing, micromobility, and pedestrian/bicycle connectivity. This study approached the development of the passenger rail station as an ACES mobility hub. The mobility hub element is critically important as it will create a centralized node for pedestrian, bicycle and trails; transit; parking; microtransit and micromobility at a high-profile location. The downtown hub is ranked as Priority #1 in the ACES plan and the mobility hub could be implemented in advance of a rail station to continue building synergy for passenger rail by being designed with an envelope for station operations and a passenger platform.

Fort Pierce is a city primed for growth, holding massive economic potential with a new Downtown Master Plan that is inspiring, creative and open to welcoming new businesses. The TPO and City leaders have proactively pursued the prospect of establishing a train station within the Downtown, exploring partnerships with Amtrak, Tri-Rail, and Brightline. The city has garnered substantial support and commitment from St. Lucie County, various municipal and private organizations, as well as regional partners in Okeechobee and Indian River County. These stakeholders recognize the potential of the station as an economic, tourist, and cultural asset for the entire region.

Opportunity

On October 26, 2023 Brightline announced that it is seeking proposals from public and private entities to identify a station location for their Treasure Coast station. The RFP identified specific criteria that must be met for an application to be competitive including a requirement that only proposals from current property owners and those that have property under contract will be considered. Brightline was not interested in receiving proposals from persons, firms, entities, or organizations that do not control the property as defined in the RFP. The RFP also had a short timeline, due by December 22, 2023.



At this point, the Project Team pivoted to take advantage of an immediate opportunity to land a passenger rail station with intercity service in Fort Pierce. As a result, the Depot Drive Site was selected as the best opportunity because the City and the County owned a majority of the land for the station area.

Depot Drive Site is located on the Eastern side of the FEC rail right-of-way south of Orange Avenue. Two (2) City of Fort Pierce parcels total 1.23 acres and are dedicated to the development of the station, platforms, circulation, and station access. A private partner owns the third parcel and has provided a willing seller letter to the City. Should a rail operator select the City’s proposed site for the Station, the City of Fort Pierce will acquire the privately owned 0.32 acre parcel and seamlessly integrate it into the station plan.

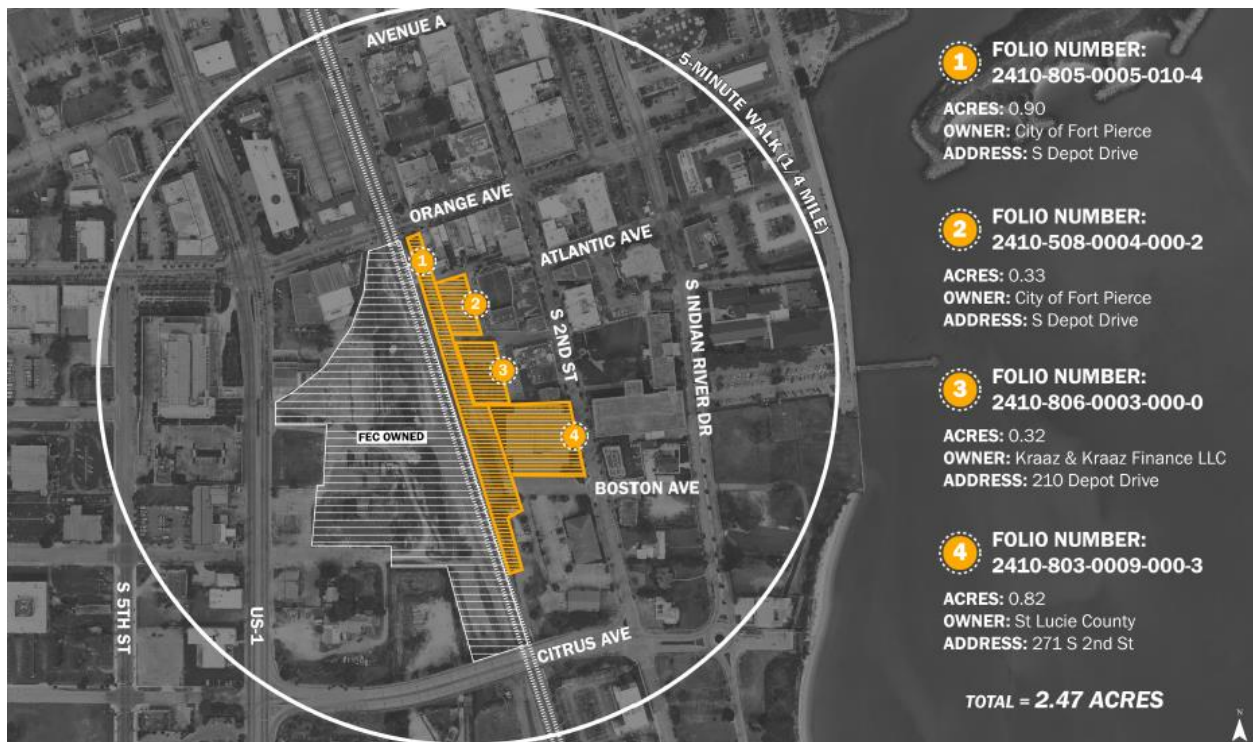

Parcel Layout and Ownership

St. Lucie County owns the 4th parcel at .82 acres which includes a public parking garage that is proposed to be expanded and made available to passenger rail patrons.

Station Area and Layout and ACES Mobility Hub Design

A station layout was prepared for the Depot Drive Site, but it must be noted that the site design and architectural renderings for a train station are very similar no matter where they are located. The renderings and concepts developed for the station are, for the most part, transferable to any site selected for the Fort Pierce Passenger Rail Station Mobility Hub. The station layout is designed in a linear fashion



along the east side of FEC Right-of-Way to accommodate a passenger platform and station. Note that a new rail side track is necessary to serve the station and not obstruct mainline rail activity. The layout is provided in the graphic below.



Station, Platform and Rail layout

The site circulation has been designed as a mobility hub facilitating seamless integration with all modes of ground transportation. The main station entrance is designed in a pedestrian-friendly environment designed for very slow traffic, a pick-up and drop-off traffic circle for rideshare and ART bus, Fort Pierce Tram shelter and a bike share rack located directly at the main entrance to the station. The site design also includes electric vehicle charging stations at parking stalls, Electric Vehicle (EV) bike-share racks, and EV scooter stations near the main entrance of the station. Various renderings depicting a potential station and ACES are provided below.



North Station Paseo Entrance, Platform and Rail layout



Station Area View from the South



Pedestrian Friendly Station Main Entrance with Transit and Bike Share



EV Parking Spaces in Close Proximity to Station Main Entrance



North End of Station Paseo Connection to Orange Avenue



Chapter 1. Introduction

Background

The St. Lucie Transportation Planning Organization (TPO) has initiated this study as a next step in its goal to bring intercity and regional passenger rail service to St. Lucie County that will complement the transportation network and provide a more efficient and sustainable mode of travel for residents, businesses and visitors. This study identifies the regional need for passenger rail and the opportunities that the City of Fort Pierce provides as the station location. Potential station locations in Downtown Fort Pierce have been identified and architectural renderings of a candidate location are also provided. Downtown Fort Pierce is the focus of this effort as it has been consistently documented in TPO Planning documents as the preferred location for a regional passenger rail station in St. Lucie County and the study was performed in close coordination with the City of Fort Pierce.

Downtown Fort Pierce is strategically located to support regional passenger rail as it lies in the center of the Treasure Coast region and is proximate to major markets to the north and to the south. Distances to major business districts and tourism hot spots include - Orlando Central Business (CBD) – 120 miles; West Palm Beach CBD – 63 miles; Fort Lauderdale CBD – 100 miles and Miami CBD – 125 miles.

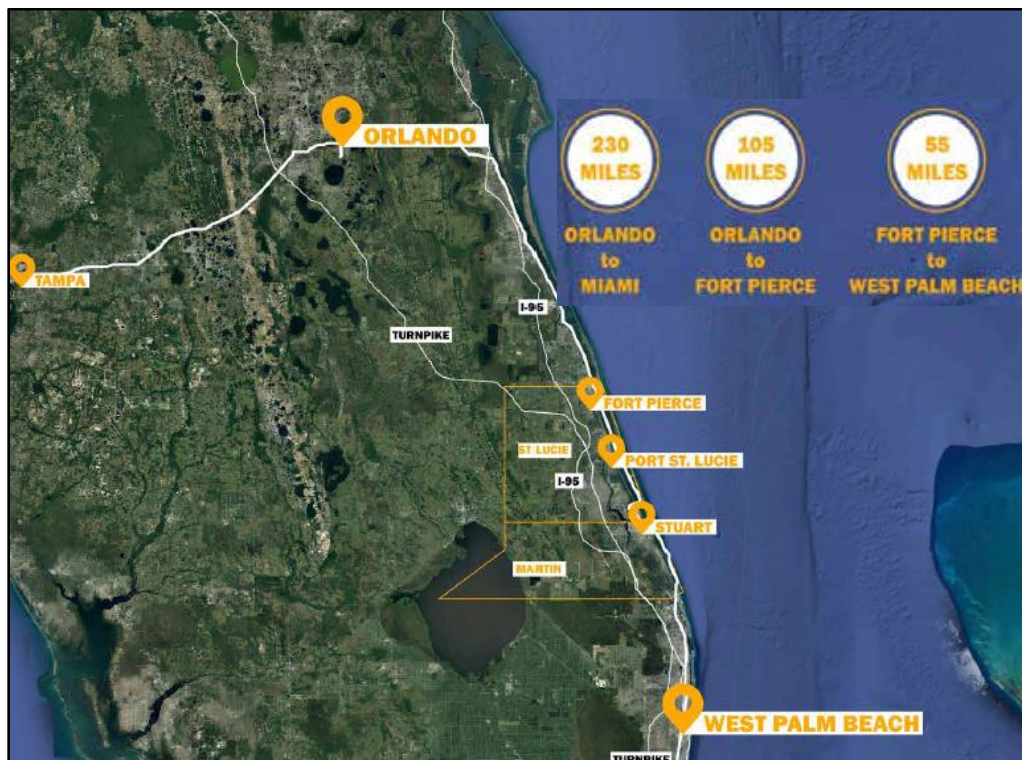

Figure 1: Fort Pierce Regional Location



Fort Pierce boasts a unique blend of natural beauty, rich cultural heritage, immense economic potential and a robust history tied to railroad, seaport and airport trade and transportation. The City was populated in the latter part of the 19th Century as a direct result of Henry Flagler’s Florida East Coast Railroad (FEC) arrival in Fort Pierce in 1894. Many of the citizens descend from railroad workers and travelers. FEC made Fort Pierce a major stop precisely because it was approximately halfway between Jacksonville and St. Augustine to the North, and Miami to the South. Fort Pierce’s geographic location is also ideal for intercity passenger rail service as the proposed station is equidistant between Orlando and Miami.

For many years, the TPO, County Stakeholders and City Leaders have actively advocated for a railroad station in Fort Pierce, including AMTRAK, South Florida Regional Transit Authority Tri-Rail (TriRail) and, most recently, Brightline. The City also supports railroad industry development including a concrete railroad tie plant and other industrial projects that contribute to, and benefit from, railroad commerce.

Downtown Fort Pierce is ideal for a regional rail station for many reasons including:

- **Business-Friendly:** Fort Pierce is a progressive and supportive local government that is business-friendly and working to ensure it remains relevant and attractive. The City is committed to accommodating interested businesses and developers throughout the application and permitting process to ensure appropriate projects can proceed efficiently.
- **Financial Stability:** In times of economic volatility, the City of Fort Pierce increased its general fund budget year-over-year with a 6.1 percent increase in the taxable value of properties in the city bringing in approximately \$2.7 million in additional revenues.
- **Undeveloped Land:** Unlike metro areas to the south, Fort Pierce has large parcels of vacant and undeveloped land available for development.
- The recently completed **Fort Pierce Downtown Master Plan** promotes mixed-use opportunities for a large section of the downtown business area. In addition, it identifies a potential location for a passenger rail station as a Transit Oriented Development (TOD). The improvement of the central business district offers a massive opportunity for the City of Fort Pierce to complete the vision to develop it as a transit-oriented, mixed-use thriving core and to generate substantial property tax returns, as well as indirect economic benefits.
- The City of Fort Pierce has been proactive in supporting retail activity through a **Comprehensive Market and Retail Feasibility Study (Phase I)** and a **Retail Strategy Plan (Phase II)**. City leadership recognized the need to work strategically to evaluate its retail profile and evolve the shopping and dining offerings through a comprehensive market and retail feasibility analysis, and the development of a retail strategic plan for the Community Redevelopment Area and other commercial districts.
- **Accessibility:** Fort Pierce is located near the junction of I-95 and Florida's Turnpike (Turnpike) on the west side of the City making it an ideal “milepost” for tourists or commuters. It is also served



by the Treasure Coast International Airport which is just 3.5 miles north of the Fort Pierce Redevelopment Area (FPRA), and the Port of Fort Pierce is located within the FPRA. Passengers stepping off the train would be within walking distance of transportation options, employment centers, recreation, and the waterfront.

- **Entertainment:** Fort Pierce features contemporary shopping, dining, great fishing, and a range of entertainment and activities from the Farmers Market, Bike Night, Friday Fest, and Jazz Market to the city-owned and operated historic, 1,200-seat Sunrise Theatre for the Performing Arts.
- **Education:** Fort Pierce is home to several educational and research facilities, like the top-ranked Indian River State College (IRSC), Smithsonian Marine Station, Manatee Observation and Education Center and Harbor Branch Oceanographic Institution at Florida Atlantic University.
- **Amenities:** With the close proximity to the Atlantic Ocean via the Fort Pierce inlet, it affords numerous fishing opportunities for both recreational and commercial fishermen and is a short distance to the Bahamas. Fishing and boating are a major part of the local economy with several boat companies and marinas located in the area.
- **Low Cost of Living:** Housing is affordable for Fort Pierce residents. The median household income in Fort Pierce is \$35,572 and the median home value is approximately \$172,000 according to Zillow. However, home values are steadily increasing at 6.1 percent year-over-year as of October 2020
- **Diversity:** Fort Pierce is a diverse and neighborly community. According to Niche, Fort Pierce ranks as the most diverse place to live in St. Lucie County.

Candidate Sites

The study is phased to first present the potential of the Downtown Fort Pierce area to support a passenger rail station and then to evaluate three (3) alternative sites located along the FEC corridor. One (1) site will then be selected for the development of a station area plan that includes mobility hub options that connect the station to the greater area. The alternative sites were identified by the TPO and City Staff (Project Team) as part of scoping this effort. The sites will be evaluated for a regional passenger rail station/mobility hub based on multiple factors including parcel size and redevelopment potential. The mobility hub aspect holds significant importance as it will establish a centralized node for pedestrian, bicycle, and trail access, as well as for motorized, Autonomous, Connected, Electric, and Shared (ACES) technologies, and micro-transit, all situated at a prominent location. In fact, the mobility hub could be implemented in advance of a rail station to continue building synergy for passenger rail by being designed with an envelope for station operations and a passenger platform. The proposed three (3) locations, identified by the City of Fort Pierce and the TPO, for evaluation include:

- **Audubon Development Inc./H.D. Kings Landing:** Parcel #2410-503-0034-000-6 plus the adjoining parcels also owned by Audubon Development Inc.



- **Boston Avenue:** Parcel #2410-701-0002-000-1 plus the adjoining parcels also owned by FEC. These are south of Orange Avenue between the tracks and US 1.
- **Depot Drive:** Parcel #2410-805-0005-010-4 which is south of Orange Avenue, on the east side of the tracks, and is owned by the City of Fort Pierce.

Guiding Documents

Treasure Coast Regional Transportation Plan

The 2045 Treasure Coast Regional Long Range Transportation Plan (2045 RL RTP) establishes a regional transportation network and combines the regional projects from the local transportation plans for Martin, St. Lucie and Indian River Counties to create a long term transportation plan for the regional transportation network. The Treasure Coast has experienced a large influx of people over the past 30 years. From 1985 to 2015, the Treasure Coast more than doubled in population growing from 273,663 people to a population of 587,284, according to data from the U.S. Census Bureau. The Treasure Coast is expected to grow by an additional 377,575 people for a total population of 964,859 residents and a percent growth of 64.29% between 2015 to 2045. This growth will increase demand for a comprehensive and efficient multimodal transportation network including regional and intercity passenger rail.

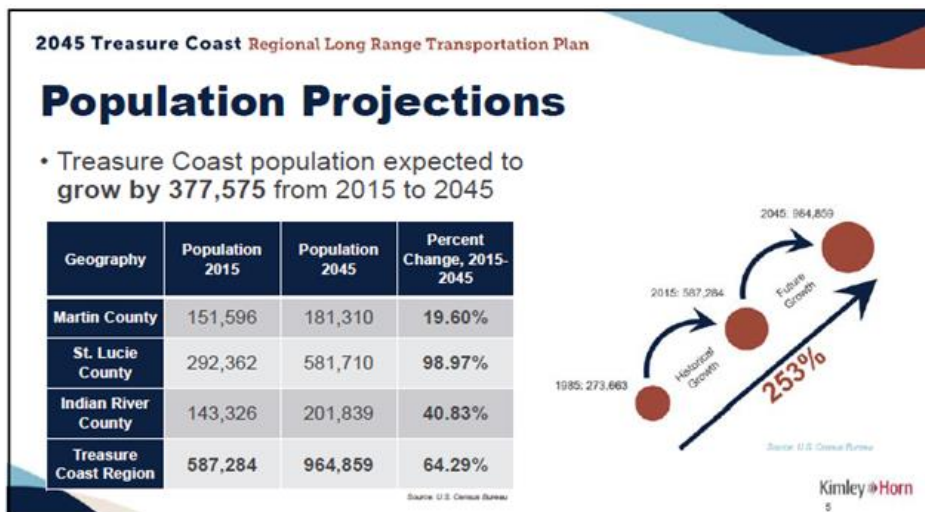

Further, population growth is not uniform throughout the region as St. Lucie County houses approximately one-half of the population of the region, while Martin County and Indian River County each contain about one-quarter of the population. This is primarily the result of a higher percentage of population growth in St. Lucie County since 1985 (152%) than in Indian River County (89%) or Martin County (85%). The trend



of a higher population growth percentage in St. Lucie County is anticipated to continue in the foreseeable future.

There are five (5) existing transit routes that cross County lines in the Treasure Coast and the 2045 RL RTP shows the need for five (5) additional regional transit needs including the extension of the TriRail commuter rail service from the Mangonia Park station in Palm Beach County to Fort Pierce. **Figure 2** shows the existing regional routes and the five (5) new regional projects including the TriRail Extension.

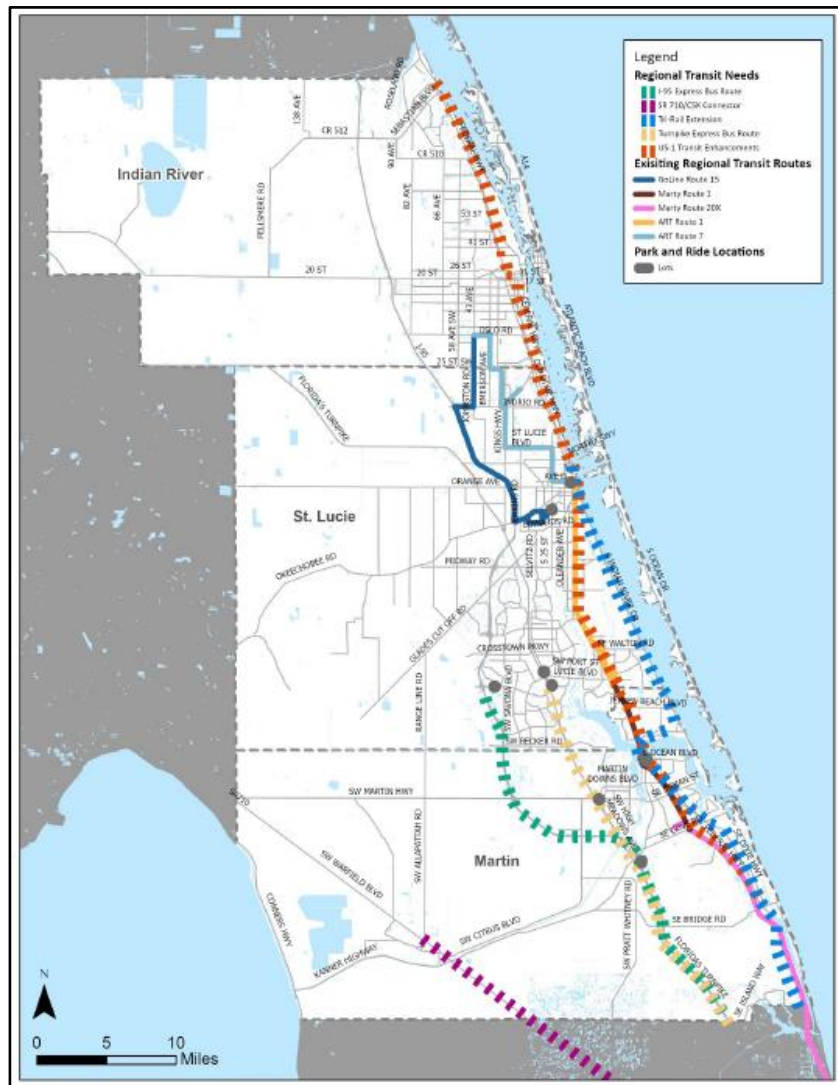

Figure 2: 2045 Treasure Coast RL RTP Regional Transit Needs



St Lucie TPO Smart Moves 2045 L RTP

St. Lucie TPO Smart Moves 2045 Long Range Transportation Plan (2045 L RTP) sets the overall trajectory of the county’s investments in transportation. The 2045 L RTP supports the overarching themes of: ACES options, a Congestion Management Process, Transportation Systems Management and Operations, and an Advanced Transportation Management System. The top goals of the 2045 L RTP plan are:

- Support Economic Activities
- Provide Travel Choices
- Maintain Transportation System
- Provide Equitable, Affordable, Sustainable Urban Mobility
- Improve Safety and Security



The population and employment growth forecast for the TPO plan is similar to the Regional Plan. The 2045 L RTP shows the population and employment growth forecast expected to occur over the next 25 years projecting an 80 percent (80%) increase in population and a 76% increase in employment by 2045. The plan also includes a Transit Needs Analysis that recommends a Passenger Rail Service Miami to Orlando. **Figure 3** on the following page displays the 2045 Transit Needs Plan.

Automated Connected Electric and Shared-Use (ACES) Sustainable Transportation Plan

The St. Lucie TPO also recently prepared the ACES Sustainable Transportation Plan to facilitate an energy-efficient transportation network. The plan involves developing strategically placed Mobility Hubs to provide the St. Lucie TPO area, including Downtown Fort Pierce, with transportation infrastructure facilitating public/private sustainable transport modes such as passenger rail, electric bus, electric, autonomous vehicles, ride-sharing, micro-mobility, and pedestrian/bicycle connectivity. Mobility Hubs are a growing urban typology facilitating multi-modal transport through improved bicycle, pedestrian, micro-mobility, and transit infrastructure connecting at strategically located hubs. Mobility Hub infrastructure examples include: enhanced crosswalks, improved sidewalks, bike lanes, separated bike lanes, shared paths/trails, way-finding signage, bicycle/scooter racks, sheltered seating, public information,

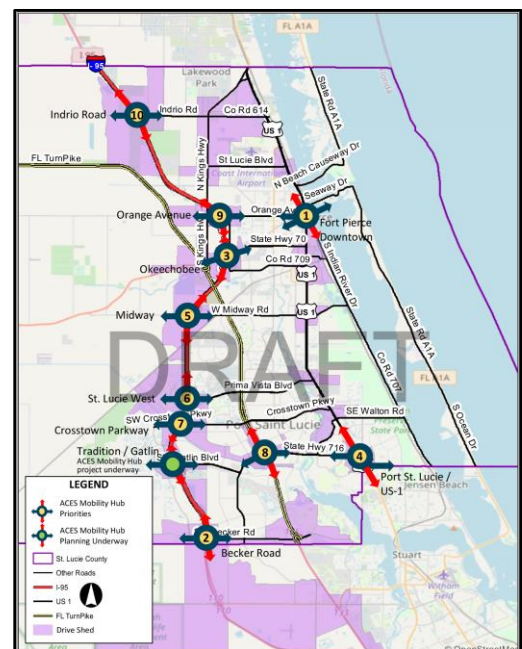



mobile ticketing booths, and other potential amenities such as public art, retail, food vendors, additional government services, and more.

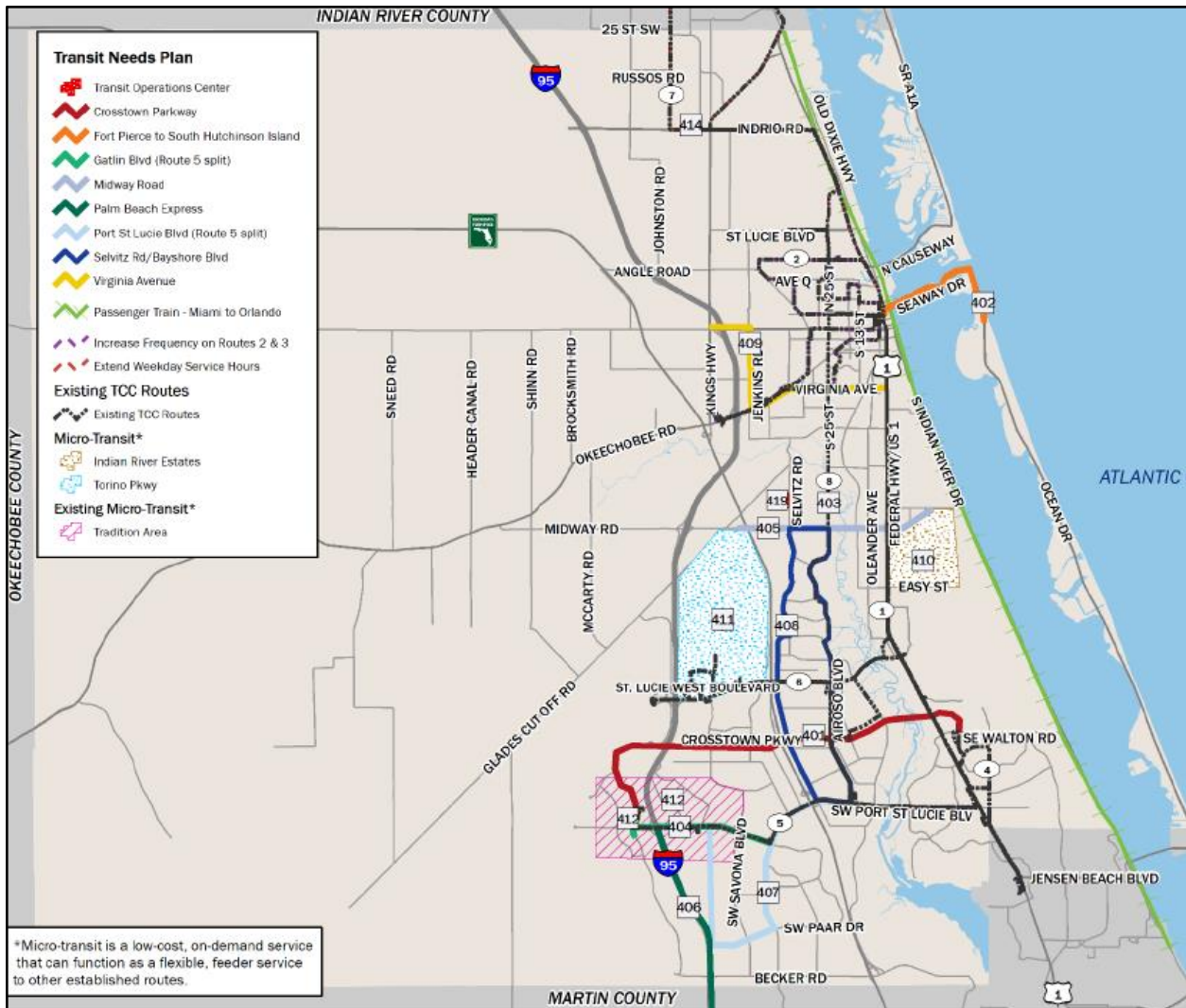

Figure 3: 2045 Smart Moves LRTP Transit Needs Plan

Developing a passenger rail station in downtown Fort Pierce aligns with the direction local agencies and the public are supporting for sustainable growth in Fort Pierce and St. Lucie County. According to the St. Lucie TPO ACES Sustainable Transportation Plan, the Downtown Fort Pierce Mobility Hub is listed as Priority #1 among the ten recommended locations for future hubs around the county. The downtown location scored highest due to numerous factors, including existing transit connectivity, evacuation routes, current and future population density, current and future employment density, mixed-use



development, available publicly owned land, hospital proximity, and economic opportunity, among other criteria.

St Lucie County Transit Development Plan

The St. Lucie County 10-Year Transit Development Plan (TDP) 2020-2029, branded Bus Plus, was prepared by the TPO in cooperation with the County. The Bus Plus plan represents the community's vision and goals for public transportation and is the guide for a 10-year planning horizon.

At the time of this effort, a Major Update to the TDP was underway. The update includes a baseline assessment of the existing transit system and the integration of regional passenger rail service. To assess the potential of a Fort Pierce Passenger Rail station, staff used integrated planning and scheduling software to create a data visualization to understand how the service would integrate with the existing network. This analysis includes ridership potential, economic and demographic information, proximity of the proposed station, and intermodal connections with the local and regional transit systems.



The analysis was created to include overlay information from the Indian River County (Go-Line) routes and the Martin County (Marty) routes, and the Palm Beach, Broward, and Miami-Dade existing Brightline stations were also included in the analysis.

Downtown Fort Pierce Master Plan

The City adopted the Downtown Master Plan in November 2022 which strategically identifies significant growth and opportunities for the future of Downtown Fort Pierce. Fort Pierce offers location, historic character, waterfront accessibility, and affordability. The confluence of these attributes place the City in prime position to capitalize on 21st century development trends to revitalize the Downtown. The revitalization strategy includes the development of a passenger rail station in the Downtown.

The Master Plan reiterates that the City is well positioned for rail service as it is close proximity to the metro areas of Orlando, West Palm, Fort Lauderdale, and Miami; all located within 130 miles, and which could be connected via regional passenger rail service, with a Downtown Fort Pierce Station.

The Plan documents that Downtown is a destination that is developing at a comfortable pedestrian-oriented scale that is generally focused on the waterfront. Capital investments in the waterfront and special event programming have made Downtown Fort Pierce a compelling place to visit. Planned and programmed mixed-use and residential projects will increase the full-time resident ratio in the Downtown district and will increase economic and resident activity which is supportive of passenger rail service.



The 2021 Retail Strategic Plan identified a Tier One and Tier Two list of targeted potential retail tenants for Downtown Fort Pierce that are based on the Retail Market Analysis and Demographic evaluation. These targeted retail sectors include cultural, entertainment, and hospitality type uses that attract residents and appeal to visitors and tourists. These sectors include art galleries, brew pubs, restaurants, and experiential retail. With greater population and disposable income available in the 10 and 15-minute drive areas, improving Downtown Fort Pierce as an attractive waterfront destination could spur redevelopment across a variety of industry sectors. **Figure 4** on the following page compares the Existing Future Land Use at the time of the Master Plan Development in comparison to the Recommended Future Land Use plan which shows significant increases in development and density.

2023 Fort Pierce Strategic Plan

The City of Fort Pierce prepared an update of their Strategic Plan in August of 2023. The plan encompasses a range of key areas such as economic growth, infrastructure enhancement, community engagement, and environmental sustainability. Key highlights include initiatives to revitalize downtown areas, promote job creation, invest in infrastructure projects, enhance public safety, and preserve the city's natural resources. and businesses. The plan specifically addresses this Passenger Rail Station/Mobility Hub and Station Concept Plan

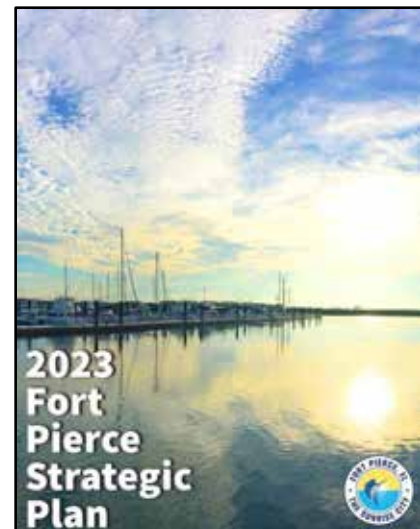

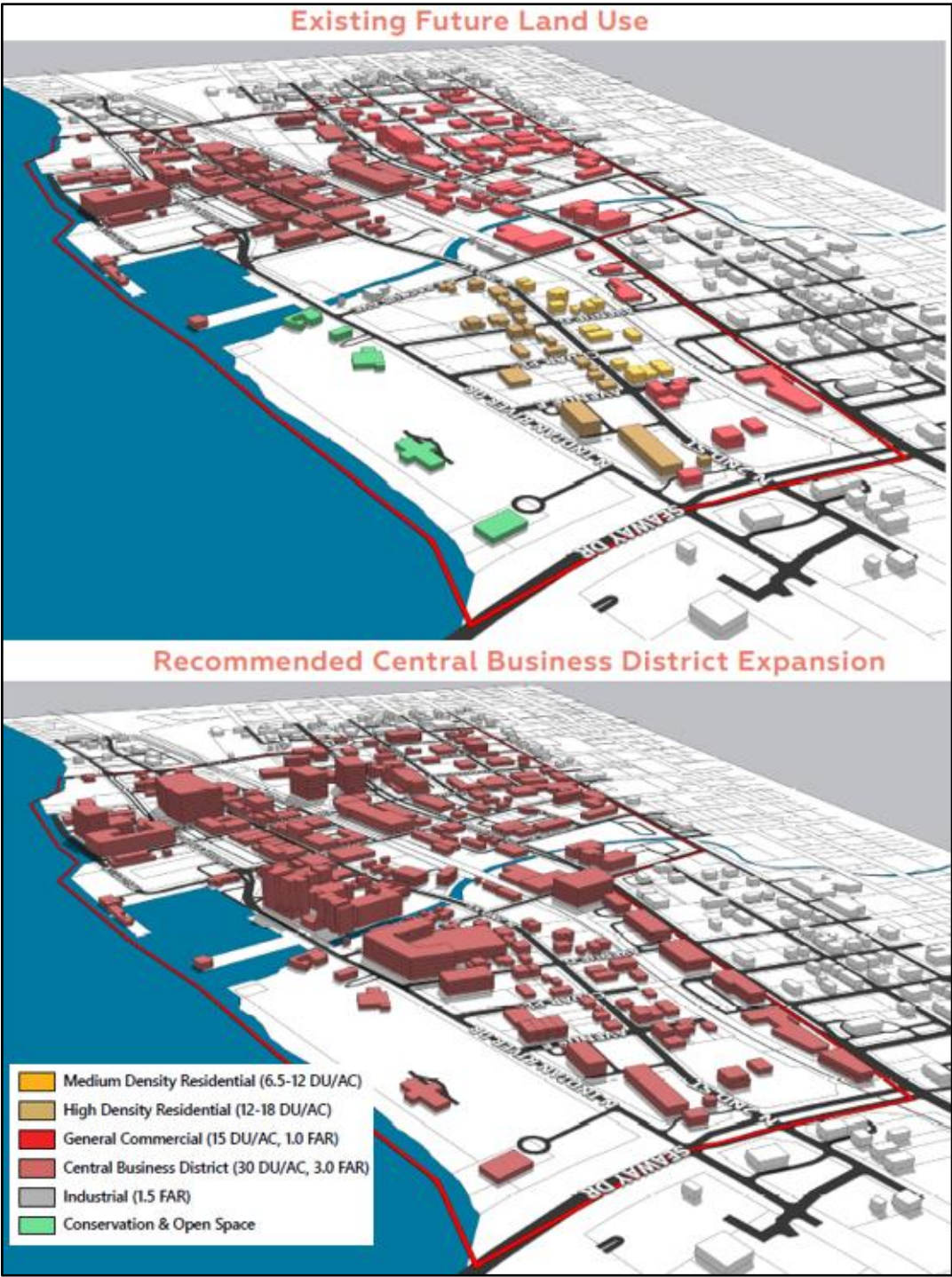

Figure 4: Downtown Master Plan Existing and Recommended CBD Land Use and Density



St. Lucie TPO Micro-Mobility Study

The St. Lucie TPO Micro-Mobility Study reviews the needs and characteristics of various low-speed transportation options, compares them to existing conditions in the transportation network, land development patterns and demographics for three distinctly different study areas including the Downtown area and develops considerations that the St. Lucie TPO can implement or coordinate to promote more widespread and greater density of micro-mobility options throughout St. Lucie County.

The final recommendations for Downtown include:

- Support expanded shared scooters
- Implement Zoning to require bike and scooter racks in new construction.
- Implement Buffered Bike Lanes:
 - N/S 13th Street from Canal to Virginia Avenue to Avenue Q
 - Avenue D from N 13th Street to US-1
 - Delaware Avenue from S 13th Street to US-1
- Bike racks and suitable scooter racks per the TPO Bike Rack Plan, at schools, and transit stops
- Public information for transit policies for scooter and bike

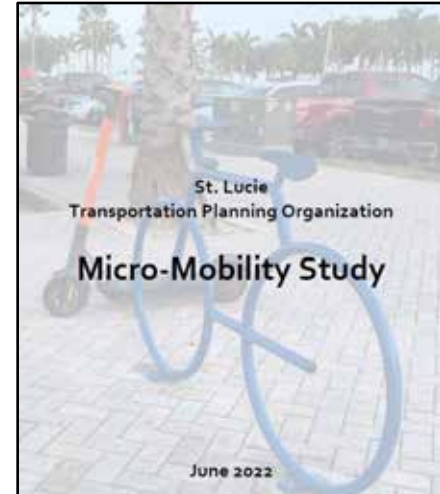



Chapter 2. Access and Connectivity

Downtown Fort Pierce

Fort Pierce Multimodal Connectivity

Downtown Fort Pierce provides various multi-modal resources for its residents, workers, and visitors. The City is located near the junction of I-95 and the Turnpike on the west side of the City making it an ideal “milepost” for tourists or commuters. It is also served by the Treasure Coast International Airport which is just over three (3) miles north of the Fort Pierce Redevelopment Area (FPRA), and the Port of Fort Pierce is located within the FPRA. The St. Lucie ART transit system has a centralized transportation bus transfer center at the Fort Pierce Intermodal Terminal located a couple of blocks west of Downtown. The terminal serves multiple routes providing access across the county. Downtown Fort Pierce also provides access to microtransit and micromobility options as St. Lucie ART provides a new on-demand microtransit service (Freebee Pilot Program) connecting downtown to the barrier island. In addition, there is a comprehensive network of sidewalks and some multi-modal greenways accessible to pedestrians and bike users.

Downtown Fort Pierce is poised to continue growing sustainable modes of transportation, and future plans to improve multi-modal infrastructure in Downtown are also underway. The St. Lucie TPO 2045 LRTP and ACES study; the County TDP and The City Downtown Master Plan are all robust planning documents setting the course for a more vibrant and connected Downtown Fort Pierce. The following sections summarize Fort Pierce’s existing multi-modal resources including regional and local traffic, public transit, microtransit, and pedestrian/bicycle/micromobility connectivity. In summary, existing conditions and local planning documents build a case for Downtown Fort Pierce to establish a passenger rail station and mobility hub.

As previously mentioned, the Project Team identified three (3) sites to assess as a potential location for a passenger rail station and ACES mobility hub. All three (3) locations are in the Downtown Core and along the FEC railroad tracks. **Figure 5** shows the location of the sites in proximity to major employment locations. Due to the sites being so close together, they enjoy many of the same opportunities and advantages for the development of the rail station and hub. The entire proposed area is very walkable and connected by a grid of local streets and sidewalks and benefits from robust access to the regional transportation network.



Figure 5: Three Selected Sites and Proximity to Key Employment Centers

Train Station Trip Generation and Roadway Connectivity

A trip generation analysis was performed to determine station traffic impacts. Rates and equations from the *Institute of Transportation Engineers (ITE) Trip Generation Manual, 11th Edition* Land Use Code for a Park-and-Ride Lot with Bus or Light Rail Service were used to estimate the volume of traffic that could be accessing the train station. The ITE reports are included in **Appendix A**. The net projected trips are 648 daily with 125 trips in the morning and 126 trips in the afternoon. Note that these are very conservative estimates and should be included in the framework of a long-term need.

Annual Average Daily Traffic (AADT) data for 2023 was extracted from the TPO Traffic Counts and Level of Service (LOS) Report. The LOS Report provides data and analysis of roadway conditions from A to F from the 2020 FDOT QLOS handbook. **Figure 6** shows the peak season traffic around the study area is performing very well at LOS C and D with capacity available for redevelopment.



Figure 6: AADT and Level of Service (LOS) Map

Traffic data and analysis were also developed for regional roadway connectivity between I-95 and the Turnpike to Downtown Fort Pierce. 2023 data was extracted from the TPO LOS Report. **Figure 7** shows the peak season regional traffic on Orange Avenue and Okeechobee Road operating mostly at LOS C which indicates good accessibility by roadway to and from Downtown.



Figure 7: Regional Access AADT and Level of Service (LOS) Map

Crash History

A crash history analysis was performed in the area, with the purpose of identifying high-risk areas in the city. Understanding crash data provides insights into the safety needs and challenges of the area surrounding the potential station. Crash data can help identify patterns or trends in accidents involving various modes of transportation, including automobiles, pedestrians, and cyclists. This information is crucial for designing safe access points to the train station and warranting seamless integration with other modes of transportation, as it aligns with broader goals of promoting safety and reducing traffic-related injuries and fatalities.

Crash data from January 2018 to December 2022 within the Downtown area was downloaded from Signal Four Analytics (S4). Based on the crash data, crash summaries were prepared for the five years. Based on the crash data reviewed, 703 crashes were documented in Downtown with 146 crashes in 2018, 149 crashes in 2019, 134 crashes in 2020, 129 crashes in 2021, and 145 crashes in 2022. Based on crash severity, of the 703 crashes reported, 137 (19%) were injury-type crashes, and 564 (80%) were property damage-only crashes. Of the 137 injury crashes, eight (8) of them were severe injuries. Two (2) fatal crashes were reported during the referenced five (5) year period. One of the crashes is a vehicle-to-vehicle head-on collision and the second one is a vehicle to pedestrian collision. The crash data and police reports for the two fatalities are attached in **Appendix A**. Note that the City of Fort Pierce was awarded a Safe



Streets 4 All grant to prepare a Vision Zero Action Plan that will be underway shortly with the intent of achieving zero serious injuries and fatalities.

St. Lucie ART Connections

Downtown Fort Pierce is serviced by the St. Lucie ART Routes 1, 2, 3, 7, and 8. **Figure 8** shows the ART local bus system clearly showing that Fort Pierce is a hub of operations. A description of each route accessing Downtown follows.

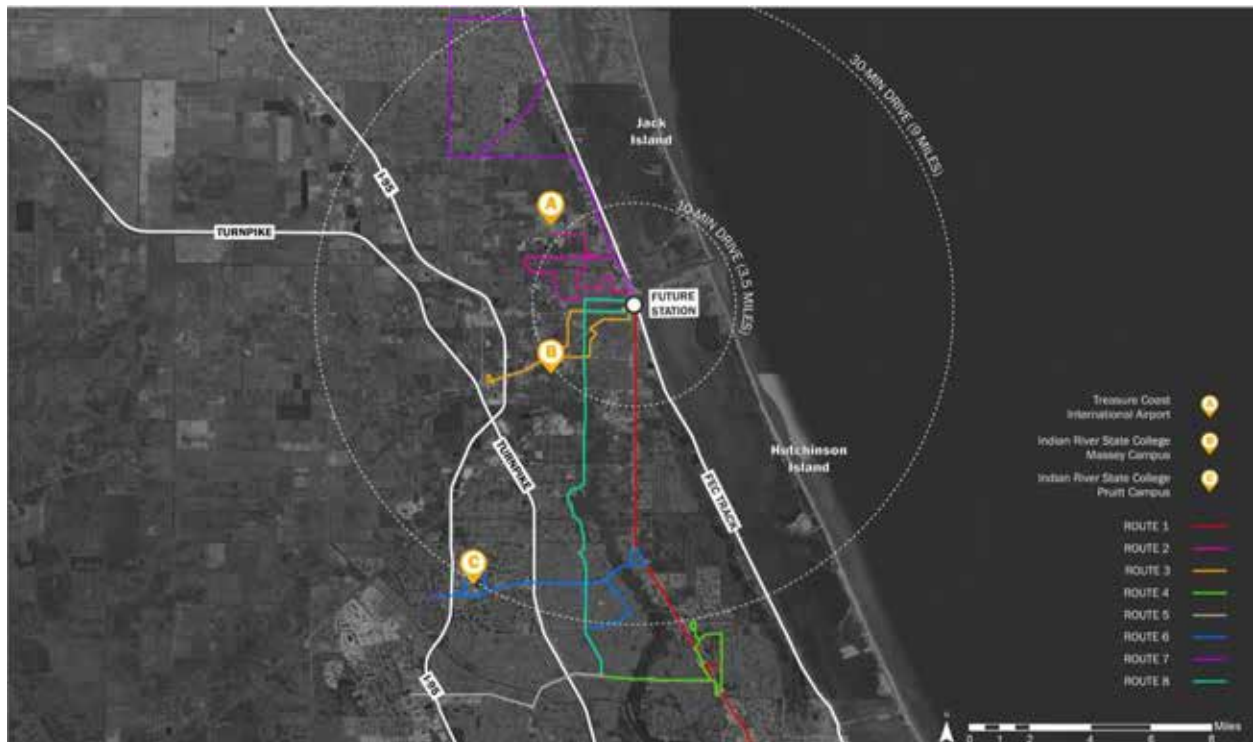

Figure 8: St. Lucie Area Regional Transit (ART)

Route 1 (Treasure Coast Connector) has a fixed northbound-southbound schedule, with hourly headways, running from 6:00 am to 8:00 pm on weekdays and 8:00 am to 4:00 pm on Saturdays. The route primarily runs along US 1 in the southern sections of Fort Pierce and has 20 total stops. The route is regional as its southern terminus is at the Treasure Coast Mall in Martin County connecting to the Fort Pierce Bus Terminal to the north.

Route 2 has a fixed eastbound-westbound schedule, with hourly headways, running from 6:00 am to 8:00 pm on weekdays and 8:00 am to 4:00 pm on Saturdays. The route primarily runs on local roadways in the north/northwest sections of Fort Pierce and has 15 stops. The route begins at A1A & US 1 and ends at the Fort Pierce Bus Terminal.



Route 3 has a fixed northbound-southbound schedule, with hourly headways, running from 6:00 am to 8:00 pm on weekdays and 8:00 am to 4:00 pm on Saturdays. The route primarily operates in the south/southwest sections of Fort Pierce and has 13 stops. The route begins at Okeechobee Road and Peters Road and ends at the Fort Pierce Bus Terminal.

Route 7 has a fixed northbound-southbound schedule, with hourly headways, running from 7:00 am to 6:00 pm Monday through Friday. The route primarily runs along US 1 and Indrio Road in the northern section of Fort Pierce and has 6 stops. The route begins at Oslo Road at SW 15th Avenue and ends at the Fort Pierce Bus Terminal.

Route 8 is an Express Route with a northbound-southbound schedule, with hourly headways, running from 7:00 am to 7:00 pm on weekdays only. The route primarily runs along Airosa Boulevard in the southern section of Fort Pierce and has 12 total stops. The route begins at SE Deacon Avenue at SE Belvedere Street and ends at the Fort Pierce Bus Terminal.

MicroTransit Connectivity

In addition to ART bus routes, the FPRA provides for a Freebee on-demand microtransit program in downtown Fort Pierce and the City of Fort Pierce provides a downtown circulator service called the Fort Pierce Tram.

Freebee - Fort Pierce currently benefits from a public-private partnership between the FPRA and Freebee. Freebee's on-demand service is available from 10:00 am to 8:00 pm on Thursdays and Sundays and till 10:00 pm on Fridays and Saturdays. Users of the service can



enjoy free, door-to-door service anywhere within the FreeBee service area. The service area currently encompasses downtown Fort Pierce, across the Seaway Drive South bridge, to the beachside. Significant destinations within the service area include Sunrise Theatre, St. Lucie County Aquarium, and Jetty Park.

The **Fort Pierce Tram** has a fixed downtown circulator schedule, with 15-minute headways, running from 5:00 pm to 9:00 pm on Fridays and 8:00 am to 3:00 pm on Saturdays. The route services the downtown area with a total of 5 stops. The route begins at City Hall/Parking Garage and ends at the Marina Square.

Figure 9 shows the Tram stops.



Figure 9: Fort Pierce Tram Stops

Pedestrian Bicycle/Micromobility Connectivity

Regarding non-motorized/micro-mobility activity, a multi-use path exists along the downtown Riverwalk from Seaway Dr. to the Manatee Observation and Education Center and there are plans to extend the multi-use path shared in the Downtown Fort Pierce Master Plan.

The St. Lucie Micro-Mobility Study recommends for Fort Pierce that micromobility accessibility can be further improved in the Downtown Area with infrastructure enhancements such as buffered bike lanes, additional bike/scooter parking, and wayfinding/information signage along downtown corridors such as NE 13th St., Avenue D, and Delaware Ave. **Figure 10** shows the recommended micromobility plan for the Downtown area.

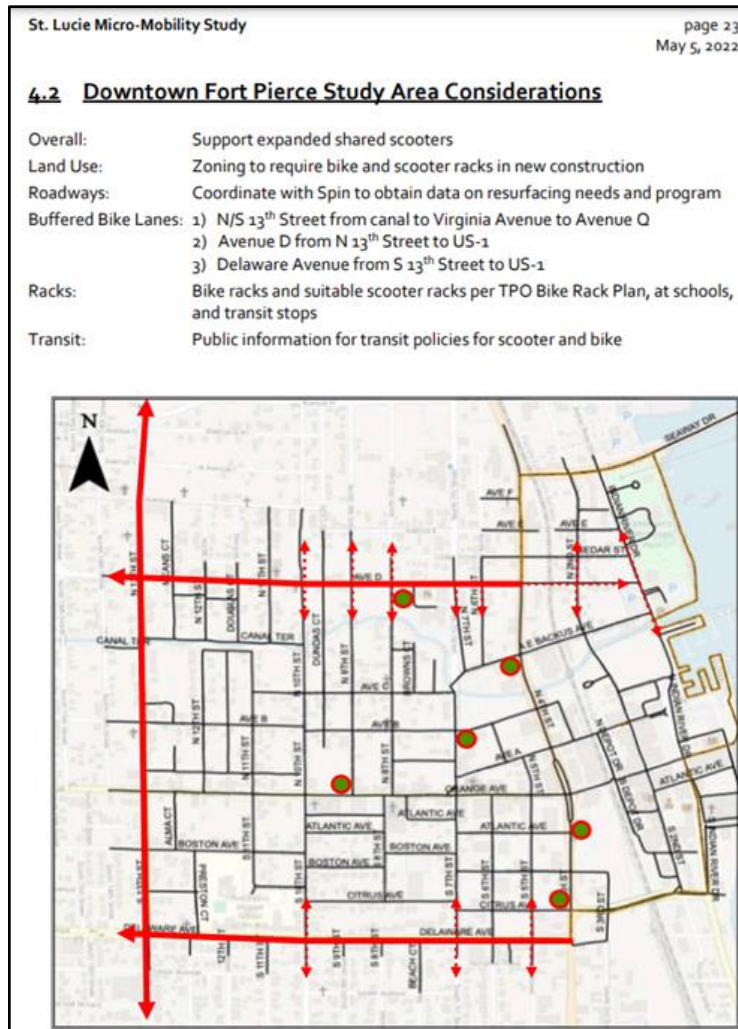

Figure 10: Downtown Fort Pierce Micromobility Recommendations

In 2023, FDOT, the City of Fort Pierce and the St. Lucie TPO successfully partnered to have a continuous bicycle and pedestrian count station added to the Fort Pierce South Bridge. The count station provides high-quality bicycle/pedestrian/micromobility traffic data for non-motorized/micromobility travelers crossing the south bridge, 24 hours a day, seven (7) days a week, 365 days a year. FDOT’s Transportation Data and Analytics (TDA) Office currently manages the continuous bicycle and pedestrian count station on Seaway Drive and South Causeway Beach, adjacent to downtown. According to the latest 2024 figures provided by FDOT’s Statewide Non-Motorized Traffic Monitoring Program, the count station averages 3,363 non-motorized/micromobility travelers traversing the causeway per month. See existing mode share volumes in **Figure 11**.



Figure 11: 2024 Non-Motorized/Micromobility Monthly Traffic Totals, per mode

According to the City of Fort Pierce Downtown Master Plan, the city intends to enhance pedestrian/bicycle infrastructure throughout the downtown area to improve safety and promote economic vitality. The plan references the addition of Festival Streets, Linear Parks, Riverwalk, and Waterfronts District as some of the primary goals for downtown Fort Pierce. *“The Waterfront District will link River Walk Park to a newly created Marina Park and connect to the commercial heart of Downtown between Avenue A and Orange Avenue with walkable streets.”* Intersection improvements such as US 1 at Avenue A and roadway improvements to Indian River Drive will improve safety and connectivity and serve as a gateway into the downtown area, all of which support the connectivity to a passenger rail station and mobility hub in Downtown Fort Pierce.

Florida East Coast Greenway and SUNTrail

A Downtown Fort Pierce passenger rail station is also recognized as a central hub of the St. Lucie County East Coast Greenways plan that shows the potential passenger station as a key destination that will be connected, or in close proximity, to the East Coast Greenway, FDOT Shared Use Network Trails (SUNTrail) Program and the Treasure Coast Loop. **Figure 12** shows a map of the status of each segment.

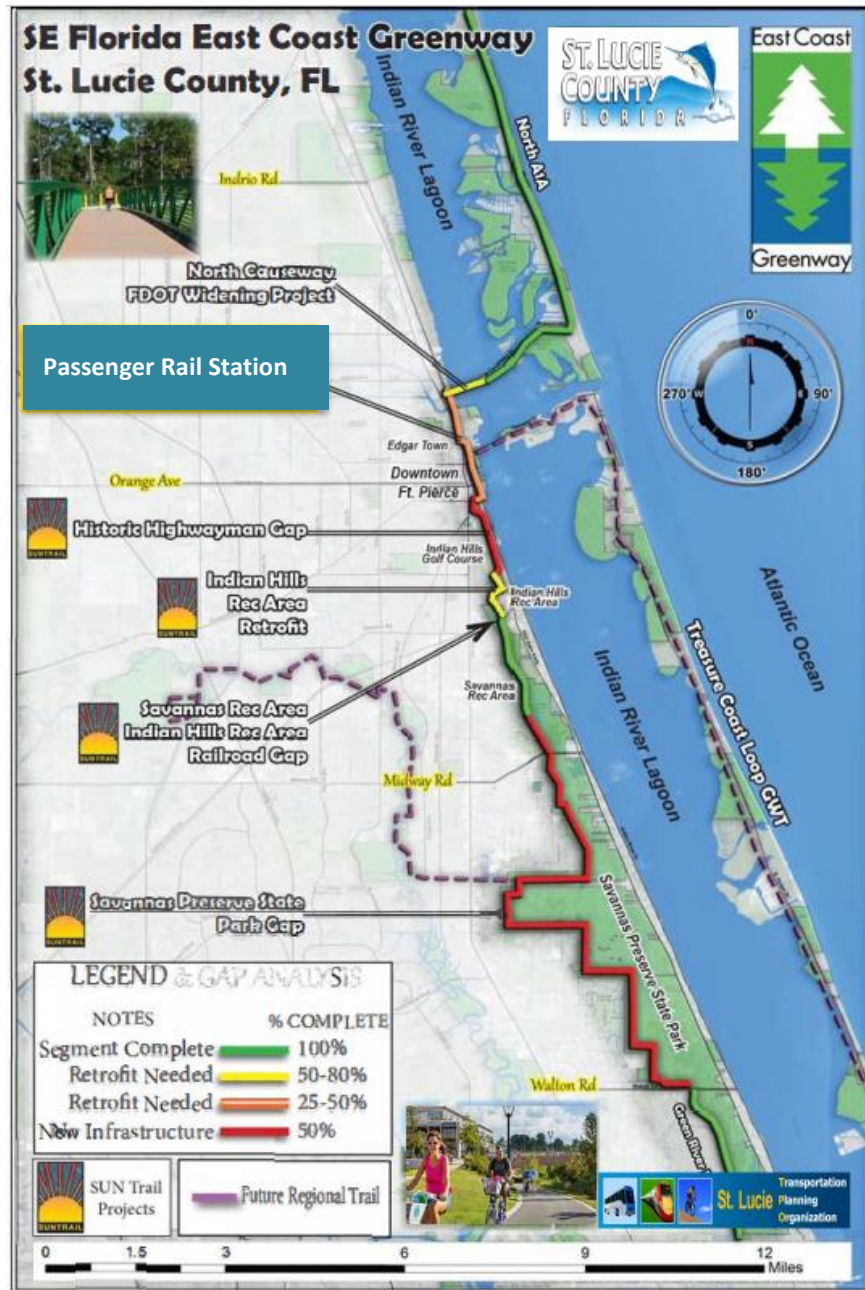

Figure 12: St. Lucie County East Coast Greenway



Chapter 3. Station Area Planning

As indicated in Chapter 1. Introduction, three (3) alternative sites were identified by the Project Team for evaluation of a regional passenger rail station/mobility hub based on factors including size and redevelopment potential. The mobility hub aspect holds significant importance as it will establish a centralized node for pedestrian, bicycle, and trail access, as well as for motorized, Autonomous, Connected, Electric, and Shared (ACES) technologies, and micro-transit, all situated at a prominent location.. The mobility hub could also be implemented in advance of a rail station to continue building synergy for passenger rail by being designed with an envelope for station operations and a passenger platform.

The proposed three (3) locations, identified by the City of Fort Pierce and the TPO, for evaluation include:

- **Audubon Development Inc./H.D. Kings Landing Site:** Parcel #2410-503-0034-000-6 plus the adjoining parcels also owned by Audubon Development Inc.
- **Boston Avenue Site:** Parcel #2410-701-0002-000-1 plus the adjoining parcels also owned by FEC. These are south of Orange Avenue between the tracks and US 1.
- **Depot Drive Site:** Parcel #2410-805-0005-010-4 which is south of Orange Avenue, on the east side of the tracks, and is owned by the City of Fort Pierce.

The sites were selected as early candidates for a passenger rail station; however, these selections do not preclude future consideration of other site(s) in Fort Pierce. A brief summary of each proposed site is provided below and shown on **Figures 13 and 14**.

Audubon Development/H.D. King's Landing Site

- The 7.2 acre parcel is part of the H.D. King Plant Site a Mixed-Use Development by Audubon Development
- Waterfront property across from Fort Pierce City Marina in Downtown Fort Pierce
- Located adjacent to the FEC railroad
- Zoning - former Light Industrial, now Approved Planned Development

Boston Avenue Site

- 7.02 acres parcel
- Situated on the western side of the FEC rail right of way, just south of Orange Avenue
- Owned by FEC and adjacent to the FEC railroad
- Parcel is currently zoned C-4 - General Commercial Zoning and PD - Planned Development

Depot Drive Site

- 0.90 acres parcel fronting FEC, expanded to 2.47 acres with County and private property
- Situated on the eastern side of the FEC rail right of way directly, behind the Sunrise Theatre
- Owned by the City of Fort Pierce, St. Lucie County and Private Property owner

- It is currently utilized for surface parking, however, a large portion of it is undeveloped
- Parcel is currently zoned C-4, Central Commercial Zoning

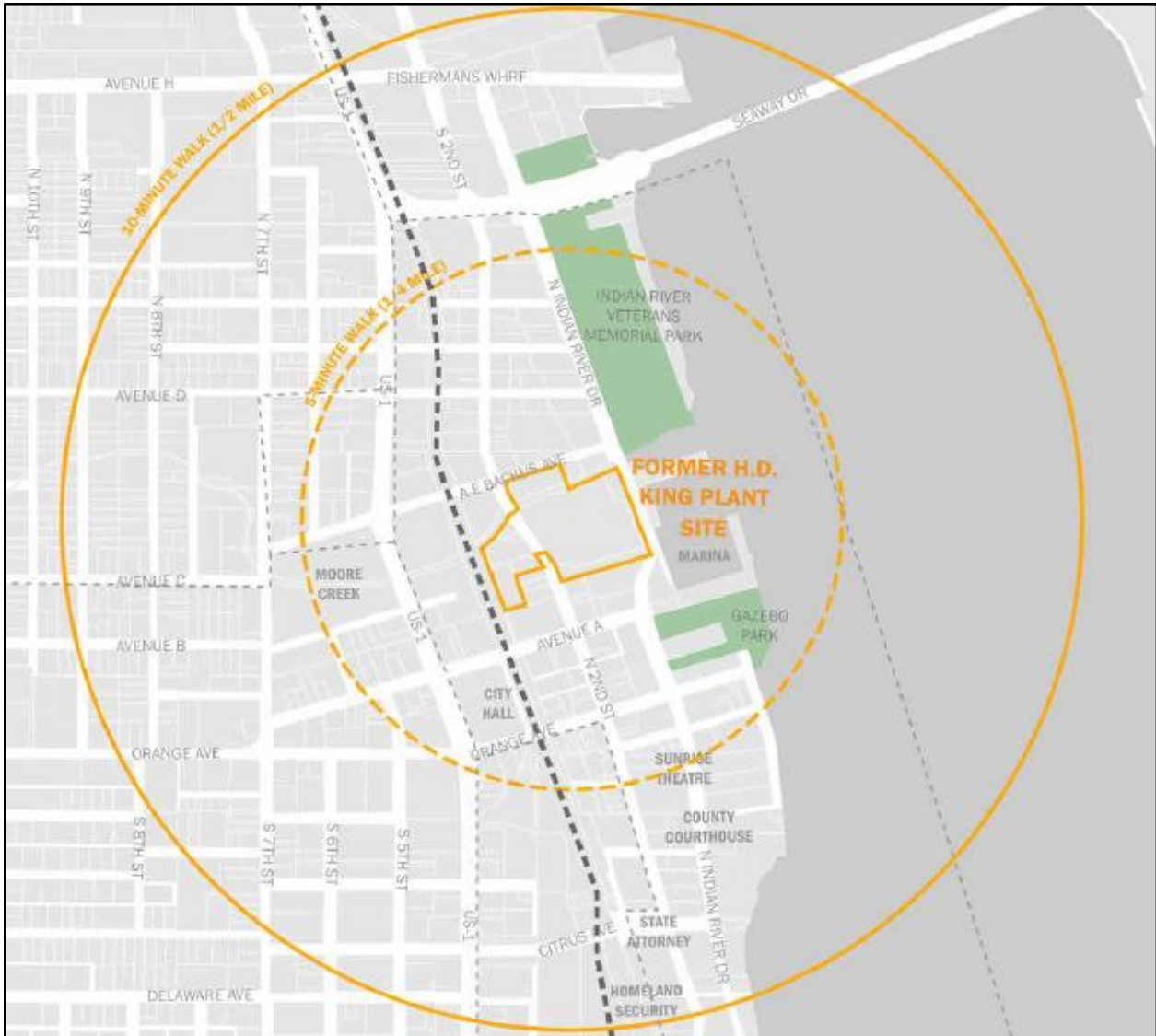

Figure 13: Audubon Development Site

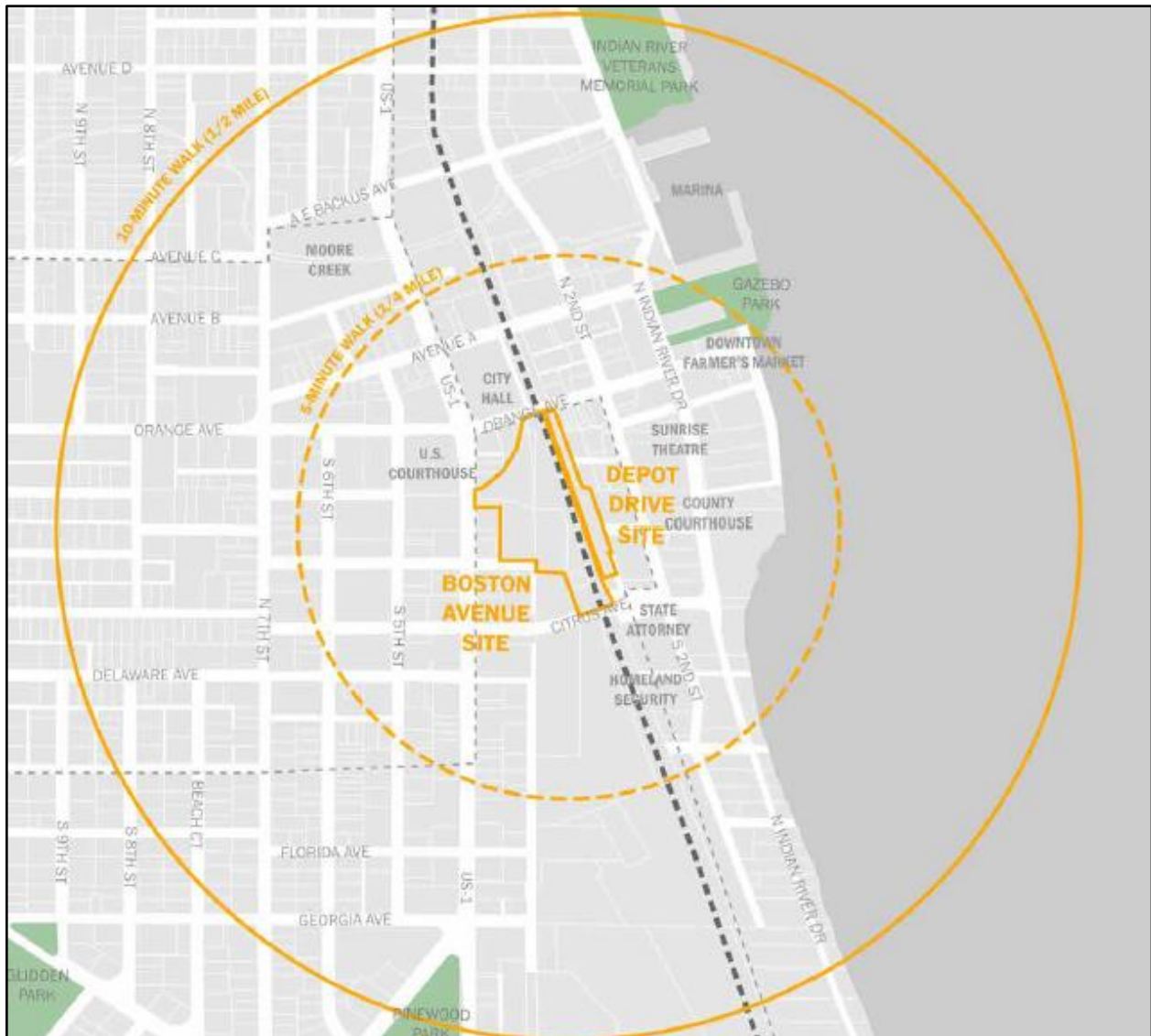

Figure 14: Boston Avenue and Depot Drive Sites

Audubon Development/King’s Landing Site

Nestled within downtown Fort Pierce, Florida, lies the Former H.D. King Plant Site, a 7.2-acre parcel with the potential to undergo a transformation into a pivotal nexus of mobility and community engagement. As part of the ambitious King's Landing mixed-use development by Audubon Development, this site, once zoned for light industrial use, is now an Approved Planned Development, and holds the potential of becoming a dynamic passenger rail station and mobility hub. The site has been approved for 232



residential units, 140 hotel rooms, and 52,000 square feet of retail space, and its waterfront location across from the Fort Pierce City Marina presents an enticing prospect for travelers, businesses and residents alike. Situated along the FEC tracks, the station capitalizes on existing infrastructure, fostering seamless connectivity within the city and beyond. Moreover, its strategic proximity to the Indian River Veterans Memorial Park and Gazebo Park, as well as the Moore's Creek Linear Park and Greenway, ensures accessibility and integration with surrounding recreational spaces. Additionally, the City's plan for a linear greenway along the rail corridor promises to enhance pedestrian and bicycle connectivity, bridging disparate neighborhoods and fostering a sense of cohesion within the community. Despite the inherent challenges of repurposing former industrial land, the development of this mobility hub represents a unique opportunity to not only revitalize the urban landscape but also to cultivate a more sustainable and interconnected future for Fort Pierce.

In preparation for the Brightline proposal advertisement, Indian River State College (IRSC) was coordinating with site owners for a potential public-private partnership with IRSC and its foundation. In correspondence to the FEC, the IRSC Office of the President was promoting a collaboration including a station, a new Culinary School, dining facilities with a kitchen highlighting IRSC's culinary program, a museum featuring the art and history of the Treasure Coast, and luxury apartments. A conceptual layout of the proposal provided in **Figure 15**, and **Figure 16** shows the proposed full development including the King's Landing concept.

Opportunities:

- 7.2 acres available for development
- Located adjacent to the FEC tracks
- Waterfront property across from Fort Pierce City Marina in Downtown Fort Pierce
- Approved private development: King's Landing Mixed-Use Development
- Strategic proximity to the Indian River Veterans Memorial Park, Gazebo Park, and the Moore's Creek Linear Park and Greenway
- Ability to enhance pedestrian connectivity by connecting the station to the neighborhoods by a potential linear greenway
- Potential Collaboration with IRSC for a Culinary School and Treasure Coast Museum

Challenges:

- Repurposing former industrial land can have environmental concerns
- Platform length
- Proximity of site to Moore's Creek present environmental regulations, flood risk, and habitat protection concerns.



- The City of Fort Pierce tapped Audubon in June 2019 to develop the site, but there has been limited progress in the development of the site.

Passenger platform length and the impacts of trains closing streets when boarding and alighting passengers will be critical factors in site selection. The Kings Landing site can only accommodate a 500' max platform length. Note that bridging over the existing canal to the north is challenging and costly and would need to address issues related to waterway rights and approvals through the Army Corps and other owners (or city or county ownership). This location may also require a standalone track next to the new platform and therefore would need a new 'spur' alignment which is challenging to accommodate at this location. The issue is more complex when considering what passenger rail service will be provided as Brightline, Tri-Rail, and Amtrak operate different types of trains, and as a result, their platform lengths can vary:

- Brightline operates high-speed trains. The typical platform length for Brightline is around 600 feet however they requested 500 to 1000 feet in the recent RFP.
- Tri-Rail operates commuter trains in South Florida. Tri-Rail platform lengths vary but are typically around 400 to 500 feet long.
- Amtrak operates various types of trains, including high-speed, long-distance, and commuter trains. The platform lengths for Amtrak vary greatly depending on the station and the type of service it provides. For long-distance trains, Amtrak platform lengths can range from 600 to 1,000 feet or even longer. For commuter trains like those operating on the Northeast Corridor, Amtrak platform lengths are generally around 800 feet long.

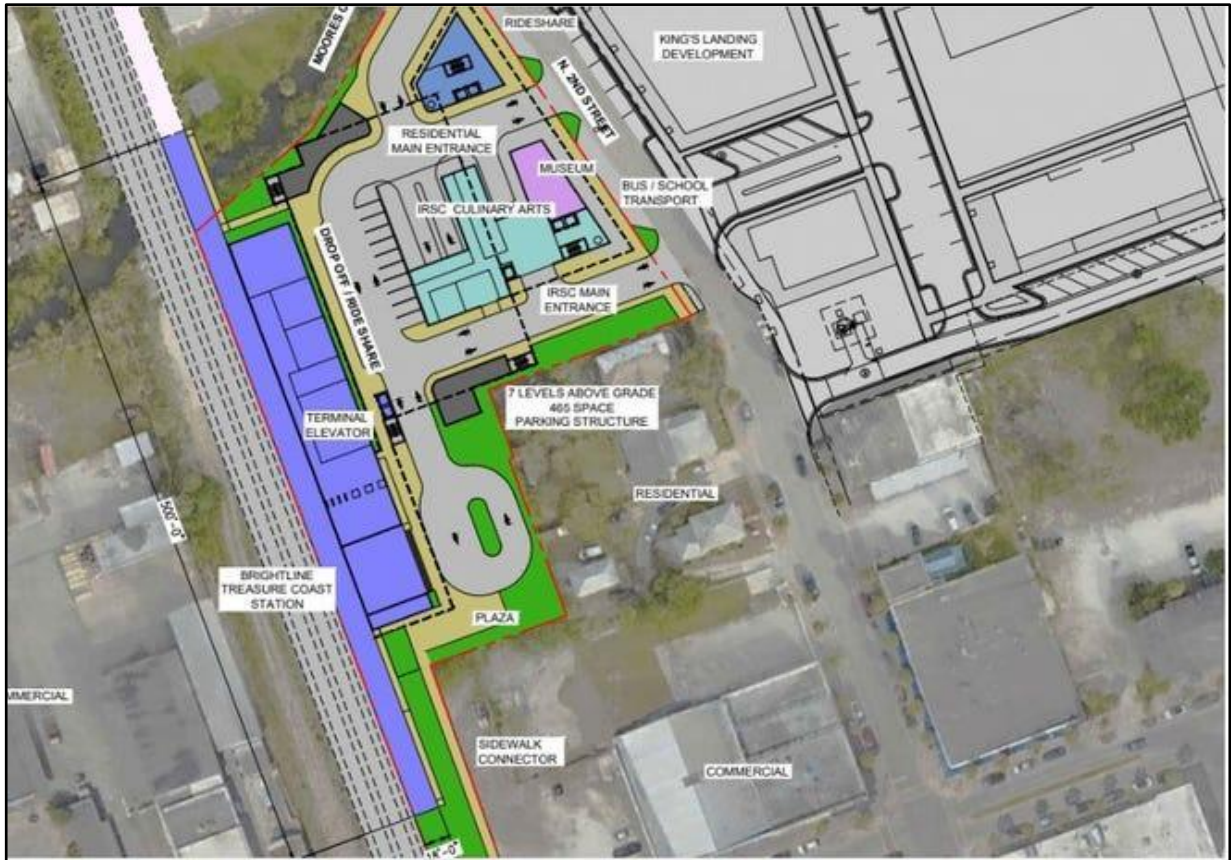

Figure 15: IRSC Rendering of Passenger Rail Station and Culinary School



Figure 16: Potential Audubon Development/King's Landing Development Concept

Boston Avenue Site

On the Western side of the FEC rail right of way, and South of Orange Avenue, the Boston Avenue Site emerges as another option for a passenger rail station and mobility hub in Fort Pierce. Boasting a sprawling 7.02-acre parcel owned by FEC and currently zoned for General Commercial and Planned Development, this site harbors the potential for transformation into a hub of connectivity and community engagement. With plans for a Transit-Oriented Development (TOD) offering 182 residential units, alongside substantial office and retail space, the site stands as a potential for integrated urban development. The envisioned Civic District, bolstered by nearby Gazebo Park and Marina Park, increases its attraction even further by encouraging a thriving mix of business and civic engagement. The site would also connect the City's planned linear greenway along the rail corridor, as planned in the Downtown Master Plan, to seamlessly integrate surrounding residential areas, as well to the future ambitious Audubon Development/King's Landing. The most significant differentiator for this site is direct access and visibility from US 1, the most heavily trafficked corridor in Downtown. One primary challenge with this site is that it is owned by FEC, which is unwilling to engage in negotiations for the purchase of the property.



The Downtown Master Plan shows a Vision Plan including the development of a Passenger Train Station at the Boston Avenue site shown in **Figure 17**.



Figure 17: Downtown Master Plan 10+ Years Development - Brightline Station (#2) at Boston Ave Site

Opportunity Characteristics are that the Boston Avenue site has high visibility with 24,609 AADT on US 1 and approximately 350 linear feet along US 1 and is adjacent to the FEC railroad tracks. The site also has benefits including flexible retail zoning in place, TOD opportunities and Potential Retail Uses including; neighborhood center, single tenant freestanding retail, strip & convenience center and mixed use/commercial. The site would require multiple parcel assemblages and the Boston Avenue intersection at US 1 is unsignalized.

Opportunities:

- 7.02 acres available for development.
- Located on FEC tracks.
- Owned by FEC
- Direct access from US 1
- Parcel is zoned as C-4 and Planned Development.
- FEC Owned TOD Potential Opportunity
- Gazebo Park and Marina Park within a 5-minute walk.
- Enhance pedestrian connectivity by connecting the station to the neighborhoods by a potential linear greenway.
- Located close to the Festival Streets.

Challenges:

- Has an irregularly shaped lot
- The owner is an unwilling participant



Depot Drive Site

Depot Drive Site is located on the Eastern side of the FEC rail right-of-way, adjacent to the iconic Sunrise Theatre, and is a 1.55-acre parcel with the potential to serve as a transformative passenger rail station and mobility hub in Fort Pierce. The site is owned by the City of Fort Pierce and currently serves as surface parking. The current zoning is C-4 Central Commercial, and a significant portion lies undeveloped. Gazebo Park and Marina Park are both within a five-minute walk, and the site benefits from a strategic location primed for synergy with the city's vibrant recreational and cultural spaces. Furthermore, the adjacent County-owned site provides for additional redevelopment opportunities. The County site is envisioned in Fort Pierce's Downtown Master Plan as a catalyst site to be redeveloped with 92 residential units and extensive office and retail space. Festival Streets initiatives aimed at enhancing connectivity and walkability along key corridors, including 2nd Street, underscore the city's commitment to fostering a conducive environment for redevelopment. Moreover, plans for a linear greenway along the rail corridor promise to bolster connectivity with residential areas, as well to the future King's Landing mixed-use development by Audubon Development, amplifying accessibility and community integration. Though beset with the challenges inherent in repurposing urban land, the Depot Drive Site represents a beacon of opportunity, poised to catalyze sustainable growth and connectivity within Fort Pierce's urban fabric.

A green promenade is planned to connect pedestrians from Citrus Avenue along Depot Drive up to Backus Avenue towards the north. This Promenade/Paseo is a crucial public space improvement for the area that will allow pedestrians and bike users to connect and mobilize safely around the downtown area. **Figure 18** shows the Downtown conceptual layout.

Opportunities:

- Located on FEC tracks
- Owned by the City of Fort Pierce and adjacent to County owned land
- Gazebo Park and Marina Park within a 5-minute walk
- Enhance pedestrian connectivity by connecting the station to the neighborhoods with a potential linear greenway
- Located close to the Festival Streets

Challenges:

- Small/narrow site
- Access to local streets



Figure 18: Downtown Fort Pierce Green Promenade (Paseo)

Downtown Fort Pierce Development Potential

Looking ahead, St. Lucie County continues to experience robust development, marked by the construction of 985 multifamily rental units, 210,000 square feet of retail space, and 30,000 square feet of office space.

Amidst this ongoing growth and demand for development in St. Lucie County, the City of Fort Pierce has strategically positioned itself for expansion, particularly in its Downtown core. Guided by the Downtown Master Plan, the city envisions comprehensive infrastructure improvements, capital investments, enhanced mobility, and vibrant place-making initiatives to support substantial investments in large-scale mixed-use projects.

This new development will complement and support the development of a passenger rail station and mobility hub within a TOD area along the FEC corridor including the three (3) sites selected for this study. **Figures 19, 20, and 21** show existing mid and longer-term development scenarios from the Downtown Master Plan in proximity to the sites.



Figure 19: Three Sites & Existing Development Scenario



Figure 20: Three Sites & Mid-Range (Present to 10 Years) Development Scenario



Figure 21: Three Sites & Long-Range (10 Plus Years) Development Scenario



Chapter 4. Station Area Concept

Brightline RFP

On October 26, 2023, Brightline announced that it was seeking proposals from public and private entities to identify a station location for its Treasure Coast station. The RFP identified specific criteria that needed to be met for an application to be competitive including a requirement that only proposals from current property owners and those that have property under contract will be considered. The RFP also had a short timeline, due by December 22, 2023.

At this point, the Project Team pivoted to take advantage of an immediate opportunity to land a passenger rail station with intercity service in Fort Pierce. As a result, the Depot Drive Site was selected as the best opportunity because the City and the County owned the land for the station area. **Figure 22** shows photos of existing conditions at the site.



Figure 22: Depot Drive Existing Conditions Photos

The Depot Drive Site currently serves multiple purposes, including a surface parking area situated at the rear of the historic Sunrise Theatre, in addition to two single-story retail buildings and the County parking garage. The proposed plan involved relocating the public surface parking in addition to preserving and expanding the County parking garage as a crucial component of the site's upcoming redevelopment. Once the Team began to lay out the station area site plan, it became necessary that the site would have to



include a small privately owned parcel to make the internal traffic circulation work. **Figure 23** shows the parcel layout, size, and ownership.

Two(2) City of Fort Pierce parcels total 1.23 acres and are dedicated to the development of the station, platforms, circulation, and station access. A private partner owns the third parcel and has provided a willing seller letter to the City (**Appendix B**). The City of Fort Pierce committed to acquiring the privately owned 0.32-acre parcel and seamlessly integrating it into the station plan.

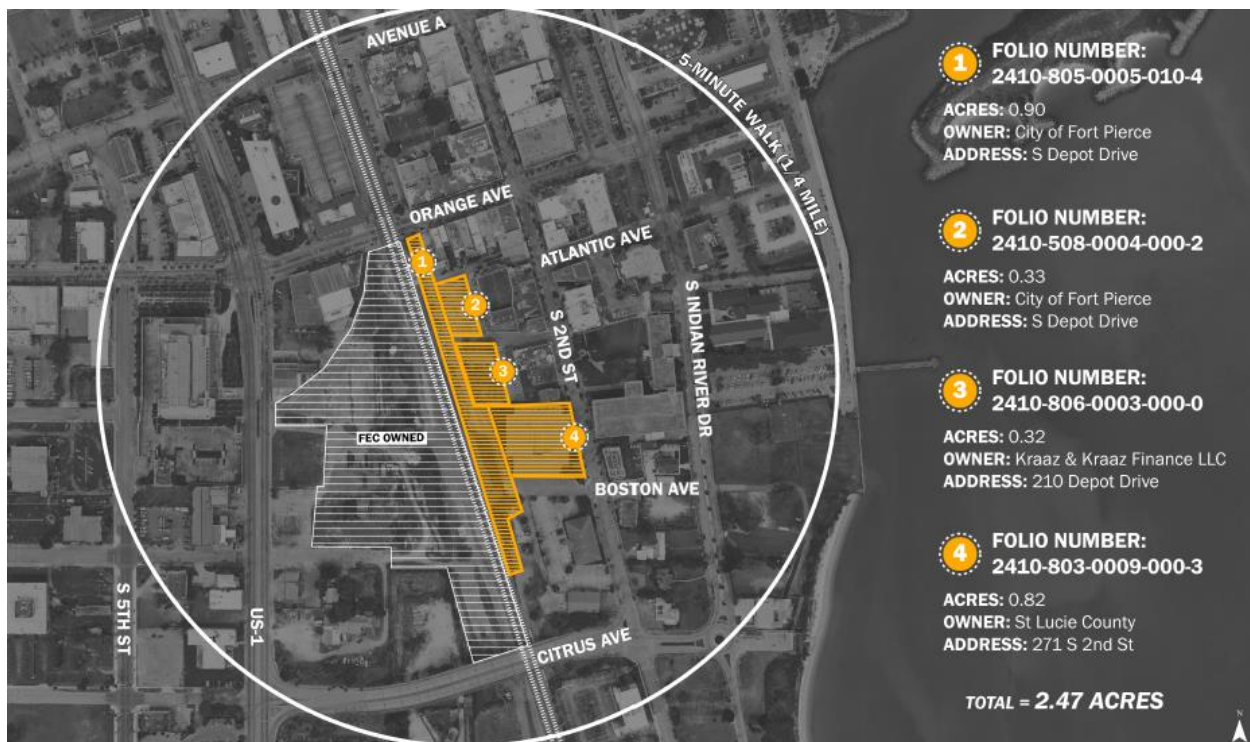

Figure 23: Parcel Layout and Ownership

St. Lucie County owns the 4th parcel which includes a public parking garage, which is proposed to be expanded and made available to Brightline patrons. Evidence of this commitment is provided through the St. Lucie County's Board of County Commission letter attached to this proposal (**Appendix B**). Although owned by the County, the City is committing to be responsible for any costs associated with making the 200 spaces in the garage or on adjacent surface parking available on an on-going basis.

Zoning

The Depot Drive Site is within the Central Business District of the City, which has Industrial and Commercial zoning. In December 2023, the City submitted a proposal to Brightline for a new train station. The proposed station, located at this same location, required revising the zoning code to allow the construction of Railway Passenger Stations and facilities in all commercial and industrial zoning districts.



The Planning Board approved the proposed changes, which remove setback, lot size, and landscape buffer requirements for Railway Passenger Stations. Code amendments were being revised to allow these changes which would additionally raise threshold limits for administrative approval of site plans for buildings with less than 10,000 square feet of floor space area. **Figure 24** shows the site on the City Zoning Map.

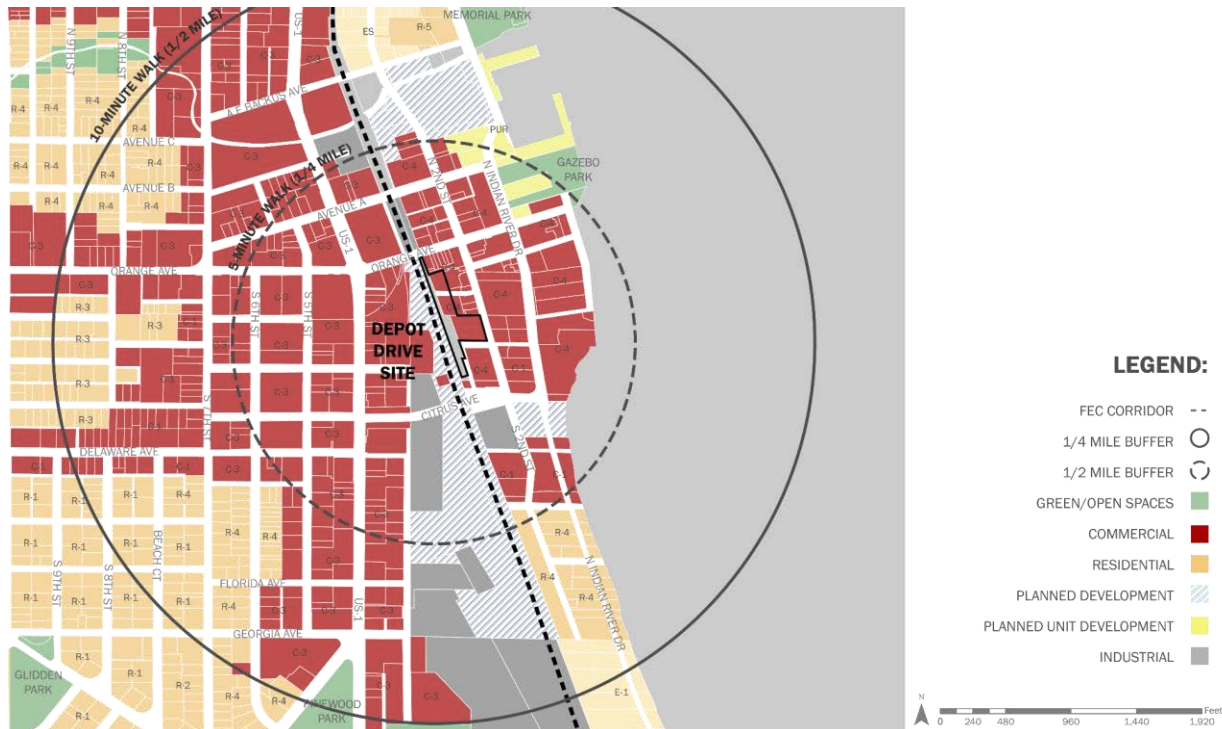

Figure 24: Site Location and Zoning

Station Layout

A station layout was prepared for the Depot Drive Site, but it must be noted that the site design and architectural renderings for a train station are very similar no matter where they are located. The renderings and concepts developed for the station are, for the most part, transferable to any site. The station layout is designed in a linear fashion along the east side of FEC Right-of-Way to accommodate a passenger platform and station. Note that a new rail side track is necessary to serve the station and not obstruct mainline rail activity. Figure 25 shows the station and platform layout with a new side track.



Figure 25: Station, Platform and Rail layout

Figure 26 provides a floor plan of the station and a larger, detailed image is included in **Appendix D**. The main entry to the station is located at the south end of the building where passengers will enter a lobby for train ticketing before moving north through the security gates into a baggage check area. Once passenger baggage has been screened and checked in the security area, passengers can move on to either the standard lounge or the premium lounge depending on the ticket purchased. Located in between these two lounges are public restrooms, an electrical room, and an area with table seating with laptop, tablet, phone charging, and power stations. This seating area could also accommodate vending machines.

Located at the north end of the station is the back-of-house area for staff and storage that would include an office, breakroom, storage, fire control room, and staff restrooms. There is an enclosed outdoor service yard located just north of the Back-of-House area for staff entry, loading, trash/recycling, standpipes, and the generator for the building. The building HVAC equipment will be located in a recess in the roof to shield the equipment from public view.

In all, the station building will consist of an elevated entry plaza of 1,000 SF (30' x 33'), a 6,400 SF of air conditioned space (214' x 30') and a 1,300 SF open-air service yard (60' x 32') for a total building size of 8,700 SF.

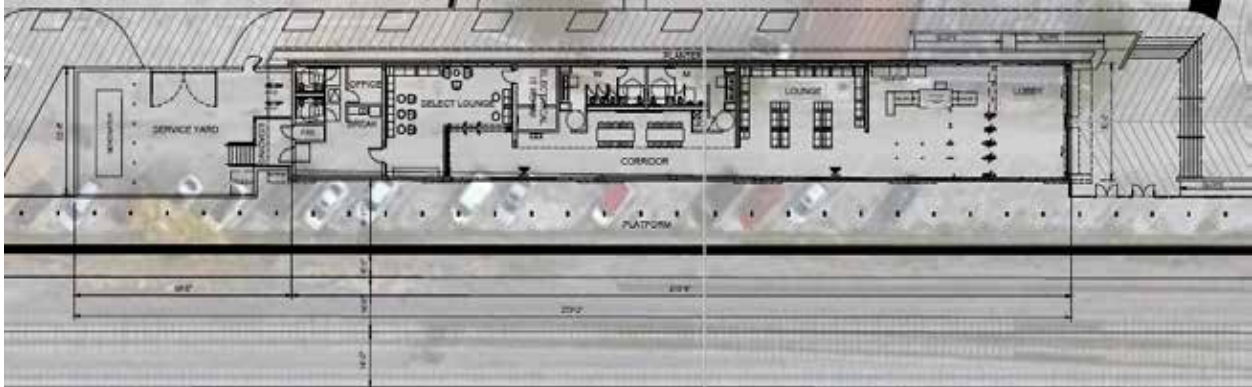

Figure 26: Station Floor Plan

Site Access

The site circulation has been designed as a mobility hub facilitating seamless integration with all modes of ground transportation. The main station entrance, **Figure 27**, will be designed in a pedestrian-friendly environment designed for very slow traffic, with a pick-up and drop-off traffic circle for rideshare and ART bus, Fort Pierce Tram shelter and a bike share rack located directly at the main entrance to the station. The site design also includes electric vehicle charging stations at parking stalls, Electric Vehicle (EV) bike-share racks, and EV scooter stations near the main entrance of the station as shown in **Figure 28**.



Figure 27: Pedestrian Friendly Station Main Access with Transit and Bike Share



Figure 28: EV Parking Spaces in Close Proximity to Station Main Entrance

The site will also have excellent pedestrian and bicycle access within the station area and access to the downtown area and be connected to the proposed Paseo Green Promenade that will connect from Orange Avenue to the proposed Culinary School and King's Landing Development. **Figure 29** shows a Paseo that connects to Orange Avenue that will also serve as a station service road for deliveries and maintenance.

Parking

The Brightline Station RFP identified a need to accommodate 200 parking spaces. The Depot Drive Site design exceeded that requirement with a total of 210 parking spaces on-site which could be dedicated for passengers, employees and rail operator shared-use vehicles. The plan, as depicted below, includes a convenient and simple access and circulation plan with parking located just steps away from the station. **Figure 30** shows the proposed on-site parking.

Design plans for a vertical expansion of the St. Lucie County Parking garage have been initiated, with 124 additional spaces. The expansion will be done through an interlocal agreement between the City and St. Lucie County, and it is anticipated that the responsibility will be outlined in the Development Agreement as an obligation of the City.



Figure 29: North End of Station Paseo Connection to Orange Avenue



Figure 30: Proposed Parking

The City has been proactive about planning for parking in the Downtown area and almost any site selected would have readily available parking in structured facilities or utilizing on-street parking to support curbside management and parking for a passenger rail station/mobility hub. **Figure 31** is a graphic taken from the City’s Downtown parking studies showing an inventory of 1,658 parking spaces including 1,208 off-street spaces and 450 on-street spaces.

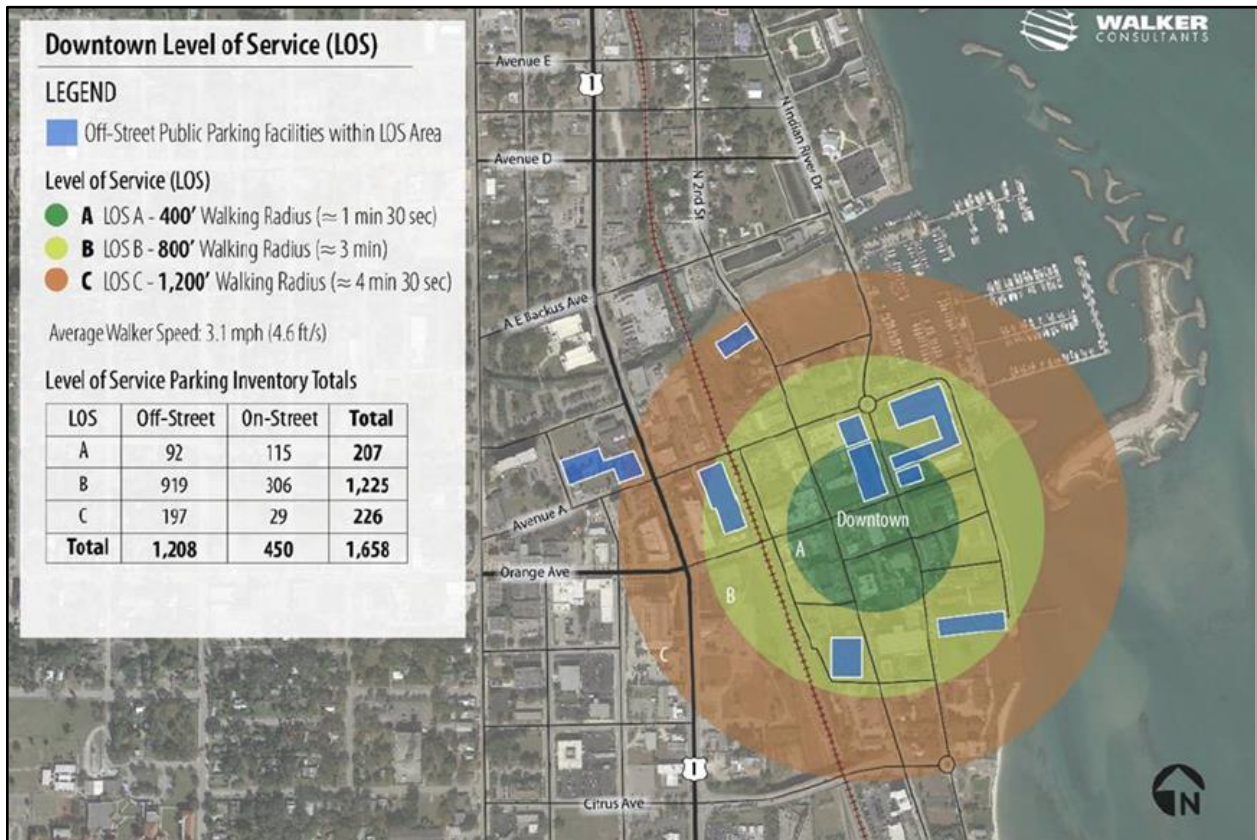

Figure 31: Downtown Parking Inventory



Chapter 5. Partners

The effort of bringing a new passenger rail station to Downtown Fort Pierce, taken by the TPO and the City of Fort Pierce, has received enormous support from different Regional Partners, local County and Municipal Agencies, and various private organizations representing multiple stakeholders and interests. These potential partners provided the City with numerous Letters of Support and Commitment in December 2023 for the potential construction of a Brightline Station in downtown Fort Pierce; copies of these letters is included in **Appendix B**. and summarized as follows:

- The St. Lucie County Board of County Commissioners supports the proposal. It suggests the inclusion of a county-owned parking garage to enhance functionality, highlighting benefits such as identifying a \$250,000 tourist tax-funded ridership commitment over three years, emphasizing St. Lucie County's attractions, tourism potential, and exceptional location within the Treasure Coast.
- The City of Port St. Lucie expressed excitement about partnering with Fort Pierce to bring a passenger rail station to Downtown Fort Pierce, emphasizing economic benefits and convenience for residents and businesses.
- Two different resolutions provide significant support for the development of a rail station in Downtown Fort Pierce:

RESOLUTION 23-R133: Provides Support from the City of Port St. Lucie: With over 240,000 residents, the City of Port St. Lucie expresses its support for locating a Brightline passenger rail station in Downtown Fort Pierce. Intercity passenger rail service is recognized as a major economic benefit for residents and businesses, indicating the potential for job creation and economic development. The resolution acknowledges Downtown Fort Pierce as an ideal location for the station, a sentiment supported by the City since October 2018.

RESOLUTION NO. 23-05: The Board of the St. Lucie Transportation Planning Organization reaffirms its support for locating a passenger rail station in Downtown Fort Pierce. Representing over 370,000 residents, the Board identifies passenger rail service as a need in its long-range transportation plans, emphasizing the importance of rail infrastructure. A Station in Downtown Fort Pierce is seen as beneficial for mobility, job creation, economic development, and tourism. The TPO has provided the funds to the City of Fort Pierce Passenger Rail Station planning.

Overall, both resolutions underline the strong support for developing a rail station in Downtown Fort Pierce, highlighting the economic, transportation, and community benefits associated with the project.

- The property owner located at Depot Drive provided a consent to negotiate the property with the city to facilitate the construction of the planned station and associated improvements,



emphasizing the potential for economic transformation and willingness to contribute to the project.

- Indian River State College expresses excitement about the prospect of a rail passenger station on the Treasure Coast and commits to securing financial investment for student passes, highlighting the benefits of increased transportation access.
- The New York Mets, who train during the Spring in Port St. Lucie, and Derecktor Shipyards express enthusiastic support for the proposed station in Fort Pierce, emphasizing economic growth, improved connectivity, and enhanced accessibility for visitors and employees.
- The Economic Development Council of St. Lucie County supports the proposal, highlighting economic growth, job creation, reduced traffic congestion, and enhanced transportation infrastructure. Main Street Fort Pierce and Lincoln Park Main Street express enthusiastic support for the proposal, highlighting the economic growth, vibrant atmosphere, and cultural enrichment it would bring to Downtown Fort Pierce and the wider community.
- The Fort Pierce Redevelopment Agency and St Lucie Chamber of Commerce emphasized their support for the train station and included how the city has several capital improvement projects already planned that will seamlessly integrate with the station, such as the restoration of historical buildings, creating pedestrian networks, and the expansion of green spaces, transforming the downtown area. These integrated efforts will secure Fort Pierce as a central hub for transportation, commerce, and culture.

The project gathered support from regional partners, including the Cities of Sebastian, Fellsmere, Vero Beach, and Okeechobee, as well as from Indian River County MPO, and Okeechobee County Commissioners. All expressed support for the proposal, highlighting its economic benefits, improved transportation, and enhanced connectivity for residents and visitors.

Overall, the support from these potential partners emphasizes the significant benefits and opportunities associated with constructing a passenger rail station in Downtown Fort Pierce.





St. Lucie Transportation Planning Organization



Fort Pierce Passenger Rail Station/
Mobility Hub & Station Concept Plan



Indian River County MPO

LNPK MAIN STREET LINCOLN PARK

MAIN STREET FORT PIERCE

CITY OF VERO BEACH FLORIDA

CITY OF OKECHOBEE FLORIDA

CITY OF FT. PIERCE FLORIDA

CITY OF SEBASTIAN HOME OF PELICAN ISLAND

FPRA FORT PIERCE REDEVELOPMENT AGENCY



Appendices

[Appendix A - Parking, Traffic and Crash Reports](#)

[Appendix B - Support Letters](#)

[Appendix C - City of Fort Pierce Brightline Proposal](#)

[Appendix D - Station Floor Plan](#)



AGENDA ITEM SUMMARY

Board/Committee:	Technical Advisory Committee (TAC)
Meeting Date:	May 21, 2024
Item Number:	6d
Item Title:	Transit Development Plan (TDP) Major Update
Item Origination:	Unified Planning Work Program (UPWP)
UPWP Reference:	Task 3.2 – Transit Planning
Requested Action:	Recommend endorsement of the draft TDP Major Update, recommend endorsement with conditions, or do not recommend endorsement.
Staff Recommendation:	Because the TDP Major Update supports the operation and growth of St. Lucie County's transit system to meet the identified transit needs over the next 10 years, it is recommended that the TDP Major Update be recommended for acceptance by the TPO Board.

Attachments

- Staff Report
- Draft TDP Major Update



Coco Vista Centre
 466 SW Port St. Lucie Blvd, Suite 111
 Port St. Lucie, Florida 34953
 772-462-1593 www.stlucietpo.org

MEMORANDUM

TO: Technical Advisory Committee (TAC)

FROM: Peter Buchwald
 Executive Director

Marceia Lathou
 Transit/ACES Program Manager

DATE: May 15, 2024

SUBJECT: Transit Development Plan (TDP) Major Update

BACKGROUND

A Transit Development Plan (TDP) is required by the Florida Department of Transportation (FDOT) for the receipt of funding through the Public Transit Block Grant Program. A TDP is the public transportation provider's planning, development, and operational guidance document and is based on a 10-year planning horizon. A Major Update is required every five years. Annual updates in the form of progress reports on the 10-Year Implementation Program of the TDP are also required.

In St. Lucie County, the Board of County Commissioners (BOCC) contracts with MV Transportation for public transportation services. A TDP Major Update is adopted by the BOCC after endorsement by the TPO Board.

Task 3.2 of the St. Lucie TPO FY 2022/23 - 2023/24 Unified Planning Work Program (UPWP) includes activities related to the provision of technical and planning assistance to the BOCC to maintain the BOCC's eligibility for the continued receipt of Federal and state transit funds. These activities include supporting the TDP Major Update and Annual Progress Reports.

ANALYSIS

As the intent of the TDP Major Update is to reimagine the current transit system in the TPO area, the Update is branded *Reimagine Transit*. The County

Transit Department and consultants have conducted extensive public outreach, trend and peer analyses, and data collections efforts over the past year.

These efforts identified and prioritized the transit needs for the TPO area and after the evaluation of the projected revenues, the following transit services and projects are proposed to be implemented over the next 10 years:

Transit Improvements	Implementation Year (FY)	Annual Operating Cost (2025\$)	Total Capital Cost (2025\$)	Potential Revenue Source
Central Fort Pierce ART On Demand	2025	\$368,269	\$224,691	Local/FDOT Serv. Dev.
Port St. Lucie Express	2025	\$1,100,000	N/A	FDOT Corridor Dev./PalmTran
30-minute Frequency on Route 1	2025	\$702,979	N/A	Local
Streamline Route 7	2025	\$0	N/A	Local
Extended Route 8	2025	\$182,351	N/A	Local
Establish Vanpool	2025	\$100,000	N/A	Local
South St. Lucie ART On Demand	2029	\$694,620	\$224,691	Local/FDOT Serv. Dev.
Add Sun. Service on Routes 1, 2, 3, and 4	2030	\$132,538	N/A	Local
Indian River Estates ART On Demand	2031	\$694,620	\$224,691	Local/FDOT Serv. Dev.
Add Saturday Service on Route 8	2031	\$79,523	N/A	Local
30-minute Frequency on Route 3	2033	\$351,450	\$600,000	Local
North St. Lucie ART On Demand	2033	\$694,620	\$224,691	Local/FDOT Serv. Dev.
Extend Weekday Service Span to 10 PM	2034	\$343,918		Local
Dual Enrollment Shuttle	2034	\$343,918	\$1,200,000	Local
Downtown/Passenger Rail Station/Beach Shuttle	2034	\$414,605	\$600,000	Local
Bus Stop/Shelter Improvements	2025	N/A	\$100,000	FTA
Port St. Lucie Intermodal	2025-2027	N/A	\$5,000,000	Local/FTA
Operations and Maintenance Facility	2025-2029	N/A	\$30,000,000	Local/FTA
Fare Policy/Structure Evaluation Study	2026	N/A	\$300,000	Local
Expand Transit Marketing/ Education Program	2026	N/A	\$100,000	Local
TSP	2026-2033	N/A	\$25,000	Local/FTA
Queue Jumps	2026-2033	N/A	\$150,000	Local/FTA

Transit Improvements	Implementation Year (FY)	Annual Operating Cost (2025\$)	Total Capital Cost (2025\$)	Potential Revenue Source
Wi-Fi on Buses	2027-2034	\$25,000	\$100,000	Local

Additional details will be presented on the year-long efforts and the corresponding results including identification of the transit needs and the proposed transit services and projects to address those needs over the next 10 years.

RECOMMENDATION

Because the TDP Major Update supports the operation and growth of St. Lucie County’s transit system to meet the identified transit needs over the next 10 years, it is recommended that the TDP Major Update be recommended for acceptance by the TPO Board.



Transit Development Plan

May 2024

Draft Report



Table of Contents

Section 1. Introduction.....	1-1
Objectives of This Plan	1-1
TDP Requirements	1-1
<i>Reimagine Transit</i> TDP Process	1-2
Organization of This TDP	1-5
Section 2. Baseline Conditions.....	2-1
Study Area	2-1
Population	2-1
Employment.....	2-5
Households.....	2-8
Socio-Demographic Characteristics and Trends	2-11
Travel Behavior and Commuting Trends	2-27
Transportation Disadvantaged (TD) Population	2-30
Major Trip Generators	2-30
Tourism.....	2-37
Roadway and Traffic Conditions	2-38
Current and Future Land Uses.....	2-38
Section 3. Existing Transit Services.....	3-1
Transit Services Profile	3-1
Transit Service Characteristics and Trends.....	3-5
Existing Transit Facilities	3-8
Future Administration and Maintenance Facility	3-10
Vehicle Inventory.....	3-10
Other Transportation Providers	3-11
Farebox Recovery.....	3-13
Peer and Trend Analysis.....	3-13
Section 4. Public Involvement Summary.....	4-1
Public Involvement Techniques	4-1
Summary of <i>Reimagine Transit</i> Public Involvement Activities.....	4-1
Stakeholder Interviews	4-3
Bus Operator Interviews and Survey	4-8
Discussion Group Workshops	4-9
Phase I Outreach	4-14
Phase II Outreach	4-25
Transit Priorities Survey.....	4-27
Web and Social Media Outreach.....	4-28
Section 5. Situation Appraisal.....	5-1
Review of Plans and Studies.....	5-1

Situation Appraisal.....	5-6
Section 6. Goals and Objectives.....	6-1
Section 7. Transit Demand and Accessibility Assessment.....	7-1
Transit Market Assessment.....	7-1
Existing Transit Accessibility Analysis.....	7-9
Ridership Demand Assessment.....	7-13
Ridership Forecast.....	7-16
Section 8. Transit Needs Development.....	8-1
Development of Transit Needs.....	8-1
10-Year Transit Needs.....	8-2
Evaluation of Transit Needs.....	8-12
Section 9. Reimagine Transit: 10-Year Plan.....	9-1
<i>Reimagine Transit</i>	9-1
10-Year TDP Financial Plan.....	9-8
10-Year TDP Implementation Plan.....	9-15
Section 10. Coordination and Implementation.....	10-1
Implementation/Coordination Action Items.....	10-1

List of Figures

Figure 1-1: Reimagine Transit TDP Process.....	1-3
Figure 2-1: Population Projection 2025-2050.....	2-1
Figure 2-2: Occupations 2021.....	2-5
Figure 2-3: Housing Tenure 2021.....	2-8
Figure 2-4: Percent of Older Adults (65+) 2025-2050.....	2-11
Figure 2-5: Household Income Distribution 2021.....	2-15
Figure 2-6: Age Distribution of Individuals with Disabilities 2021.....	2-17
Figure 2-7: Highest Educational Attainment.....	2-19
Figure 2-8: Race and Ethnicity 2021.....	2-21
Figure 2-9: LEP Household Language Breakdown 2021.....	2-23
Figure 2-10: Number of Vehicles Owned by Household 2021.....	2-25
Figure 2-11: Commute Modes 2021.....	2-28
Figure 2-12: Departure Time to Work 2021.....	2-29
Figure 2-13: Commute Time Transit vs Drove Alone.....	2-29
Figure 2-14: TD Trips by Purpose 2021.....	2-30
Figure 3-1: ART Ridership 2015-2024.....	3-5
Figure 3-2: ART Ridership Monthly FY 2022.....	3-6
Figure 3-3: ART Ridership per Hour by Route FY 2022.....	3-7

Figure 4-1: Have you or a member of your household used St. Lucie County’s public transportation service, Area Regional Transit (ART)? 4-16

Figure 4-2: How important is providing bus transit services in St. Lucie County? 4-17

Figure 4-3: Do you think there is a need for additional/improved transit services in St. Lucie County?.. 4-17

Figure 4-4: What would make transit services more appealing for you to use it or use it more? 4-18

Figure 4-5: If you use bus services, or decide to use them in the future, where would you use it to go?.. 4-18

Figure 4-6: What improvements should ART prioritize over the next 10 years? 4-19

Figure 4-7: Currently there is no cost to ride St. Lucie County’s fixed-route service, ART. Does this encourage you to use the service more? 4-19

Figure 4-8: If you are currently employed, how has your work commute changed since the pandemic? 4-20

Figure 4-9: How old are you? 4-22

Figure 4-10: Do you have access to a personal vehicle? 4-22

Figure 4-11: Gender 4-23

Figure 4-12: Race 4-23

Figure 4-13: Ethnicity 4-24

Figure 4-14: Household Income 4-24

Figure 4-15: Transit Priorities Survey Results 4-27

Figure 7-1: TOI Methodology 7-7

Figure 7-2: Components of the 90-Minute Bus Trip 7-10

Figure 8-1: ART Operations & Maintenance Facility Concept 8-8

Figure 8-2: High Ridership Bus Stop Concept 8-8

Figure 8-3: TSP with Queue Jump Lane Concept 8-9

Figure 9-1: Mode Share | Existing and Reimagine Transit 9-2

Figure 9-2: Proposed Port St. Lucie Intermodal Center 9-7

Figure 9-3: 10-Year Vehicle Replacement and Acquisition Cost Plan 9-10

Figure 9-4: Total Costs – Operating and Capital 9-13

Figure 9-5: Total Costs and Revenues 9-13

Figure 9-6: 10-Year Revenue Distribution 9-15

Figure 10-1: Route Performance Evaluation Levels E-2

List of Maps

Map 2-1: Study Area | St. Lucie County 2-2

Map 2-2: Population Density | 2025 2-3

Map 2-3: Population Density | 2034 2-4

Map 2-4: Employment Density | 2025 2-6

Map 2-5: Employment Density 2034	2-7
Map 2-6: Households Density 2025	2-9
Map 2-7: Households Density 2034	2-10
Map 2-8: Older Adults	2-12
Map 2-9: Younger Adults	2-14
Map 2-10: Poverty	2-16
Map 2-11: Households with Disabilities	2-18
Map 2-12: Educational Attainment	2-20
Map 2-13: Race and Ethnicity	2-22
Map 2-14: Limited English Proficiency	2-24
Map 2-15: Zero Vehicle Households	2-26
Map 2-17: Shopping, State Parks, Event Centers	2-33
Map 2-18: Higher Education Centers	2-36
Map 2-19: Roadway and Traffic Conditions	2-39
Map 2-20: Future Land Use St. Lucie County	2-40
Map 2-21: Future Land Use Fort Pierce	2-41
Map 2-22: Future Land Use Port St. Lucie	2-42
Map 3-1: ART Existing Services	3-3
Map 4-1: Home ZIP Codes	4-21
Map 4-2: Work ZIP Codes	4-21
Map 7-1: DTA 2025	7-4
Map 7-2: DTA 2034	7-5
Map 7-3: TOI 2023	7-8
Map 7-4: Fort Pierce Intermodal Center Accessibility	7-11
Map 7-5: Port St. Lucie Intermodal Center Accessibility	7-12
Map 8-1: Reimagine Transit TDP 10-Year Needs	8-3
Map 9-1: 2034 Reimagine Transit Network	9-5

List of Tables

Table 1-1: TDP Checklist	1-4
Table 2-1: Commute Patterns Inflow and Outflow	2-27
Table 2-2: Top 10 Major Employers	2-34
Table 3-1: Fixed-Route Service Characteristics 2023	3-2
Table 3-2: Vehicle Inventory 2023	3-11
Table 3-3: Fixed-Route Trend Analysis 2018-2022	3-14
Table 3-4: Demand-Response Trend Analysis 2018-2022	3-16
Table 3-5: Fixed-Route Peers	3-18
Table 3-6: Fixed-Route Peer Analysis	3-19

Table 3-7: Demand-Response Peers.....	3-20
Table 3-8: Demand-Response Peer Analysis.....	3-20
Table 4-1: TDP Public Involvement Summary.....	4-2
Table 4-2: Stakeholder Information	4-4
Table 5-1: Local Plans	5-2
Table 5-2: Regional Plans.....	5-4
Table 5-3: State Plans.....	5-5
Table 7-1: DTA Density Thresholds.....	7-2
Table 7-2: Ridership Projections Status Quo and TDP Scenarios.....	7-16
Table 8-1: ART 10-Year Needs Service Characteristics.....	8-7
Table 8-2: 10-Year TDP Service Needs Evaluation Factors and Weights.....	8-13
Table 8-3: 10- Year Needs Evaluation – Scoring Thresholds.....	8-14
Table 8-4: 10- Year Service Improvements Evaluation Results	8-15
Table 9-1: Recommended ART 10-Year Network Characteristics.....	9-6
Table 9-2: 10-Year Financial Plan.....	9-14
Table 9-3: Reimagine Transit TDP Implementation Plan and Unfunded Needs Service.....	9-16
Table 9-4: Reimagine Transit TDP Implementation Plan and Unfunded Needs Capital.....	9-17

Section 1. Introduction

This effort was initiated by the St. Lucie Transportation Planning Organization (TPO) in collaboration with Area Regional Transit (ART) to prepare a Major Update of the 10-Year Transit Development Plan (TDP), also dubbed “*Reimagine Transit TDP.*”

This TDP represents the reimagined St. Lucie County’s vision for transit from 2024 to 2033, functioning as the strategic guide for public transportation for the community. This major TDP update also allows the transit and planning agencies in St. Lucie County to outline actions to be taken in the following year and set transit goals for subsequent years. As a strategic plan, the TDP will also identify needs in an unconstrained fashion and for which currently there is no funding. As a development plan for local transit services, the plan will be consistent with community goals, reflect the priorities that leadership have established, and integrate the various community characteristics and development patterns that influences decisions and growth within St. Lucie County and its municipalities.

Preparing and submitting a TDP major update that complies with Florida Administrative Code (F.A.C.) Rule 14-73.001 (commonly called the TDP Rule) every five years is also required by the Florida Department of Transportation (FDOT) as a prerequisite to the receipt of State Block Grant funds. According to F.A.C. Rule 14-73.001 – Public Transportation, “The TDP shall be the applicant’s planning, development and operational guidance document to be used in developing the Transportation Improvement Program and the Department’s Five-year Work Program.”

A major TDP update also allows transit agencies to outline actions to be taken in the following year and set goals for subsequent years. The most recent 10-year TDP major update for ART was adopted in July 2019 for Fiscal Years (FY) 2020–2029. This current major update for FY 2025–2034 is due by September 1, 2024.

Objectives of This Plan

The main purpose of this effort is to update the TDP for ART’s transit services, as currently required by State law for agencies receiving State Block Grant funding for transit. This TDP also is a 10-year plan for transit and mobility needs, cost and revenue projections, and community transit goals, objectives, and policies. This Major Update supports a unified vision with realistic goals and recommendations that stakeholders, citizens, and decisionmakers can support and promote.

TDP Requirements

FDOT requires that recipients of state Public Transit Block Grant funds prepare a major update of their TDP every five years to ensure that the provision of ART’s public transportation system in St. Lucie County is consistent with the mobility needs of local communities. Current TDP requirements were formally adopted by FDOT on February 20, 2007. Major requirements of the rule include the following:

- Major updates must be completed every 5 years, covering a 10-year planning horizon.

- A Public Involvement Plan must be developed and approved by FDOT or consistent with the approved Metropolitan Planning Organization (MPO) Public Involvement Plan.
- FDOT, the Regional Workforce Development Board, and the MPO must be advised of all public meetings at which the TDP is presented and discussed, and these entities must be given the opportunity to review and comment on the TDP during the development of the mission, goals, objectives, alternatives, and 10-year implementation program.
- Estimation of the community’s demand for transit service (10-year annual projections) must use the planning tools provided by FDOT or a demand estimation technique approved by FDOT.

Reimagine Transit TDP Process

The process to develop the *Reimagine Transit* TDP is consistent with FDOT’s *Guidance for Preparing & Reviewing Transit Development Plans, Ver III (2022)* known as the “TDP Handbook.” As shown in Figure 1-1, it includes a series of discrete and interrelated tasks, including the baseline conditions assessment tasks summarized in this technical memorandum. All tasks combine to contribute to the full picture of the current operating environment and existing/future transit needs in St. Lucie County and its immediate region.

TDP Checklist

This TDP Update meets the requirements for a TDP major update in accordance with Rule Chapter 14-73, F.A.C. Table 1-1 is a list of TDP requirements from Rule 14-73.001 and indicates whether or not the item was accomplished as part of the *Reimagine Transit* TDP and its location within this 10-year plan.

Figure 1-1: Reimagine Transit TDP Process

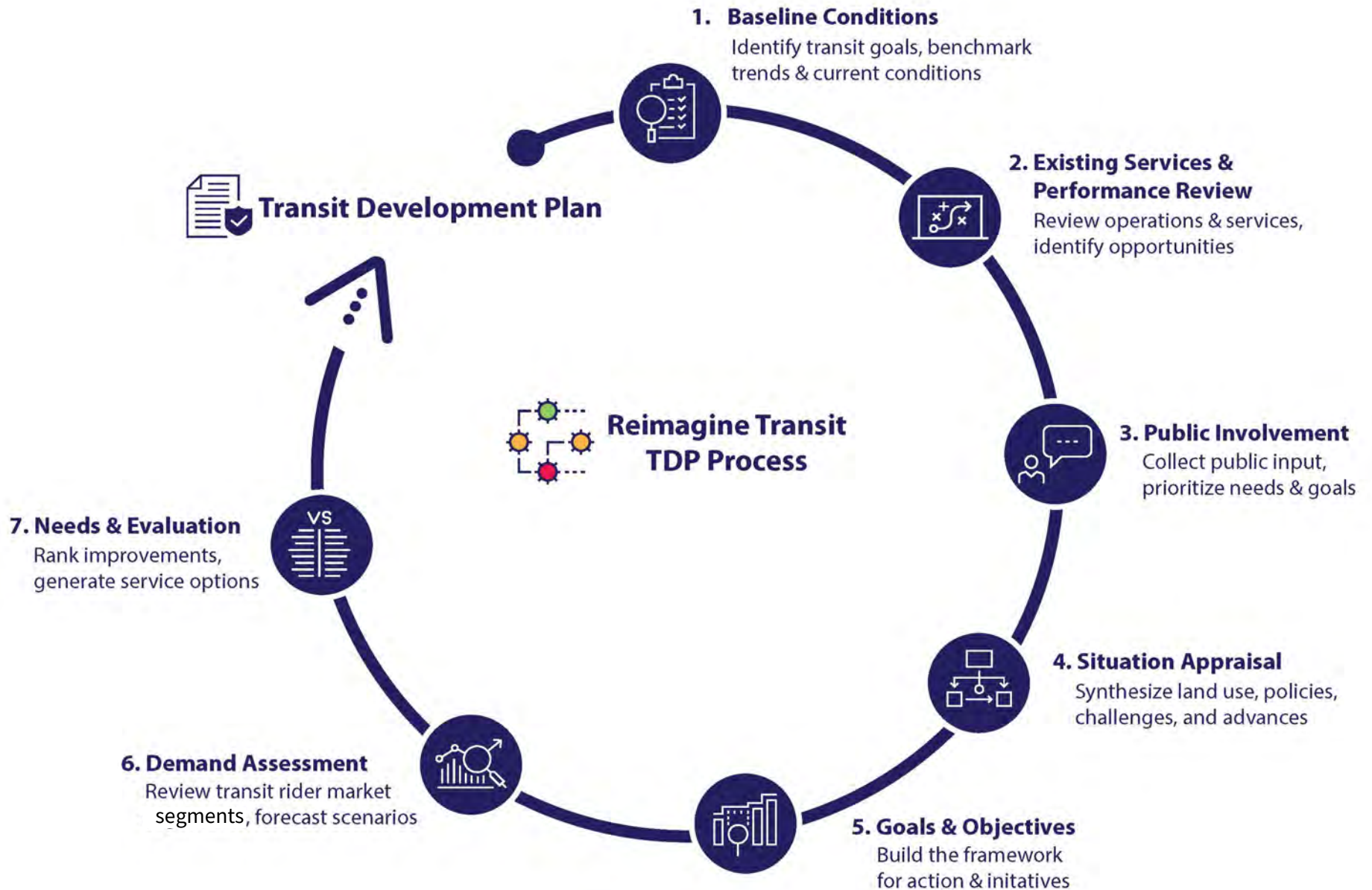

Table 1-1: TDP Checklist

Public Involvement Process		TDP Section
√	FDOT-approved TDP Public Involvement Plan (PIP)	4 & Appendix D
√	Opportunities for public involvement outlined in PIP	4 & Appendix D
√	Solicitation of comments from RWB	4
√	Notification to FDOT, RWB, and TPO about public meetings	4 & Appendix D
√	Provision of review opportunities to FDOT, RWB, and TPO	4
Situation Appraisal		
√	Plans and policy review	5
√	Socioeconomic trends	5
√	Land use	5
√	Organizational issues	5
√	Technology/innovation	5
√	Transit-friendly land use and urban design efforts	5
√	10-Year transit ridership projections	7
√	Farebox Recovery report	3 & Appendix B
Mission and Goals		
√	Mission and vision	6
√	Goals and objectives	6
Alternatives Development & Evaluation		
√	Documentation of development of transit alternatives	8
√	Documentation of evaluation of transit alternatives	8
Implementation Program		
√	10-year program of improvement strategies and policies	9
√	Maps indicating areas to be served and types and levels of service	9
√	10-year financial plan showing funding sources and expenditures of funds	9
√	Documentation of monitoring program to track performance	9 & Appendix E
√	Implementation plan with projects and/or services needed to meet the goals and objectives in the TDP	9
√	List of unfunded needs	9
Relationship to Other Plans		
√	Consistent with Florida Transportation Plan	5
√	Consistent with local government comprehensive plan	5
√	Consistent with regional transportation goals and objectives	5
Submission		
	Adopted by St. Lucie County BOCC	
	Submitted to FDOT	

Organization of This TDP

This report is organized into 10 major sections, including this **Introduction**.

Section 2 summarizes the **Baseline Conditions** for the defined study area. This includes a review of the physical description of the study area and a population profile including demographic and socioeconomic characteristics and trends, including employment, income distribution, race, educational attainment, and poverty levels. Additionally, travel behavior and commuting trends are reviewed, including transportation ownership, modes of commuting, regional commute flows, and journey-to-work characteristics. Land use trends, transportation disadvantaged, major developments, major transit trip generators and attractors, Annual Average Daily Traffic (AADT), major activity centers, and tourism, also are explored.

Section 3 summarizes the **Existing Transit Service Review** for ART. An analysis of ART data and information is presented to help understand demand for and supply of transit services. The trend and peer section examines historical data on service metrics for fixed-route service to better understand system-level performance over time and in comparison to other similar systems, and a performance trend analysis provides a detailed examination over time of operating data for ART’s fixed-route and demand response services. A peer agency review provides an opportunity for ART to compare its system-wide effectiveness and efficiency indicators with selected peer transit systems to help to determine how well transit service is performing locally compared to similar transit agencies elsewhere.

Section 4 presents the **Public Involvement Summary**, including a summary review of the outreach efforts completed for the TDP and the associated findings. TDP outreach efforts were conducted in two phases and include stakeholder interviews, public input surveys, discussion groups workshops, general public workshops, and presentations as well as use of online platforms and tools.

Section 5 provides the **Situation Appraisal**, which reviews the current planning and policy environment in the county to better understand transit needs. It begins with a plans and policy review, including an overview of what each plan or policy aims to address and highlights key implications for transit within St. Lucie County. Strengths and weaknesses of the system and potential threats to the provision of service in the county are identified, as are key opportunities for addressing the threats. In addition, insights are presented based on review of socioeconomic trends, travel behavior and trends, public involvement, land use assessments, organizational attributes and funding issues, and technologies impacting the provision of transit service. While the community goals, growth factors, and development patterns will be integrated throughout the plan sections, the section that will govern and guide how the major influencing factors for successful growth and guiding principles will be reflected in the Situation Appraisal. It will reflect the community profile and patterns of the community feeding into the plan and define the goals and implementation strategies to move ahead and meet the needs of St. Lucie County.

Section 6 provides draft **Goals and Objectives** to serve as a policy guide for implementation of the TDP. Proposed revisions to the existing goals and objectives are presented to ensure consistency with the goals of the local community with respect to transportation.

Section 7 presents the **Transit Demand Assessment** summarizing the various demand and mobility needs assessments conducted as part of the TDP. Included is a market assessment that provides an examination of potential service gaps and latent demand using GIS-based analyses. A transit accessibility assessment also was conducted to provide an understanding of the reach of existing services within a set time window. Additionally, forecasted ridership estimates using the Transit Boardings Estimation and Simulation Tool (TBEST) are summarized.

Section 8 discusses **Transit Needs Development**. Improvements were developed based on four factors, including community needs and vision, situation appraisal, goals and objectives, and transit demand analysis. The 10-year needs are summarized based on service improvement type and supporting capital needs. This section also includes the transit needs evaluation used to assess the identified improvements for the 10-year TDP. These results were then used to develop the 10-year TDP financial and implementation plans.

Section 9 summarizes the **10-Year Transit Plan** developed for ART's transit service. The Plan shows the recommended service and capital/technology/policy improvements as well as the unfunded needs. It also includes a discussion of the revenue assumptions and capital and operating costs used. Thereafter, the 10-year phased implementation plan for the TDP is summarized. A set of service, capital/technology, and policy improvements are programmed for the 10-year period, and the improvements that may not be funded now but should be considered if additional funding becomes available are also listed.

Section 10 summarizes techniques and approaches to help facilitate **Plan Implementation and Coordination** after adoption of the TDP. This section identifies implementation strategies and ways to make use of the various relationships, tools, and outreach materials from the TDP process to continue to build support for the implementation of the 10-Year TDP.

Section 2. Baseline Conditions

This section reviews the study area in the context of St. Lucie County and seeks to gain an understanding of the conditions in which ART is operating and potential influencing factors. This information provides the foundation upon which to review or analyze trends and helps identify areas of opportunity for development of future modified, enhanced, and/or expanded transit services.

Study Area

St. Lucie County is located on the east coast of Florida and is bordered on the north by Indian River County; on the west by Okeechobee County; on the east by the Atlantic Ocean; and to the south by Martin County. The total land area of the county is 572 square miles with 21 miles of coastline. St. Lucie County’s incorporated areas include the City of Fort Pierce (county seat), City of Port St. Lucie, and St. Lucie Village. Six major roadways intersect St. Lucie County: I-95, Florida’s Turnpike, US 1, SR-A1A, SR-68 (Orange Ave), SR-70 (Okeechobee Road and Virginia Ave), and SR-709 (Glades Cut Off Road). Map 2-1 illustrates the study area for the *Reimagine Transit* TDP.

Population

Higher population density can be a key indicator of a healthy transit market. Areas with high population density often are associated with land uses that promote transit use and amenities that promote pedestrian and bicycle activity. St. Lucie County is expected to experience population growth over the next two decades, with population exceeding 400,000 residents by 2030, and more than 480,000 residents by 2050. However, it is expected that the annual population growth rate will slow down from 9% in 2030 to 4% in 2050. Areas with expected higher growth are concentrated west of I-95 in Port St. Lucie. Parts of Fort Pierce are also expected to see higher density growth (more than 1,000 persons per square mile).

Figure 2-1: Population Projection | 2025-2050

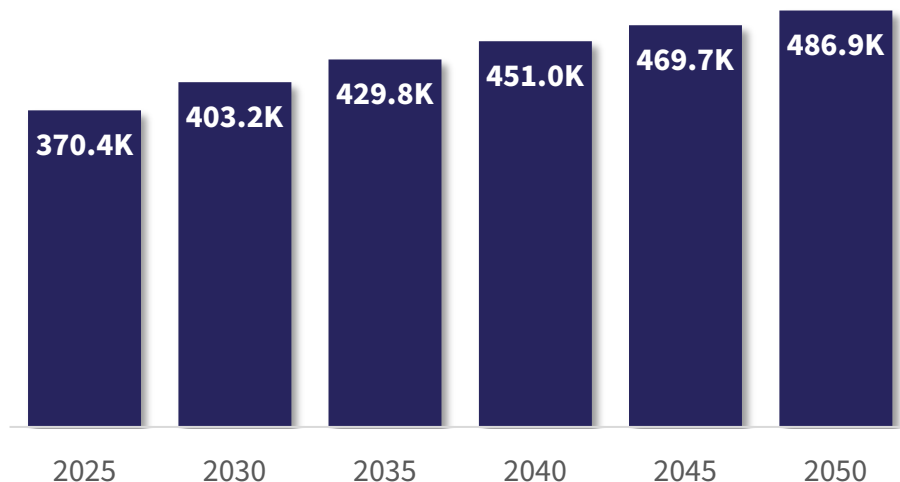

Source: University of Florida Bureau of Economic and Business Research (BEBR) Medium Projections

Map 2-1: Study Area / St. Lucie County

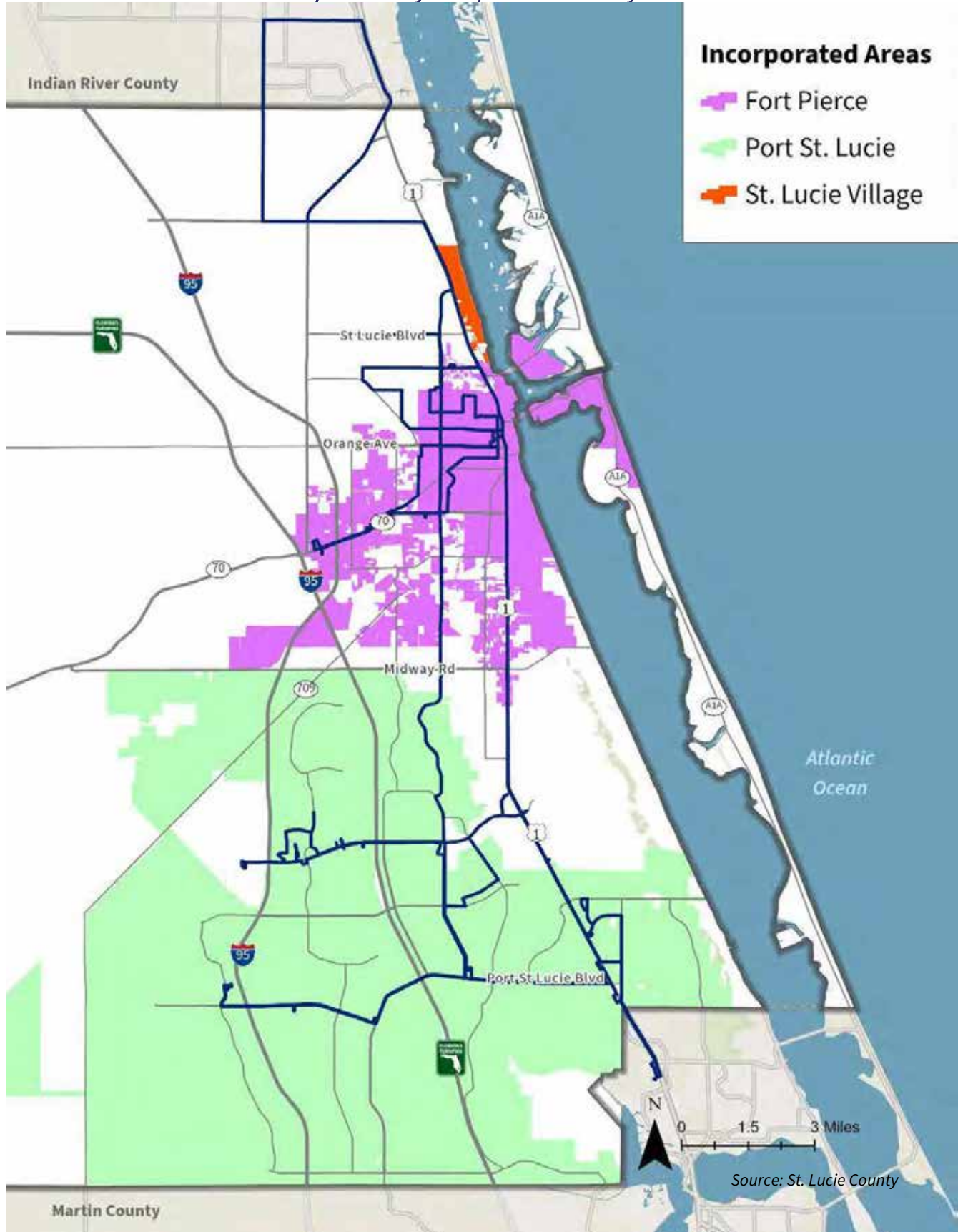

Map 2-2: Population Density | 2025

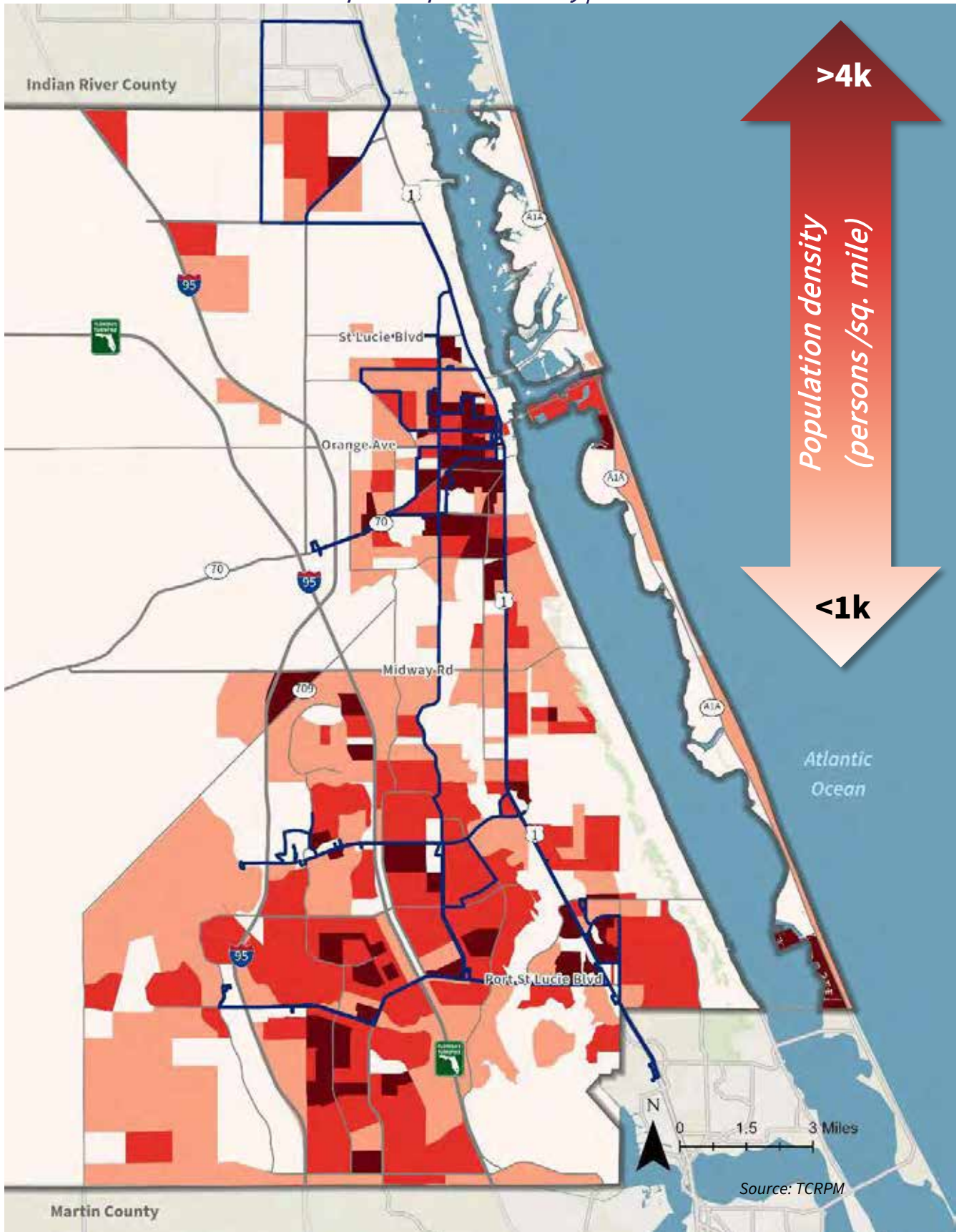

Map 2-3: Population Density | 2034

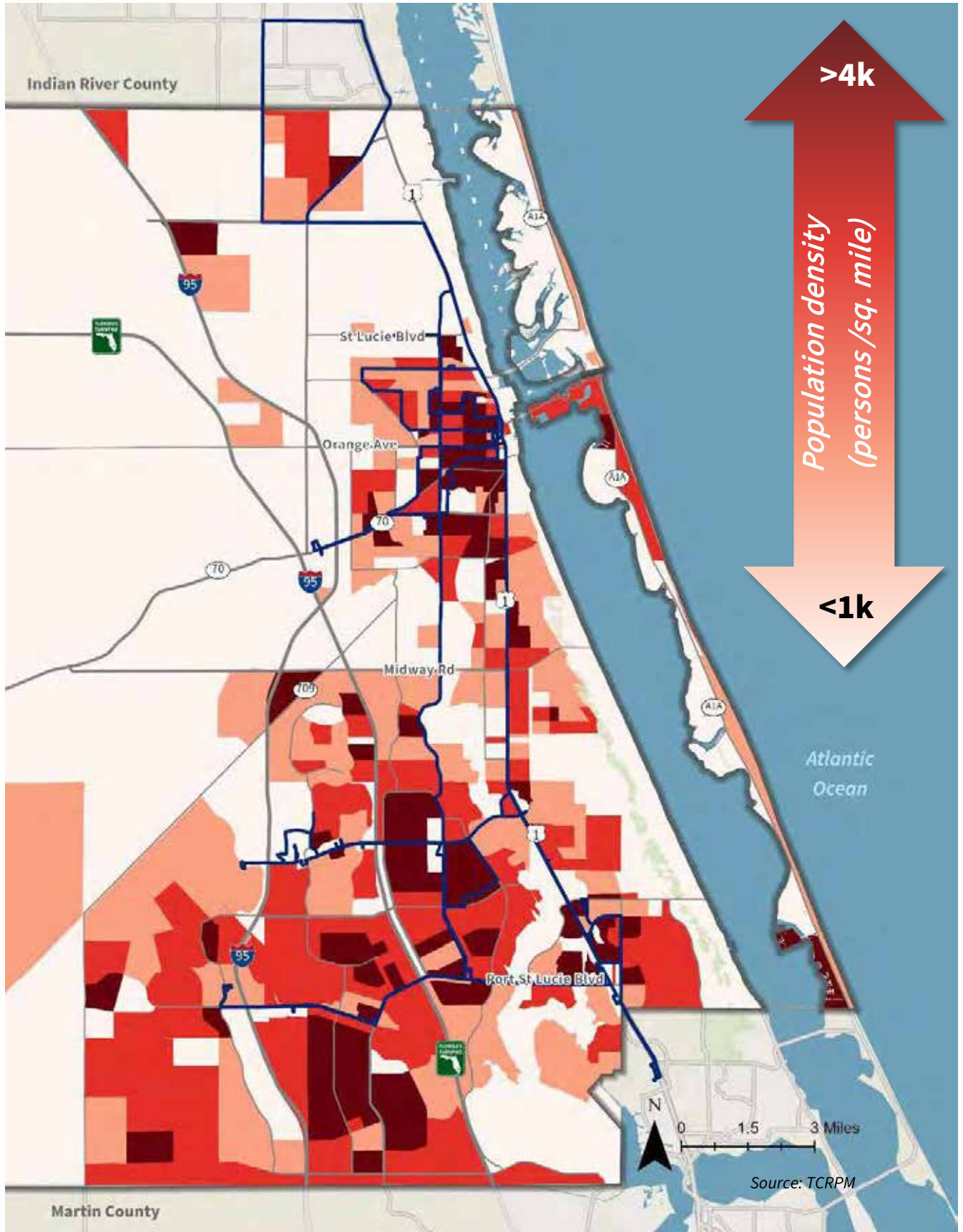

Employment

Employment density is another important factor to consider when analyzing a transit market. Areas of high employment density often include activity centers that cluster shopping centers, medical offices, and/or educational centers that attract transit trips. Urban centers like downtowns also tend to have higher employment densities and more limited parking, which also can increase transit demand.

Employment markets and transit service hours can also influence transit use, particularly by those that are transit dependent or work non-traditional work hours (e.g., third shift workers). Based on 2021 data, the largest employment sectors in St. Lucie County are education/health care/social assistance (22%), retail (14%), professional/management/ administrative (11%), and art/recreation/food services (11%), making up nearly 60% of employment in St. Lucie County.

Figure 2-2: Occupations | 2021



Source: ACS 5-Year Estimates (2017-2021)

Map 2-4: Employment Density | 2025

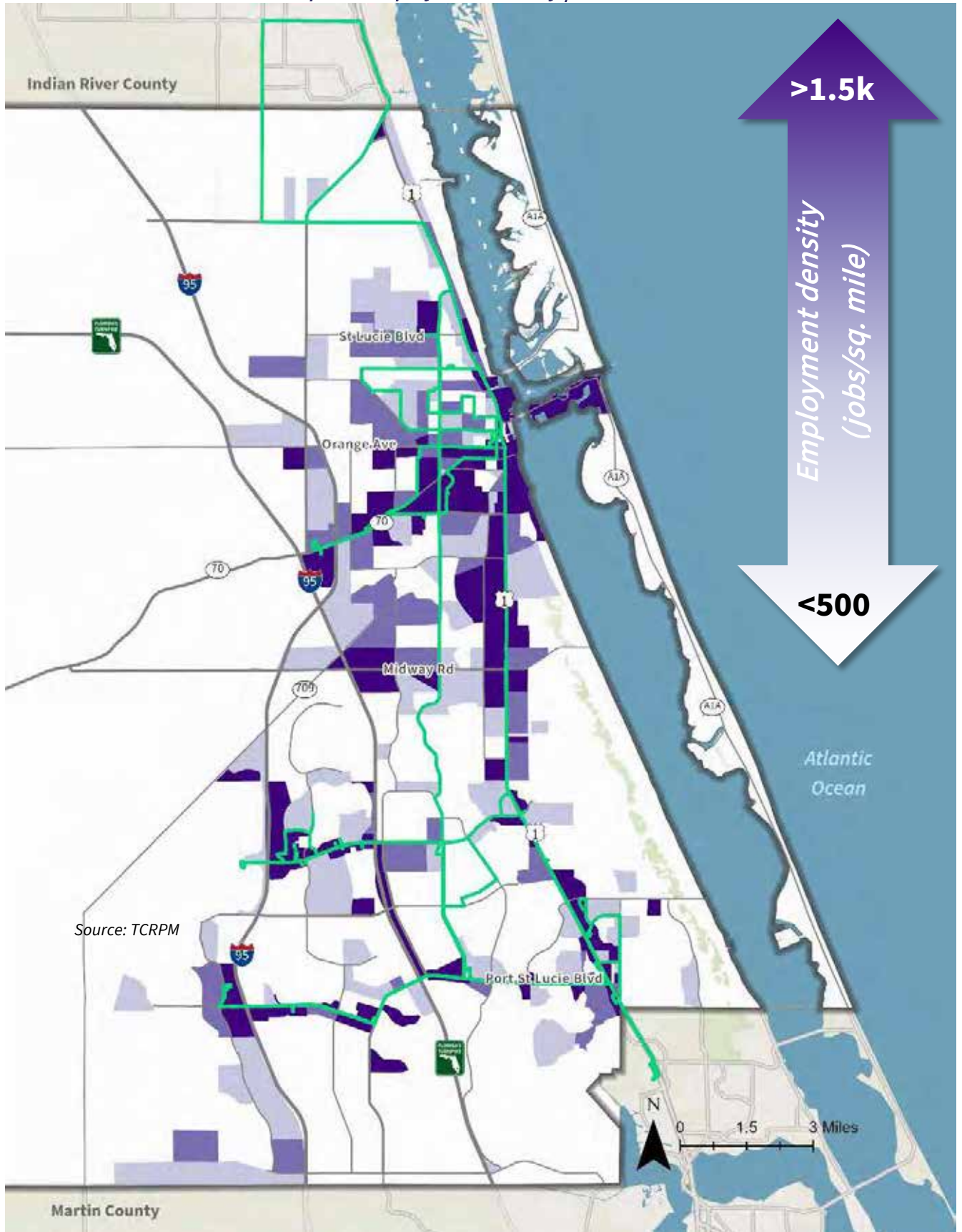

Map 2-5: Employment Density | 2034

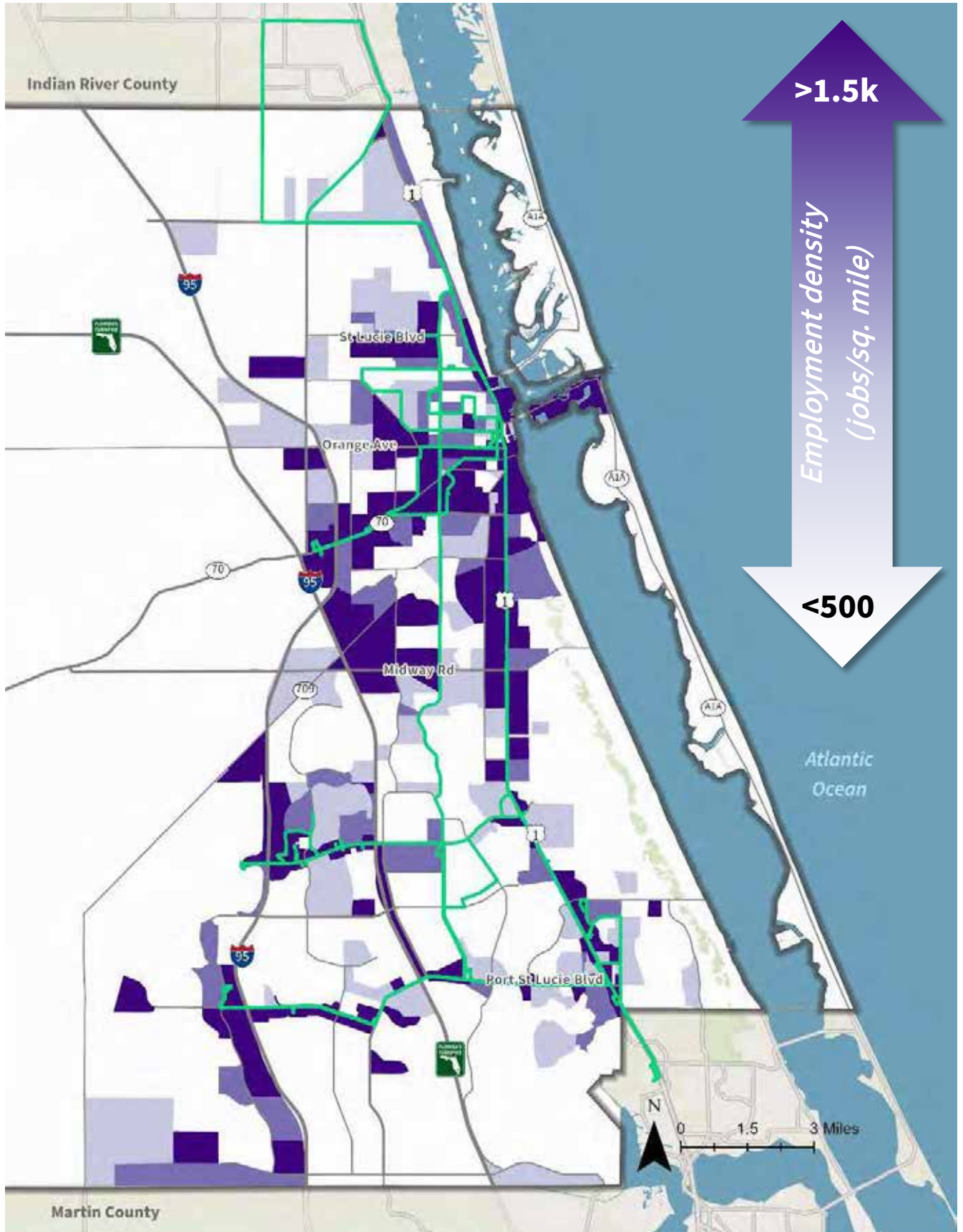

Households

Considering that transit demand is often greater where housing densities are higher, it is important to evaluate the housing profile, including current and projected housing densities in ART’s service area. St. Lucie County continues to grow, which is most noted by the continuous investment in housing developments in recent years. Higher projected growth, particularly in the Port St. Lucie area adjacent to Martin County, may be due to the proximity to economic opportunities and recreational activities in conjunction with also being more affordable than adjacent housing markets.

Figure 2-3: Housing Tenure | 2021

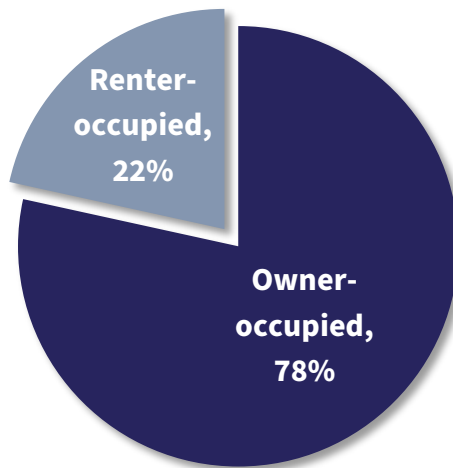

Source: ACS 5-Year Estimates (2017-2021)



Source: Visit St. Lucie

Map 2-7: Households Density | 2034

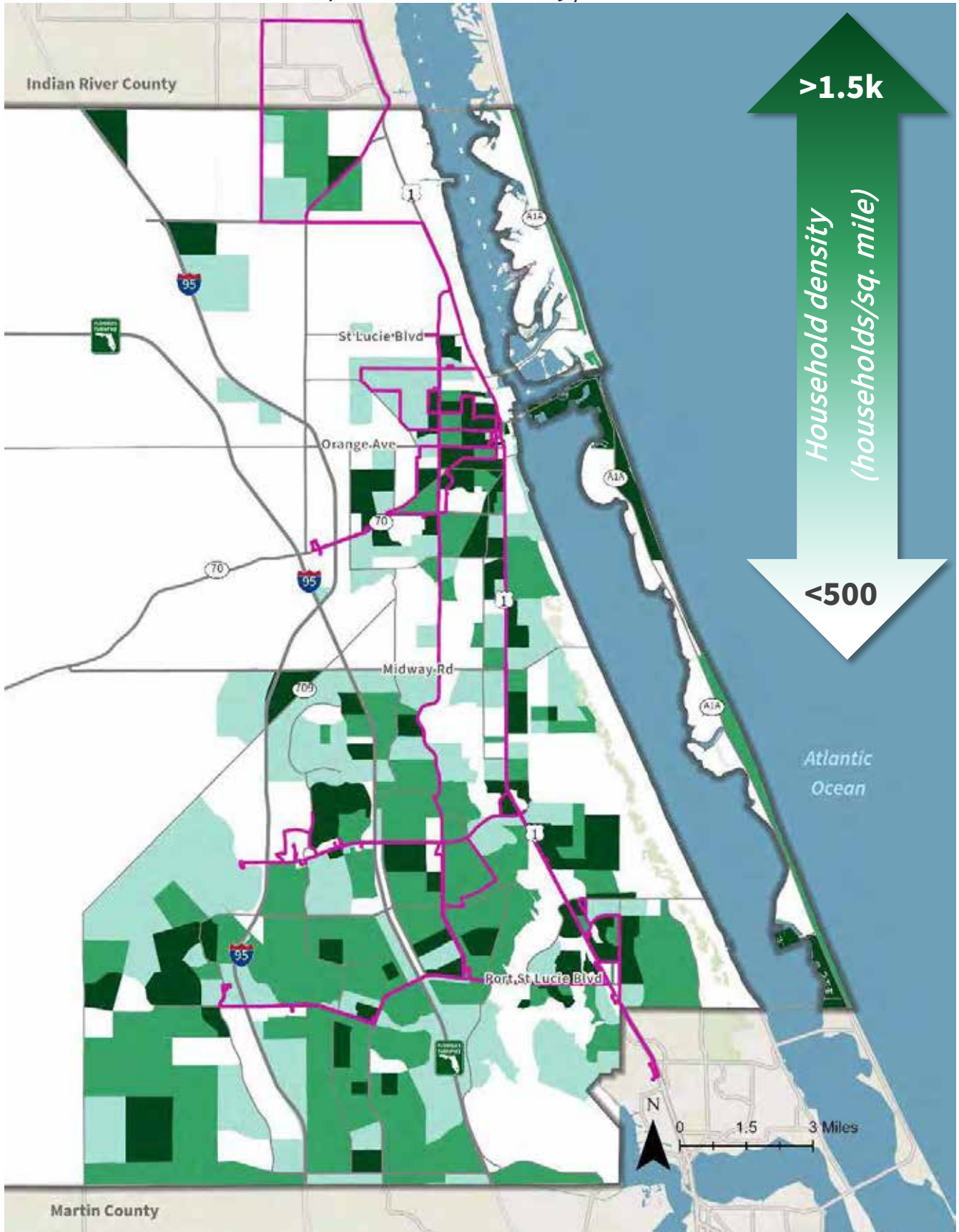

Socio-Demographic Characteristics and Trends

Age | Older Adults

By 2050, the percentage of older adult residents (65 or older) is expected to increase by 3%, to approximately 27% of the County’s population. This is an important consideration for transit as a person’s ability to drive is often reduced with age, leading to demand for other transportation options.

By 2050, 26.7% of the population will be 65+

In St. Lucie County, the high densities of older adult populations are primarily in Port St. Lucie west of I-95 and east of US 1 and on Hutchinson Island.

Figure 2-4: Percent of Older Adults (65+) | 2025-2050

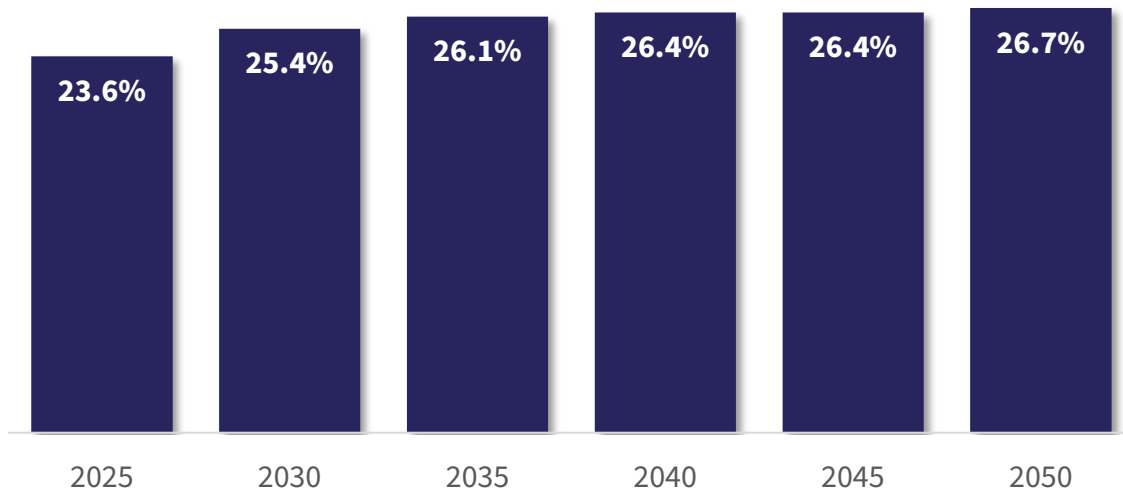

Source: BEBR

Map 2-8: Older Adults

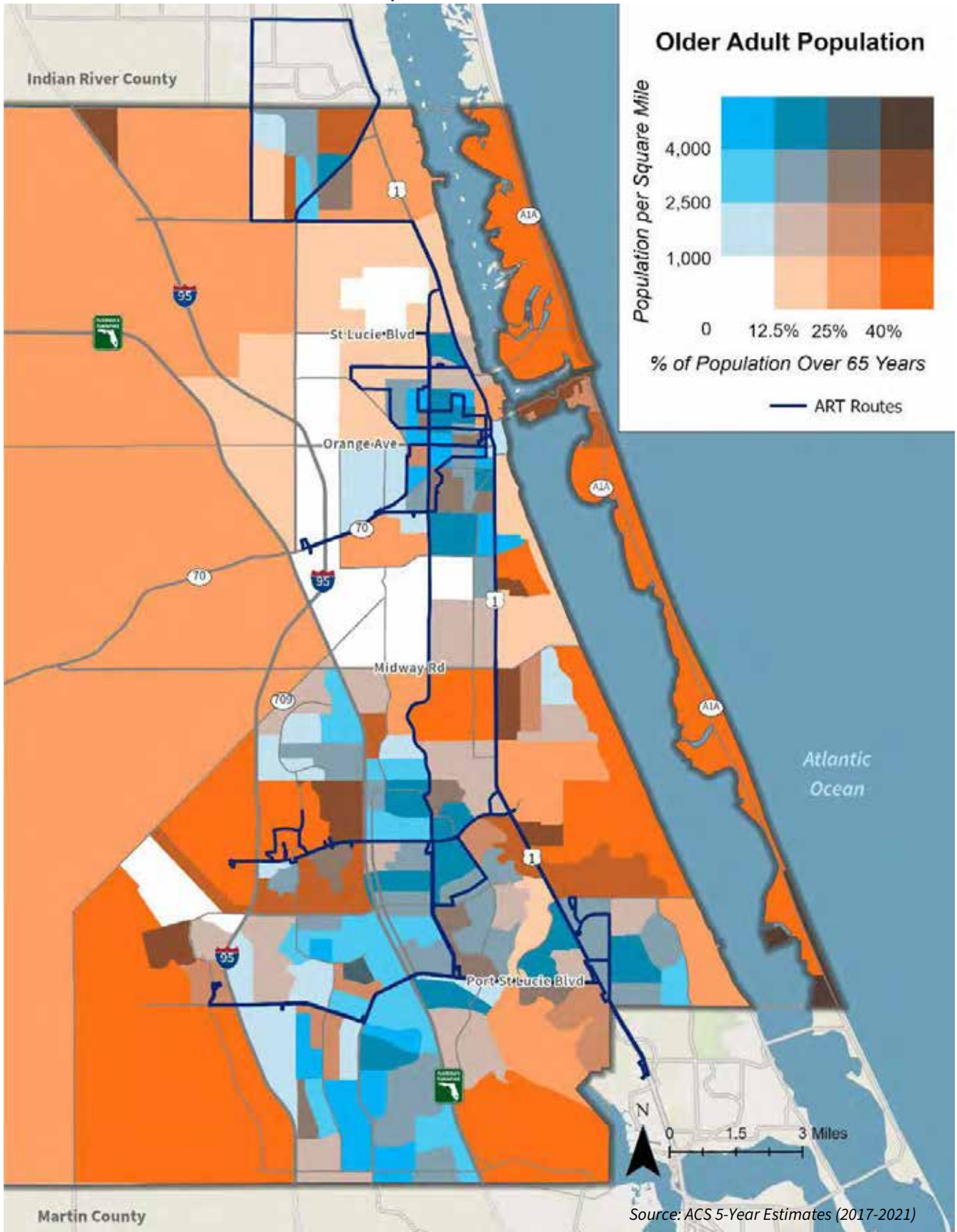

Age | Younger Adults

Millennials, or persons born between 1982 and 2000, generally exhibit a desire for different transportation modes and preferences than older generations. Millennials tend to drive less and desire more choices and flexibility in transit options. Younger adults born after Millennials, referred to as Generation Z, are continuing to exhibit these same preferences, indicating a more positive, long-term shift in transit habits.

The proportion of St. Lucie County residents age 25–54 is projected to decline marginally by 2050 (-1.3%). This age group represents most working-age residents and adult students, many of whom commute daily to school or work. This may indicate a need for additional transit mode options.

The most densely populated areas of the county (Fort Pierce and central Port St. Lucie) have a mix of block groups with both high and low concentrations of younger adults.

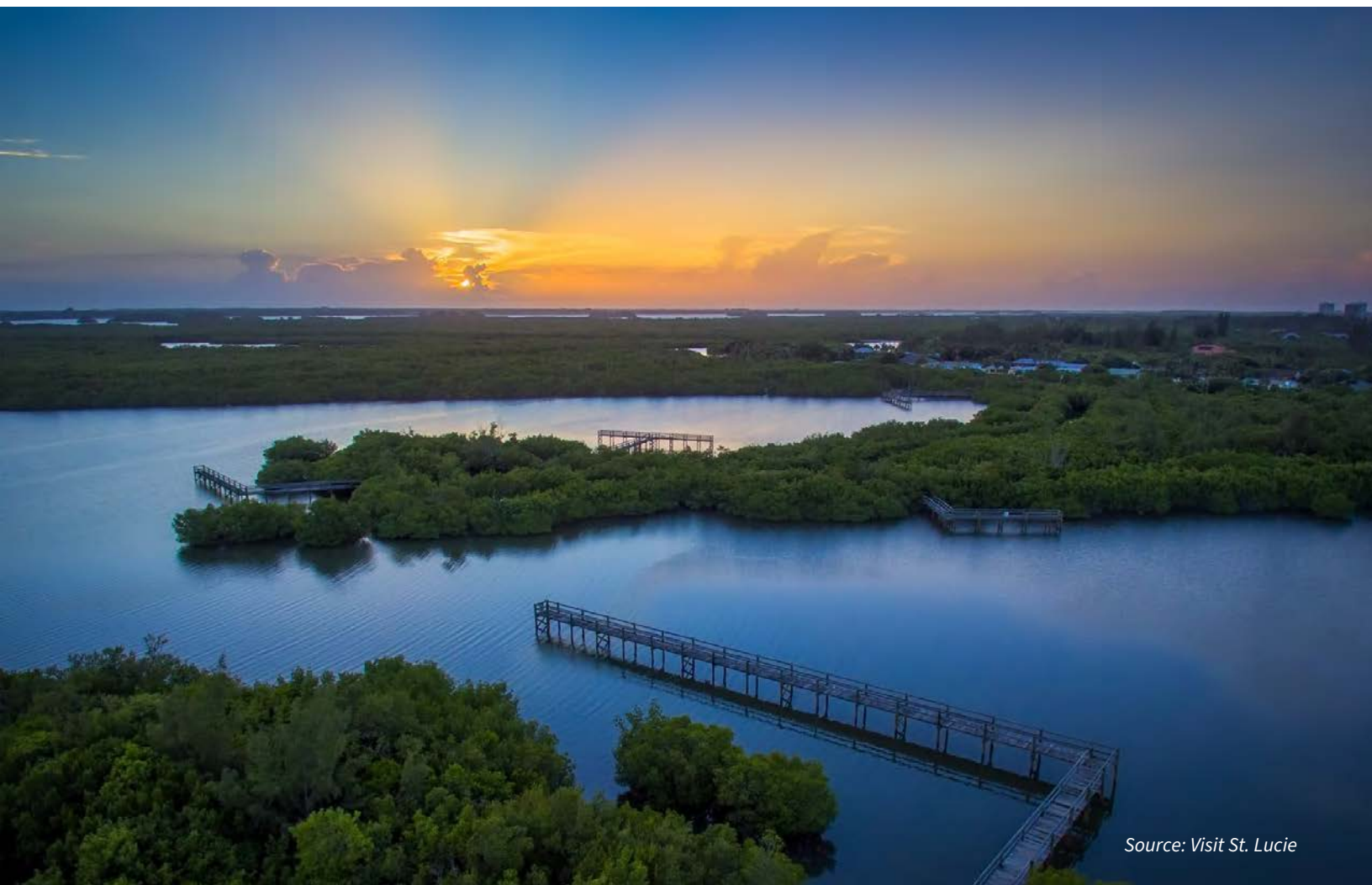

Source: Visit St. Lucie

Map 2-9: Younger Adults

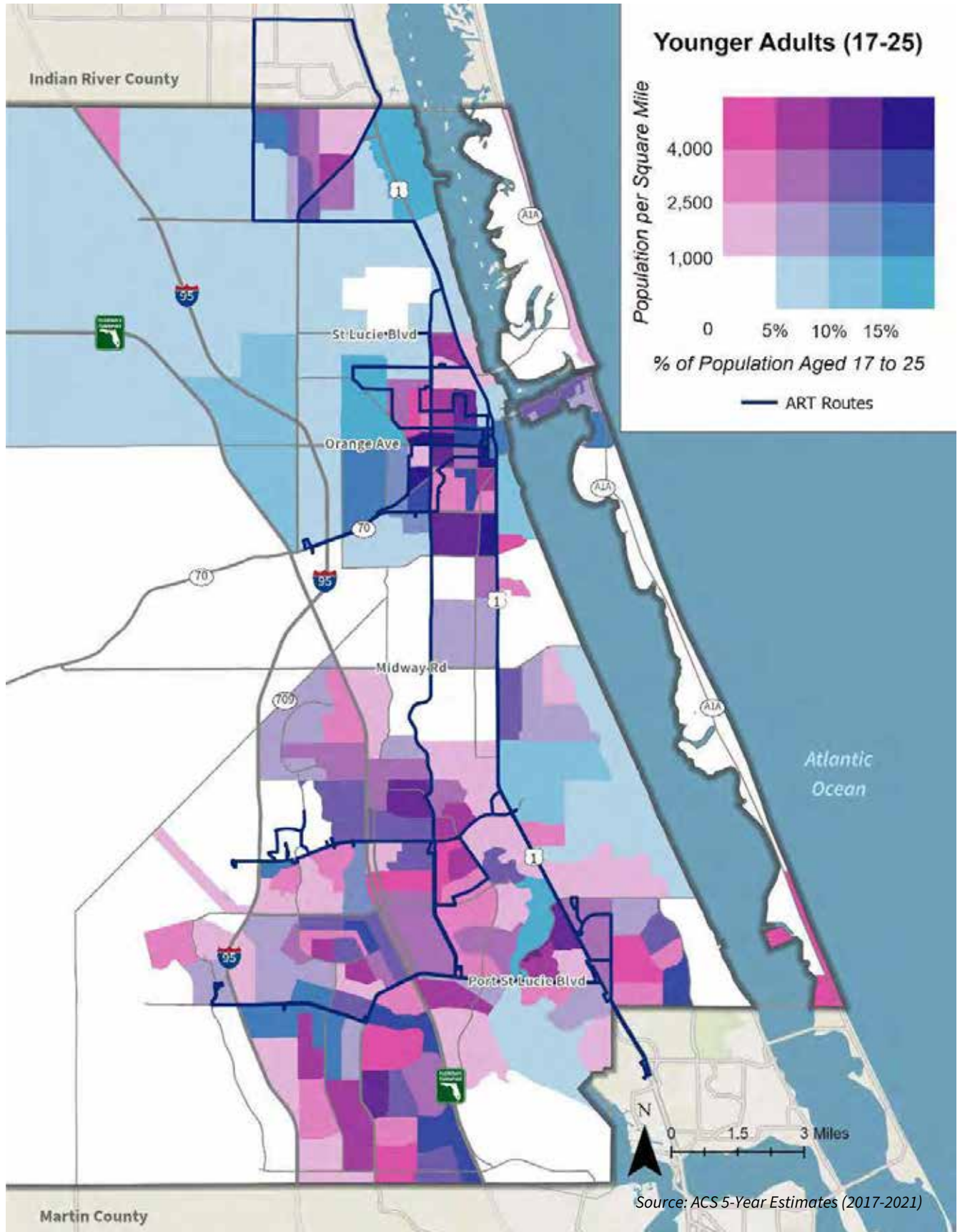

Income Distribution

Annual household income also can be a key indicator of potential public transit need, as low-income populations tend to use transit more than higher income earners.

Approximately 38% of households earned more than \$75,000 and 18% earned less than \$25,000 in 2021. Fort Pierce is densely populated with households living below the poverty level. Port St. Lucie has a mix of block groups with both low and high concentrations of households living below the poverty level. Unincorporated St. Lucie County also has many areas with higher concentrations of households living below the poverty level, although less concentrated than in the municipalities.

Figure 2-5: Household Income Distribution | 2021



Source: ACS 5-Year Estimates (2017-2021)

Map 2-10: Poverty

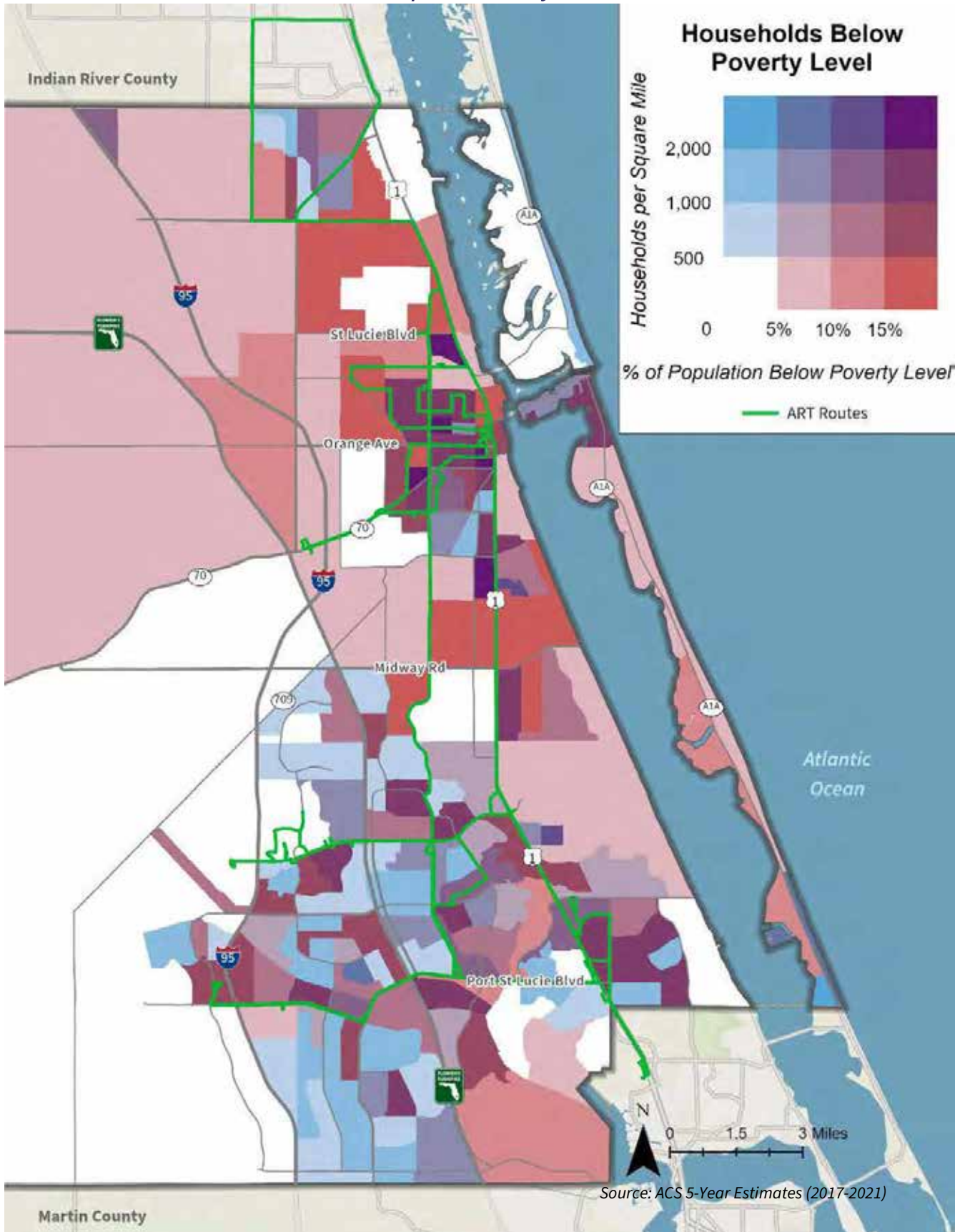

Individuals with Disabilities

Persons with disabilities may need public transportation service for their mobility needs if they cannot drive or walk long distances. Monitoring changes in the number and where the population with disabilities are located is important to ensure they are properly served. According to ACS 5-Year Estimates (2017-2021), 15% of the Lucie County’s population has a disability.

Households with one or more individuals with a disability are geographically spread out in St. Lucie County. The central part has a considerable percentage of individuals with a disability, although the population is not as dense as the core areas of Fort Pierce and Port St. Lucie, which have a mix of areas with high and low percentages of individuals with a disability.

Figure 2-6: Age Distribution of Individuals with Disabilities | 2021

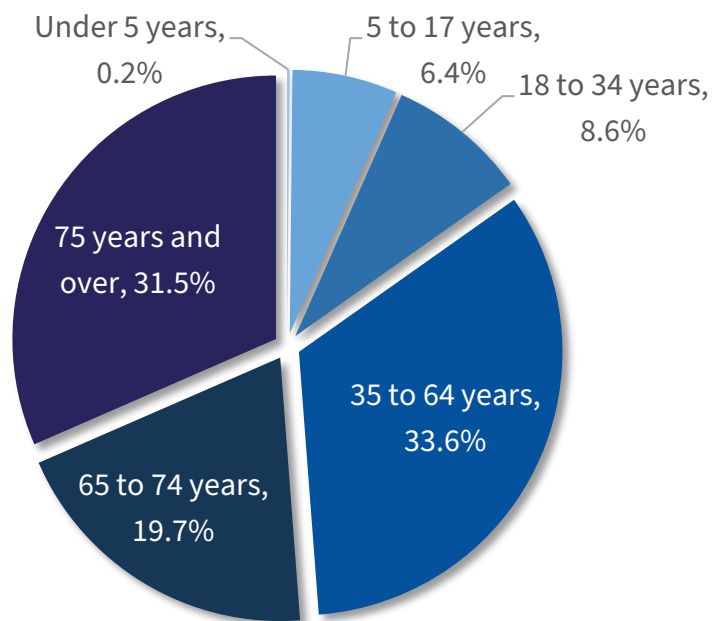

Source: ACS 5-Year Estimates (2017-2021)

Map 2-11: Households with Disabilities

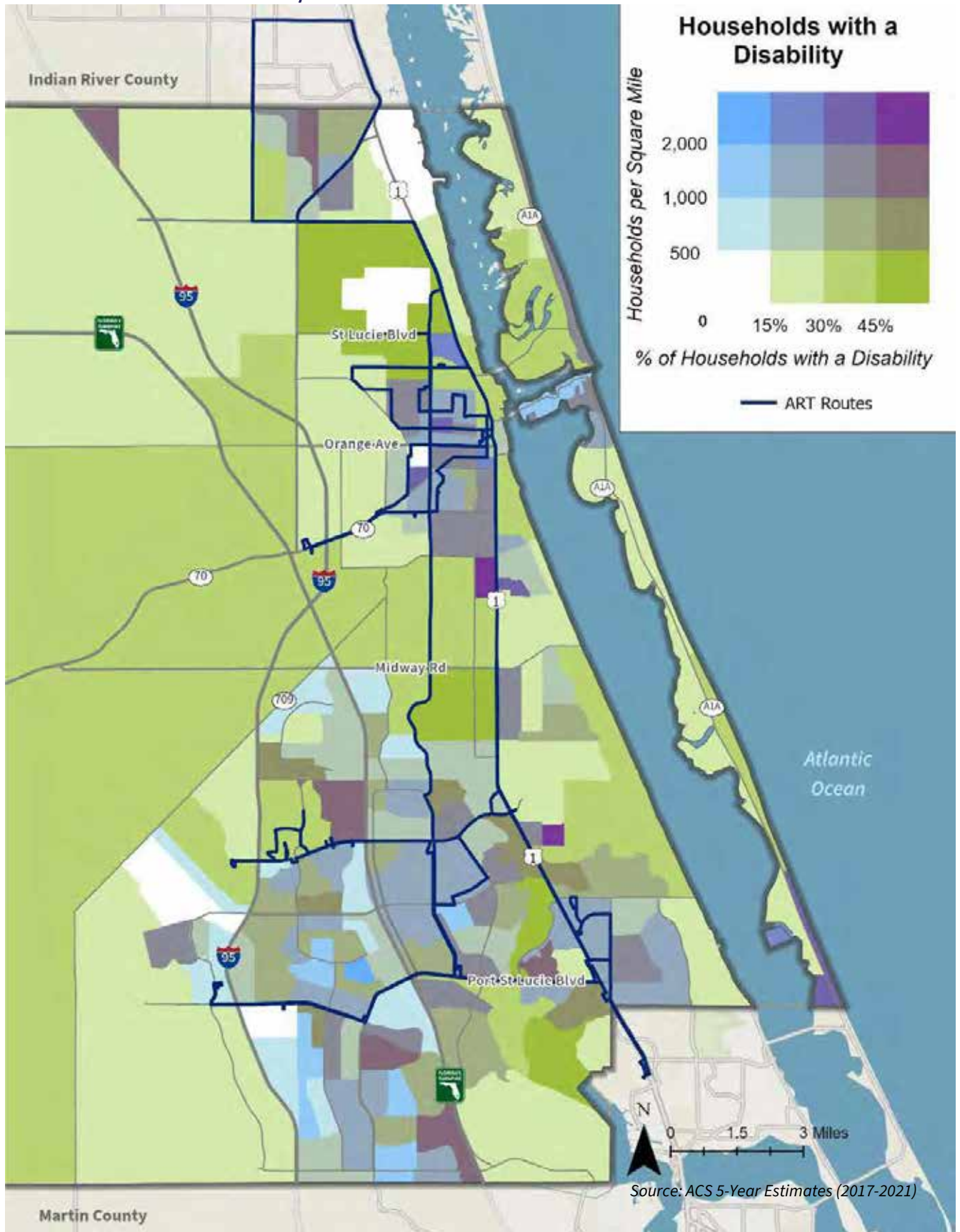

Educational Attainment

Education level is an important factor in understanding an area’s demographics. The level of education has been shown to correlate with income, which affects the propensity of the population to use public transit.

More than half of St. Lucie County residents, 57%, have some college credit or degree and 31% are high school graduates only. Educational attainment at the bachelor’s degree level is highest on Hutchinson Island and west of I-95. It is lowest in central Fort Pierce and outlying areas of Port St. Lucie.

Figure 2-7: Highest Educational Attainment

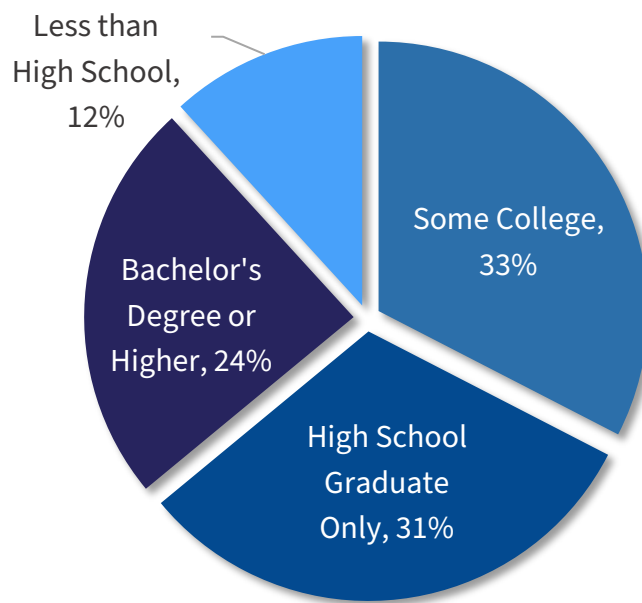

Source: ACS 5-Year Estimates (2017-2021)

Map 2-12: Educational Attainment

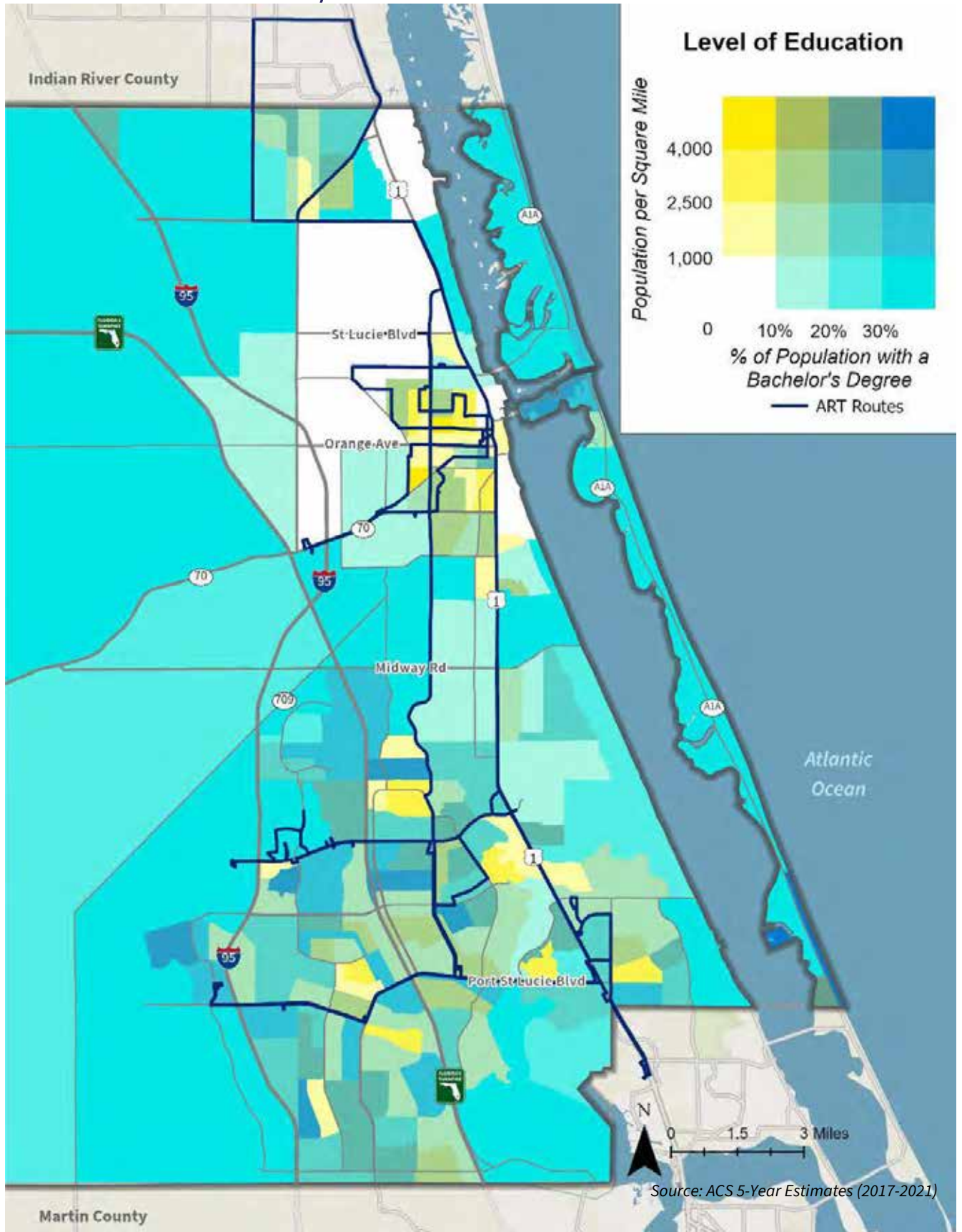

Race and Ethnic Origin

As transit remains a highly used mobility alternative among non-white and/or ethnic populations, it is important to identify the extent of those populations in St. Lucie. Currently, residents identifying as White alone (55%) comprise over half of St. Lucie County’s racial profile. Map 2-14 shows the location of non-White minorities throughout the County.

Fort Pierce has the most densely populated areas of minority groups. Southwestern Port St. Lucie is also populated by minority groups, but to a lesser density than in Fort Pierce.

Figure 2-8: Race and Ethnicity | 2021

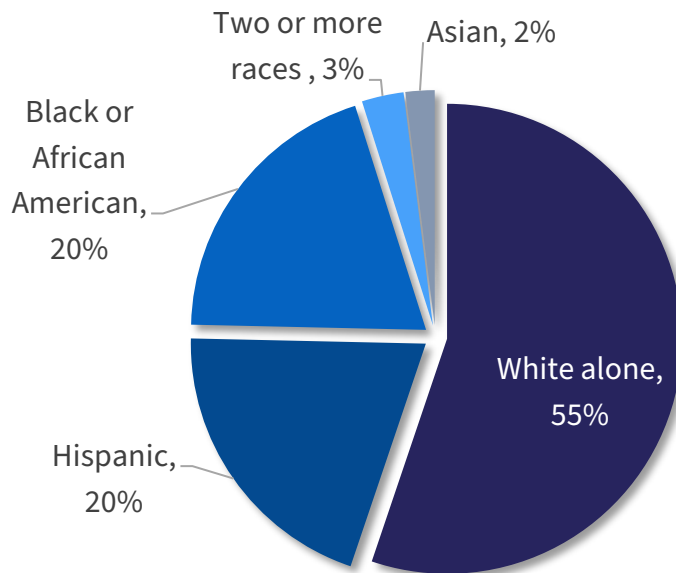

Source: ACS 5-Year Estimates (2017-2021)

Map 2-13: Race and Ethnicity

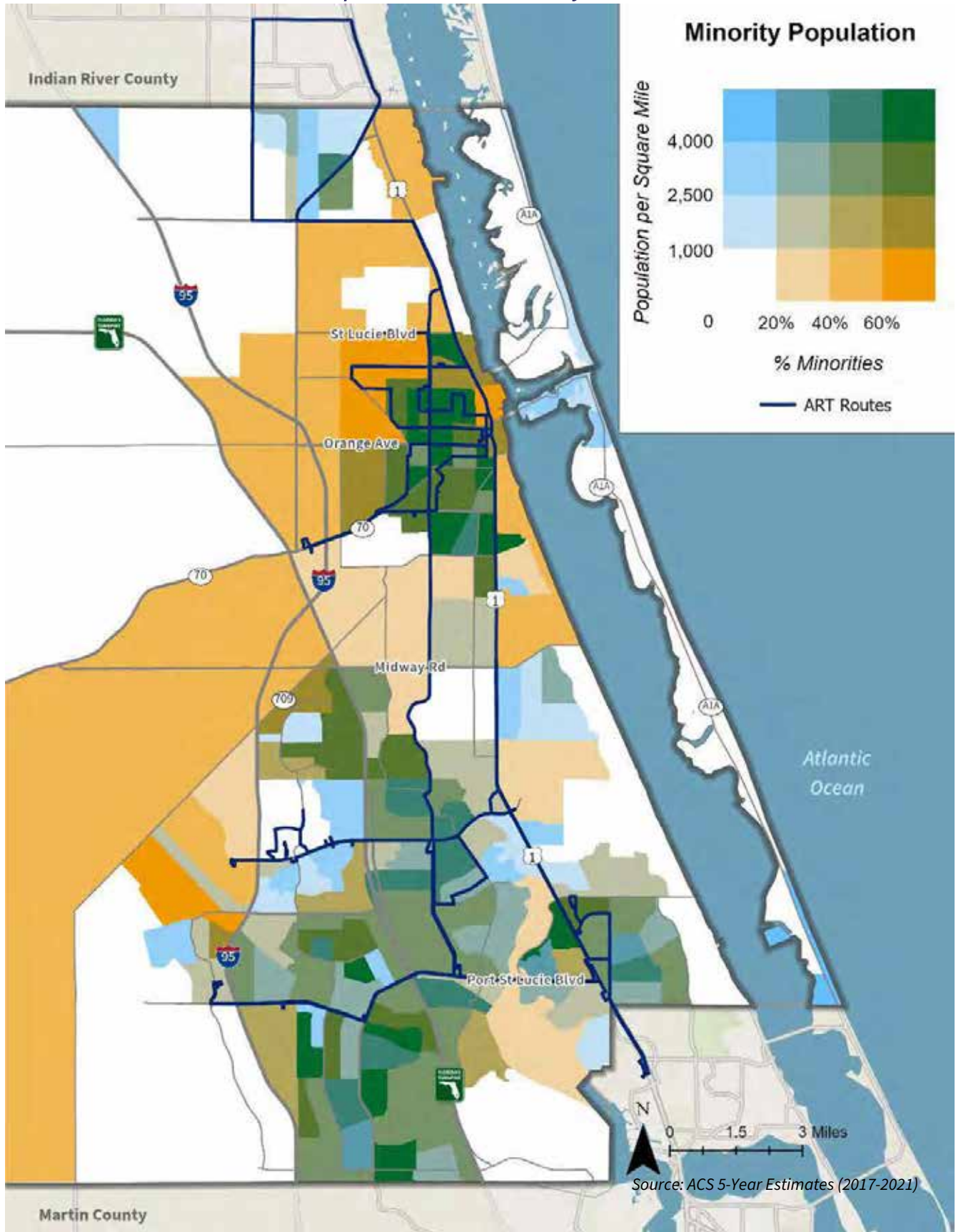

Limited English Proficiency

Transit may also provide St. Lucie County residents with Limited English Proficiency (LEP) additional travel options to services and jobs. According to the U.S. Census Bureau, LEP individuals are persons age 5 or older who self-identify as speaking English less than "very well." The total LEP population equals the sum of all individuals who speak a language other than English and speak English less than "very well."

The levels of LEP persons in St. Lucie County vary by block group. However, Fort Pierce and Port St. Lucie west of Florida's Turnpike contain a higher concentration of LEP households.

Figure 2-9: LEP Household Language Breakdown | 2021

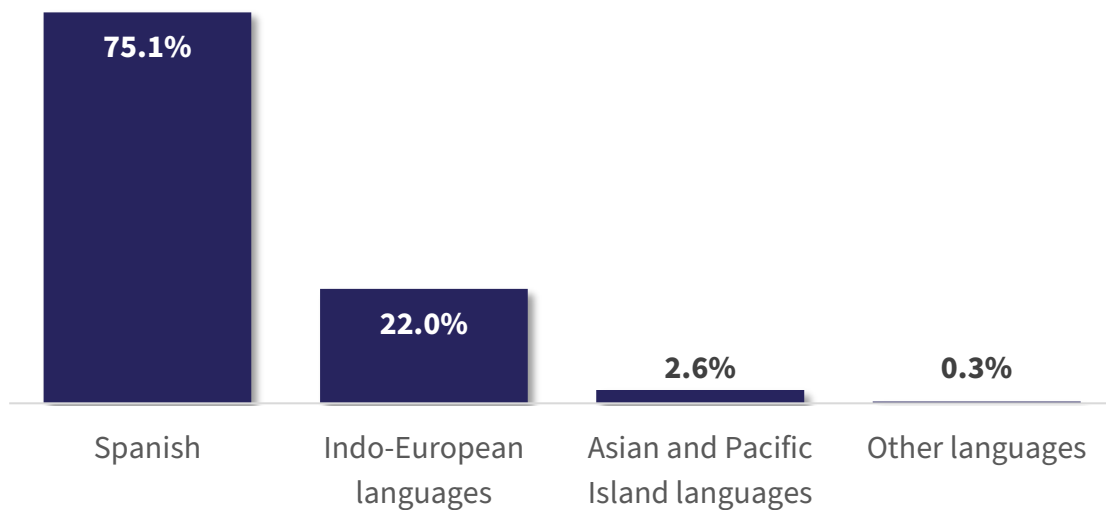

Source: ACS 5-Year Estimates (2017-2021)

Map 2-14: Limited English Proficiency

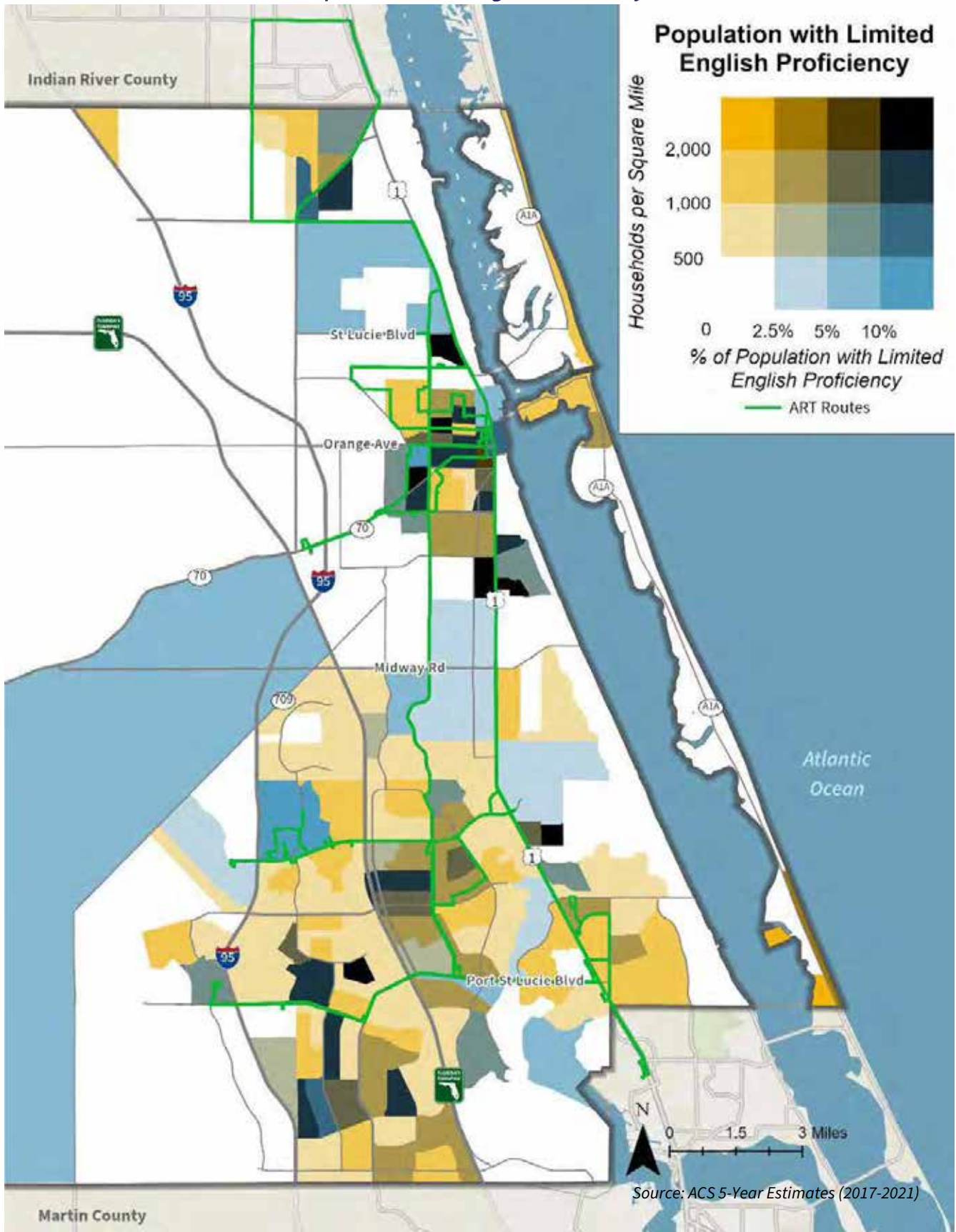

Automobile Ownership

Owning a vehicle can be a significant cost, particularly for households already near or below the poverty line. Households that do not own a vehicle, either because of unaffordability or by choice, are considered “zero-vehicle households” and are more likely to use transit for work, education, and recreational trips.

Most households in St. Lucie County have access to at least one vehicle and transit users are more likely to be zero or one-car households compared to all households. Most high-density areas of zero-vehicle households are in Fort Pierce.

Figure 2-10: Number of Vehicles Owned by Household | 2021

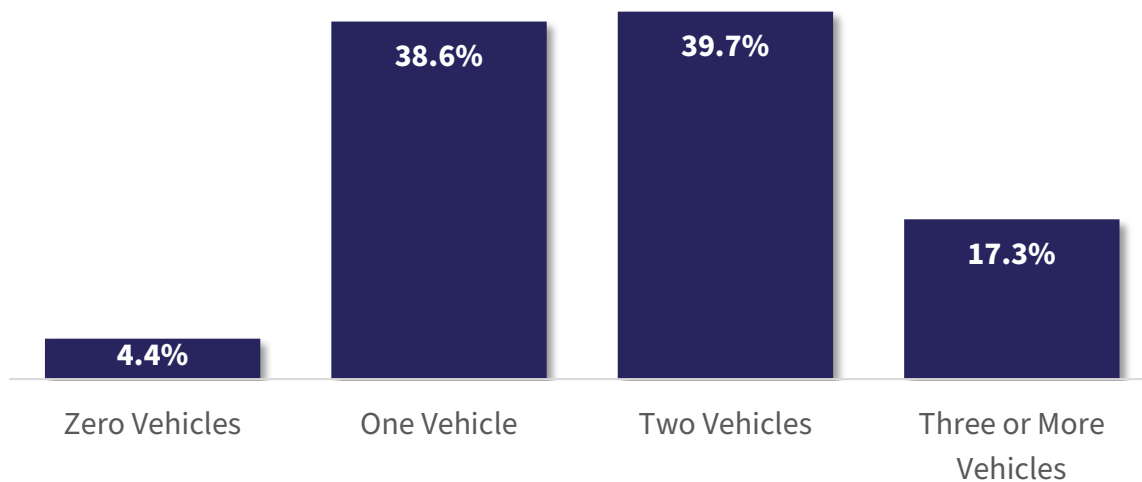

Source: ACS 5-Year Estimates (2017-2021)

Map 2-15: Zero Vehicle Households

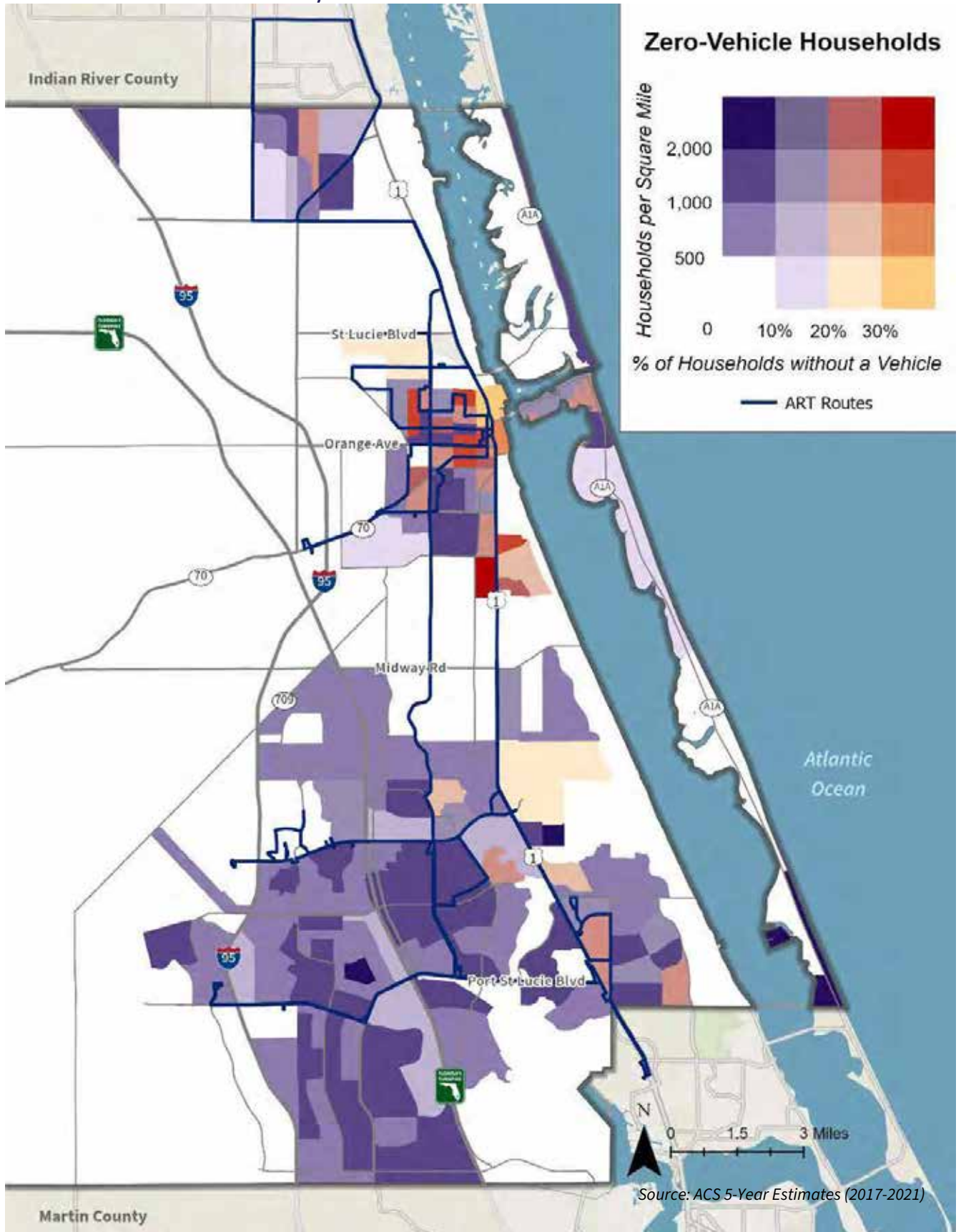

Travel Behavior and Commuting Trends

If offered as a viable and attractive option, transit can effectively connect residents to jobs and other activities across county lines. Data available from Longitudinal Employer-Household Dynamics (LEHD) “OnTheMap” tool developed by the U.S. Census Bureau, were analyzed to assess general travel patterns in and around St. Lucie County.

St. Lucie County has a strong economic connection with neighboring counties. This is evident in the exchange of workers who reside in one county but work in another. St. Lucie County houses more workers employed in neighboring counties than it employs workers residing in neighboring counties. The counties closest to St. Lucie by distance (Martin, Indian River, Palm Beach) typically have the largest commuter inflows and outflows.

Table 2-1: Commute Patterns / Inflow and Outflow

County	Inflow	Outflow
Martin	5,038	22,528
Palm Beach	1,408	14,155
Indian River	4,608	6,796
Broward	310	1,449
Brevard	1,159	773
Miami-Dade	133	743
Okeechobee	884	643

Source: LEHD “OnTheMap”

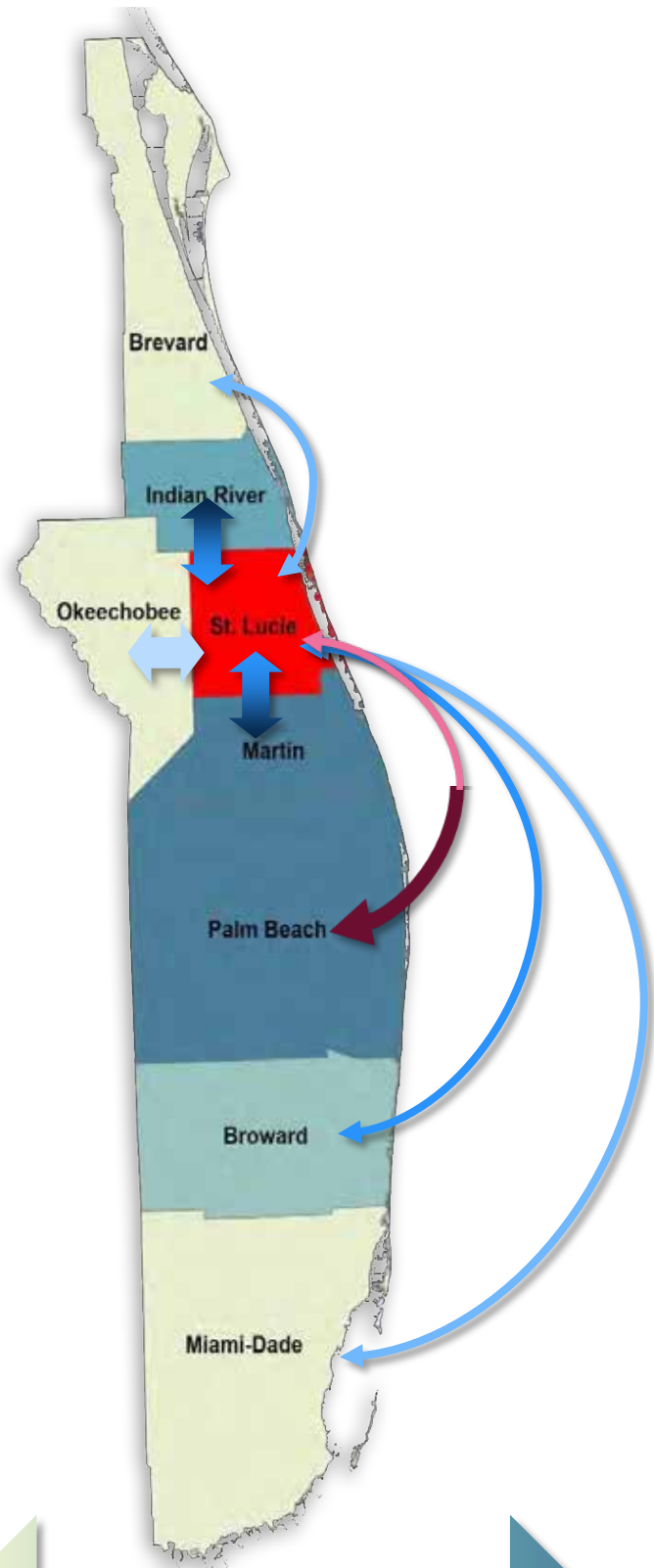

Commute Choices

Insight into St. Lucie County’s commuter profile, such as commute modes and length, is important to understand how transit may supplement the community’s travel options.

Most residents who commute to work drive alone (80.9%), which is like many suburban areas in Florida. The percentage who worked from home (7.0%) has increased since 2010.

Approximately 44% of commuters who drive alone leave between 7AM and 9AM. Among transit users, 72% leave for work at that time. Furthermore, 35% of commuters who use public transit have a trip of 60+ minutes. The most frequent commute length for those that drive alone is between 15 to 29 minutes (37.9%).

Figure 2-11: Commute Modes / 2021



35% of public transit users have a trip of over an hour.

38% of commuters driving alone have the most frequent commute length of 15-29 minutes.

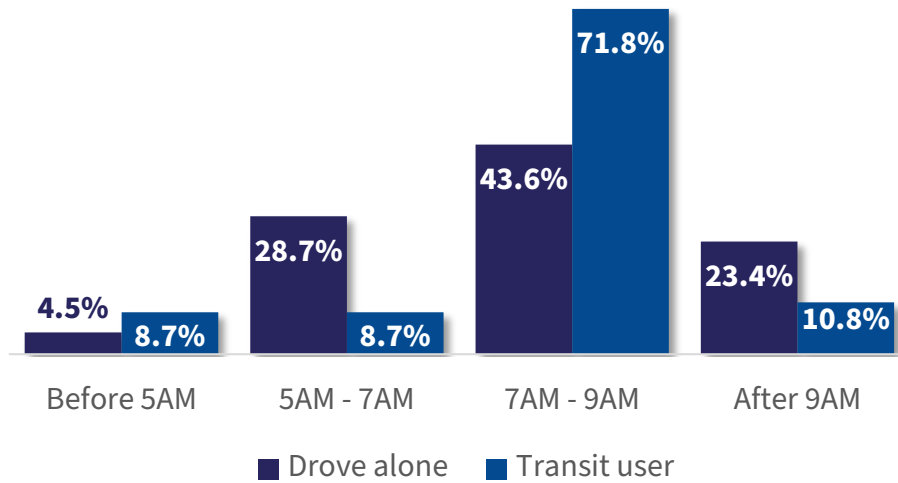

Source: ACS 5-Year Estimates (2017-2021)

Figure 2-12: Departure Time to Work | 2021



Source: ACS 5-Year Estimates (2017-2021)

Figure 2-13: Commute Time | Transit vs Drove Alone

	Less than 15	15-29	30-59	More than 60
	18.2%	37.9%	34.4%	9.6%
	3.1%	5.4%	56.6%	35%

Average commute time is 28.6 minutes

Source: ACS 5-Year Estimates (2017-2021)

Transportation Disadvantaged (TD) Population

St. Lucie County is also the designated Community Transportation Coordinator (CTC), providing travel options for people who cannot use fixed-route service and do not qualify for complementary ADA paratransit service. This door-to-door service is provided throughout the county for individuals with disabilities, who are age 67 or older, or who qualify as low-income from anywhere under the Transportation Disadvantaged (TD) Program. To use TD services, individuals must apply for and be approved.

TD service connects qualified individuals to lifeline trips for medical, employment, educational, nutritional, or other life-sustaining purposes. According to the Florida Commission for the Transportation Disadvantaged’s (TD) 2021 Annual Operating Report, the top trip purpose reported was medical (36.5%), which increased since 2017 (21.2%). Trips for education/training/day care purposes experienced a significant decrease, from 31.0% in 2017 to 22.2% in 2021.

Figure 2-14: TD Trips by Purpose |2021

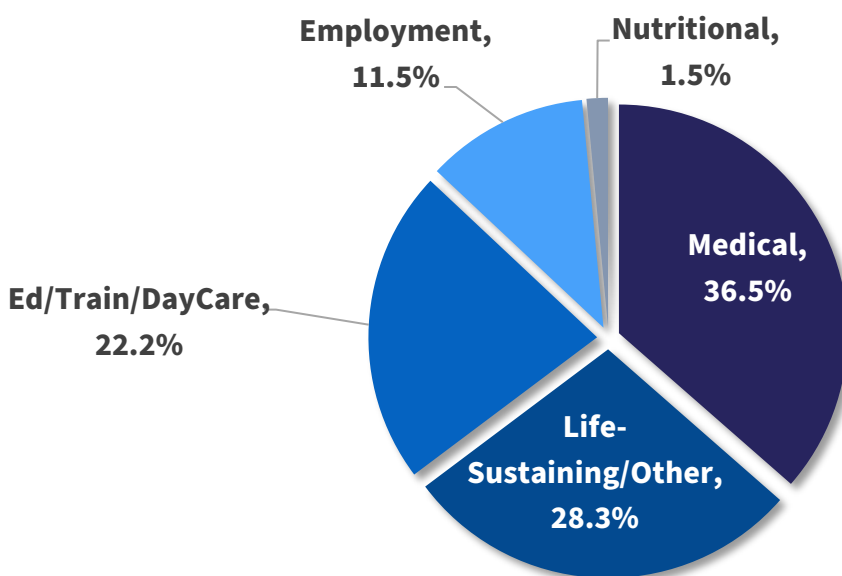

Source: Commission of Transportation Disadvantaged

Major Trip Generators

Major trip generators are places that attract or generate a lot of trips and often include medical facilities, recreational areas, educational establishments, major shopping centers, and government or business offices. Local major trip attractors are found throughout St. Lucie County, though typically located close to major roadways. Additionally, locations of event centers, schools, earning centers, and public parks were also reviewed as part of this analysis.

Major Trip Attractors

St. Lucie County operates Clover Park, the spring training home of the New York Mets, summer home of the St. Lucie Mets, and the hub for all New York Mets minor league operations. Outside of baseball, the sports complex hosts a variety of events ranging from festivals, concerts, tournaments, and more. The stadium's seating capacity is 7,800, indicating a potential need for transit connections to the facility during major events.

Large public parks and spaces also can be considered major trip generators as visitors and residents want to enjoy them. The eastern/coastal portion of the county is home to the Savannas Preserve, Fort Pierce Inlet, and Avalon State Parks. Savannas Preserve State Park offers hiking trails and recreational activities such as canoeing, kayaking, and fishing for visitors. Popular activities at Fort Pierce Inlet State Park include swimming, scuba diving, and picnicking. Avalon State Park boasts more than a mile of undeveloped beach front home to endangered sea turtles and is ideal for snorkelers and scuba divers. These parks are not adjacent to any existing fixed-route service.

Major hubs of shopping and retail are located throughout St. Lucie County, including the Town Center at St. Lucie West, the Landing at Tradition, and downtown Fort Pierce, attracting residents and visitors to the area. There are museums, a River Walk Center, and the Manatee Observation and Education Center in downtown Fort Pierce.

Source: St. Lucie County



Fenn Center

The Havert L. Fenn Center, located in Fort Pierce is an event facility that provides basketball/volleyball courts, 6 meeting rooms, and a Main Exhibit Hall/Gymnasium. The Fenn Center is an event center a part of the Fort Pierce Parks system. Currently, only Route 3 serves the Fenn Center. The route connects to Routes 1, 2, and 7 at the Fort Pierce Intermodal Center.

St Lucie County Fairgrounds

The St. Lucie County Fairgrounds, located on Midway Road, is host to the annual St. Lucie County Fair. The Fair is held from the end of February to the beginning of March. The Fair provides a 10-day educational experience for agriculture, horticulture, creative arts and crafts, sciences, and civics as well as entertainment.

Currently, no ART routes serve the area. Additionally, no private shuttle service is provided according to the Fairground’s website.

MidFlorida Event Center

The MidFlorida Credit Union Event Center is a multipurpose event center located off Walton Road, adjacent to US 1 in Port St. Lucie. The Event Center hosts many functions including concerts, banquets, artist exhibitions, holiday festivals, and the Strawberry Fest. In addition to cultural events, the Event Center holds an important civic function as a location for early voting and election day voting for local, state, and national elections.

Currently, the Event Center is served by Route 4. Route 4 also connects with Routes 5 and 6 at the Port St. Lucie Intermodal Center.



Source: St. Lucie County

Map 2-16: Shopping, State Parks, Event Centers

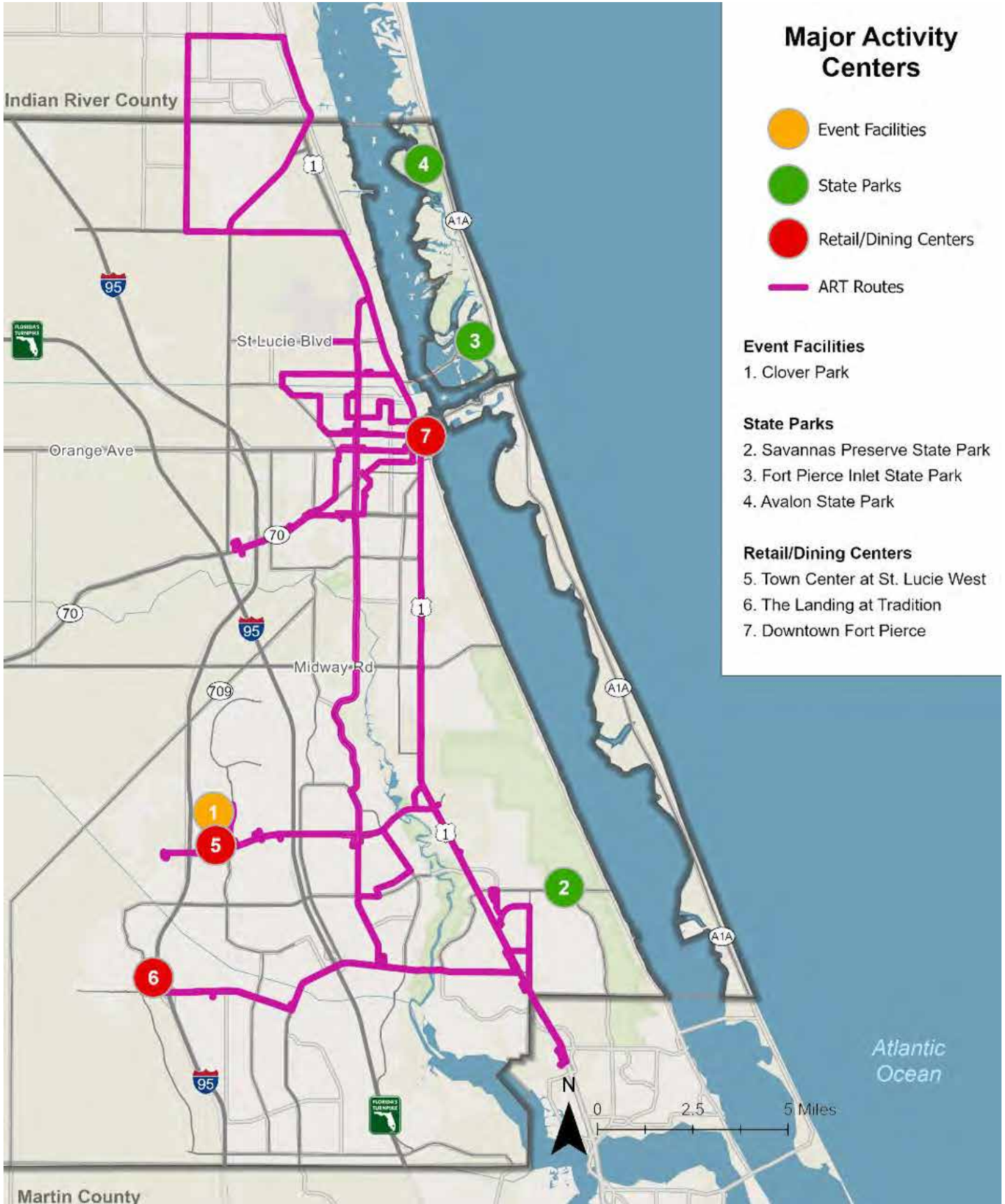

Major Employers

A key set of trip generators in an area is its major employers. Besides education, the top industry is healthcare, followed by local government. Some of the listed employers have multiple locations with employees distributed throughout the county, rather than in one location.

Table 2-2: Top 10 Major Employers

Employer	Type	# of Employees
St. Lucie Public Schools	Education	5,253
HCA Florida Lawnwood Hospital	Healthcare	1,847
Cleveland Clinic Martin Health	Healthcare	1,500
City of Port St Lucie	Government	1,363
Walmart Distribution Center	Distribution	1,273
HCA Florida St. Lucie Hospital	Healthcare	937
St. Lucie County	Government	791
Indian River State College	Education	734
Pursuit Boats	Manufacture	684

Source: St. Lucie County EDC



Higher Education Institutions

It is also important to examine the number and distribution of higher education centers as it is more common for students to not have access to a vehicle and possibly be more dependent on transit.

Indian River State College (IRSC) is the largest higher education institution in St. Lucie County. It serves over 22,000 students annually across 5 campuses and offers over 100 associate, bachelor, and technical educational programs. The main IRSC campus, Massey, is in Fort Pierce and Pruitt Campus is in Port St. Lucie.

Other higher education institutions in St. Lucie County include:

- Florida Atlantic University (FAU)—Harbor Branch
- Treasure Coast Medical Institute
- Barry University—Treasure Coast
- Fortis Institute—Port St. Lucie
- Keiser University—Port St. Lucie



Source: St. Lucie EDC

Map 2-17: Higher Education Centers

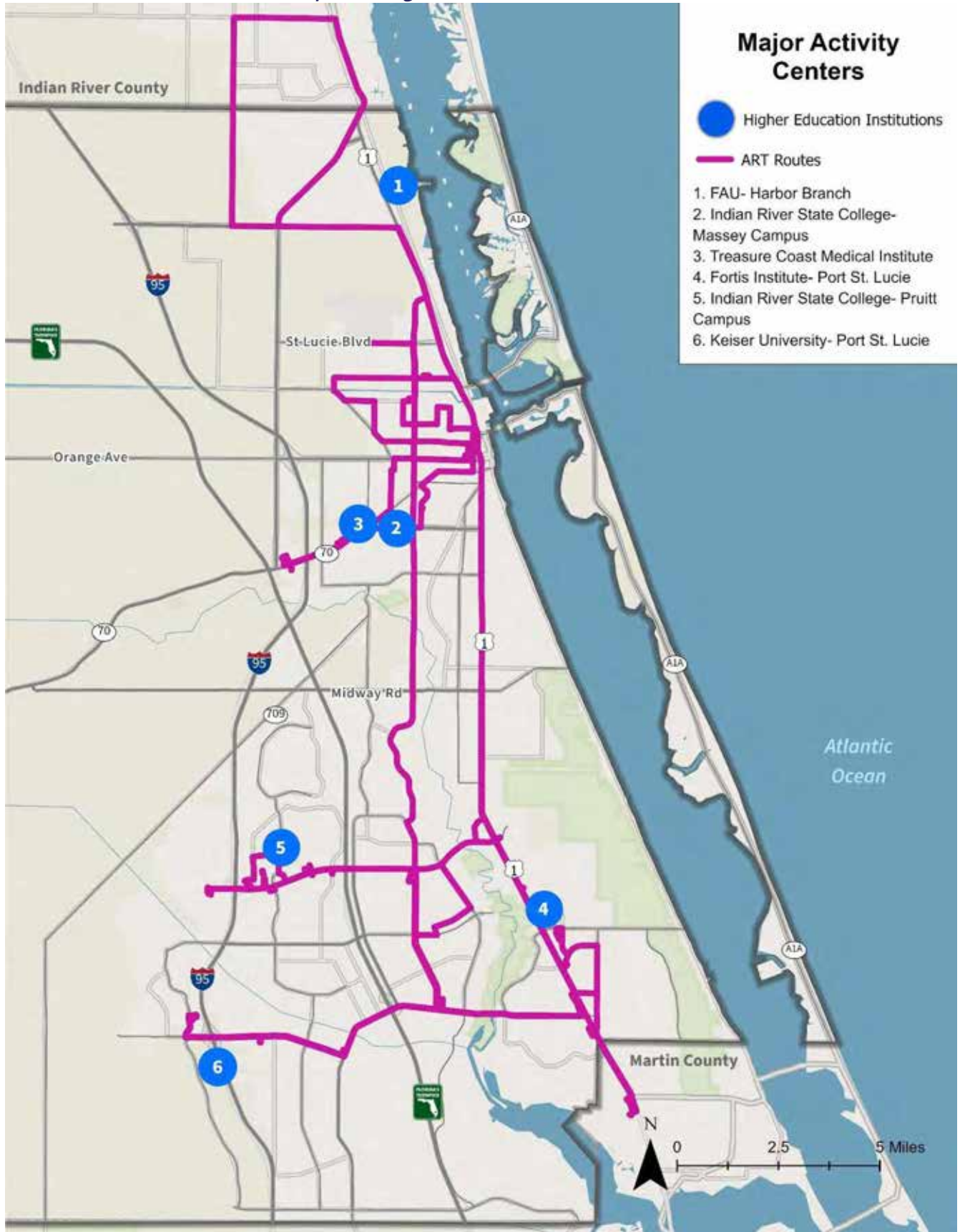

Tourism

Tourists are an important group of riders to consider when identifying local and regional transportation needs. Regional connections, such as to the major airports and activity centers, would be helpful, as transit costs less than renting a car and is convenient for visitors who do not want to or cannot drive. Many visitors come to St. Lucie County to enjoy beaches, nature, shopping, dining, and more. Most visitors (66%) travel to St. Lucie County by vehicle while 17% fly to Palm Beach International (PBI) Airport.

Impact of tourism on St. Lucie County

- *\$801,665,800 of economic impact*
- *\$520,562,200 is tourism spending*
- *1,195,560 of annual visitors*
- *1,173,424 of room nights by visitors*
- *\$8.6 million in local sales tax revenue*

Source: 2017 Visitor Tracking and Economic Impact Study by Visit St. Lucie

Source: Visit St. Lucie



Roadway and Traffic Conditions

A review of the Annual Average Daily Traffic (AADT) on St. Lucie County roadways was conducted based on the data available from FDOT. AADT, defined as the average volume of traffic on a section of roadway for a year, was included to assess congested roadways that may have opportunities to be better served by transit. Implementing transit on congested roadways may help decrease traffic, which can help reduce emissions and single-occupant vehicle miles.

In St. Lucie County, roads with the highest number of daily automobile trips are I-95, followed by Florida's Turnpike, US 1, Crosstown Parkway, Port St. Lucie Boulevard, and St. Lucie Boulevard.

Current and Future Land Uses

St. Lucie County

St. Lucie County coordinates land use and zoning for all unincorporated areas. Nearly the entire western half of St. Lucie County is designated for agricultural use. The rest of the unincorporated area is largely concentrated in the northeast, where much of the future land use is intended for Residential Urban and Towns, Villages, and Countryside.

Fort Pierce

In Fort Pierce, most of the land is designated for General Commercial use (concentrated along SR-70 and US 1) and Medium Density Residential, especially in the more established parts of the city. Additionally, land use is more intense in the Central Business District, located downtown.

Port St. Lucie

Most land area in Port St. Lucie is designated Low Density Residential. Farther from the established areas of the city are areas of open space and large swaths of land set aside for New Community Development.

Map 2-18: Roadway and Traffic Conditions

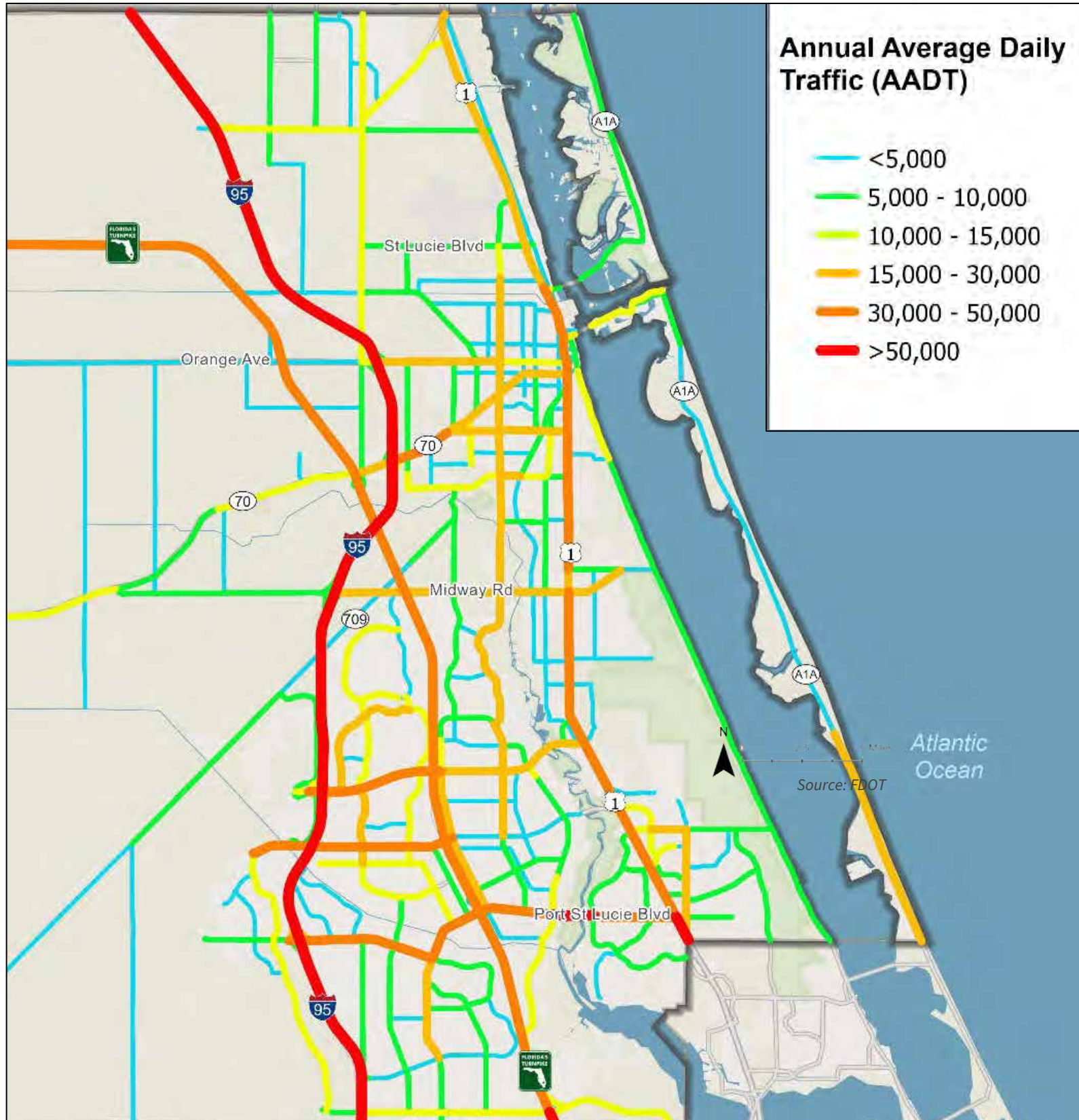

Map 2-19: Future Land Use / St. Lucie County

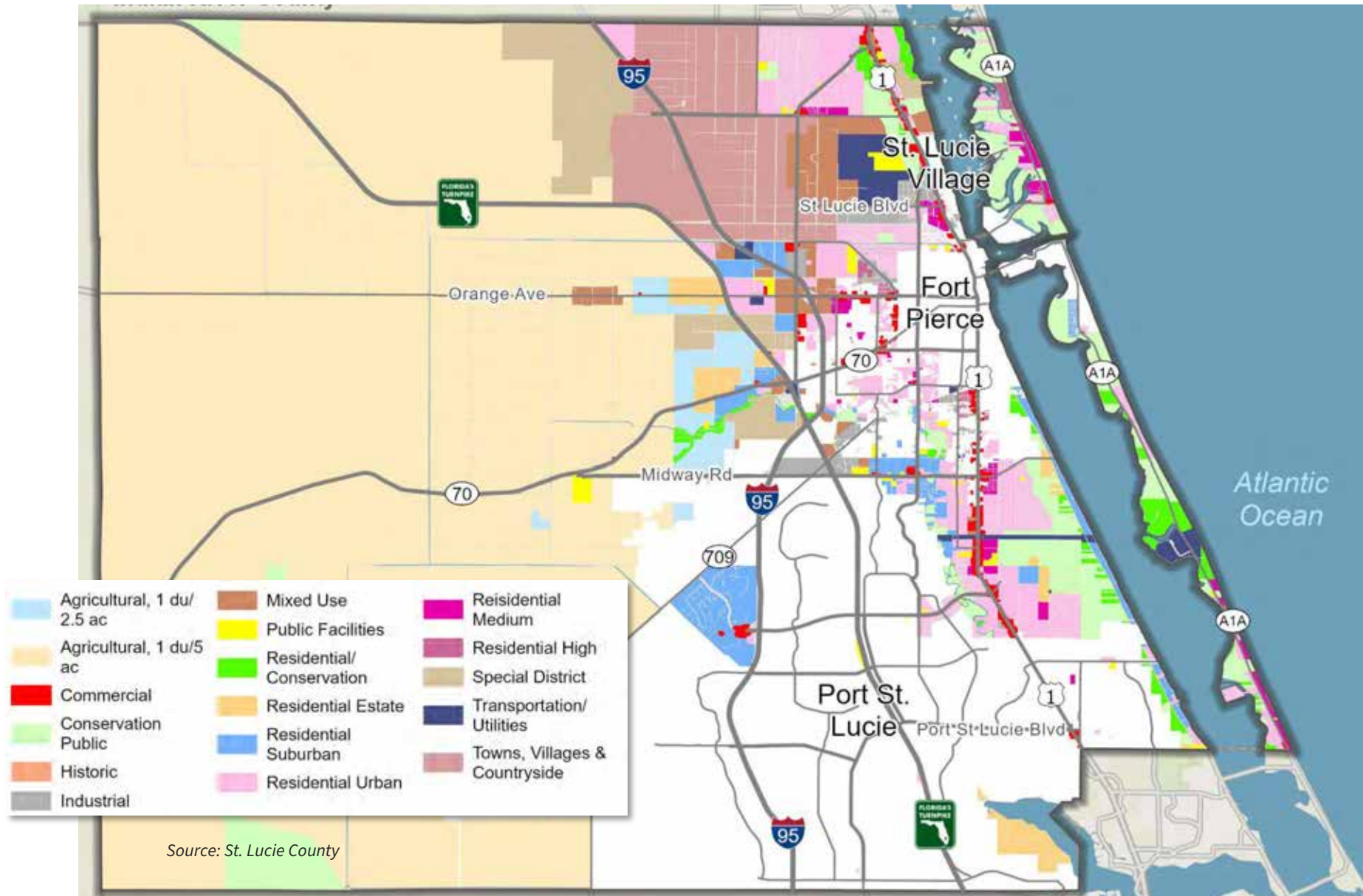

Map 2-20: Future Land Use | Fort Pierce

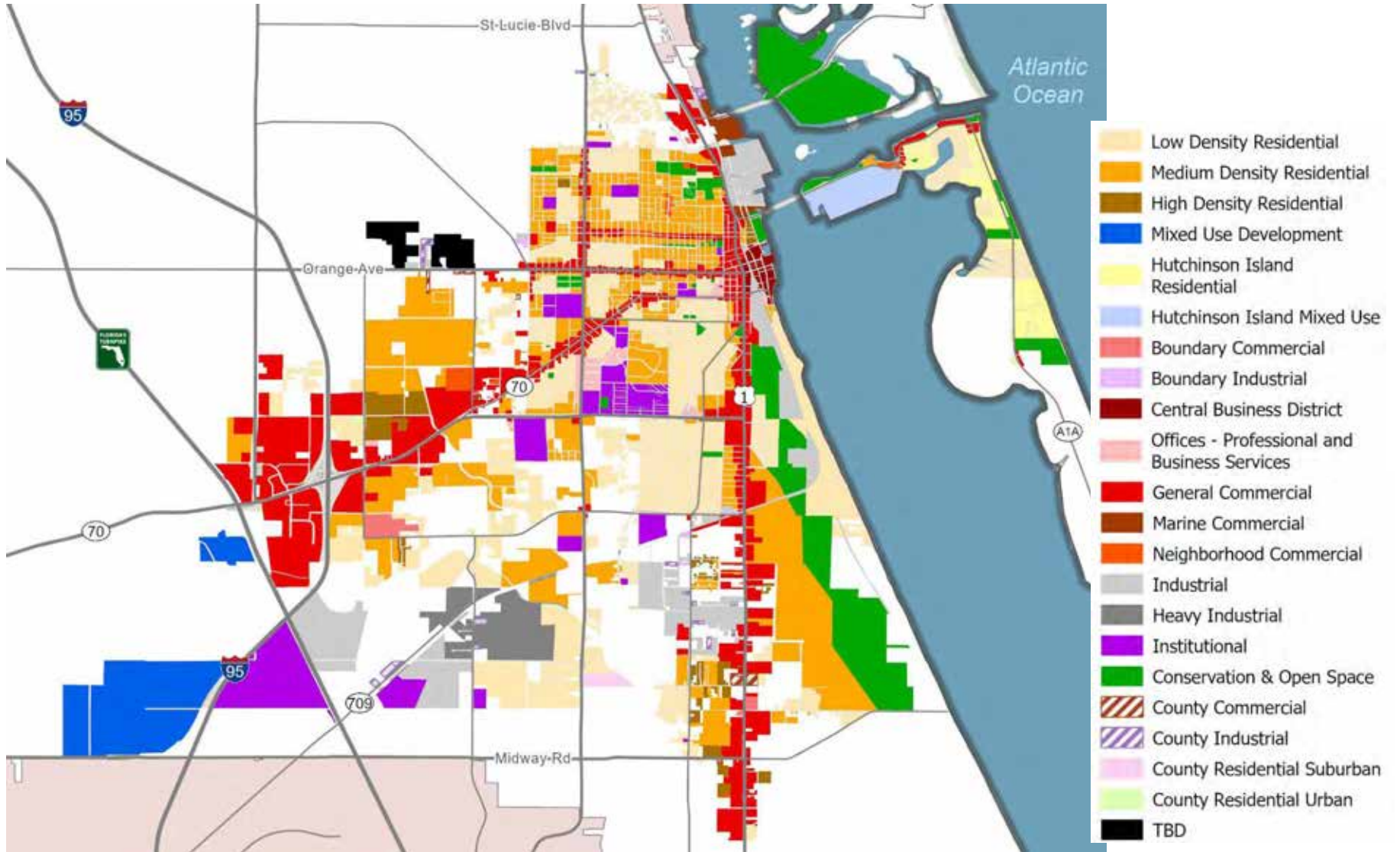

Map 2-21: Future Land Use / Port St. Lucie

- | | |
|---|--|
|  Commercial General |  Light Industrial |
|  Commercial Highway |  Residential - Office-Institutional |
|  Commercial Limited |  Highway |
|  Commercial Service |  Low Density Residential |
|  Institutional |  Medium Density Residential |
|  Heavy Industrial |  Residential Golf Course |
|  High Density Residential |  SLC Residential Urban |
|  New Community Development |  SLC Mixed Use |
|  Mixed Use |  SLC Transportation Utility |
|  Preservation Open Space |  Office |
|  Recreation Open Space | |
|  Conservation Open Space | |

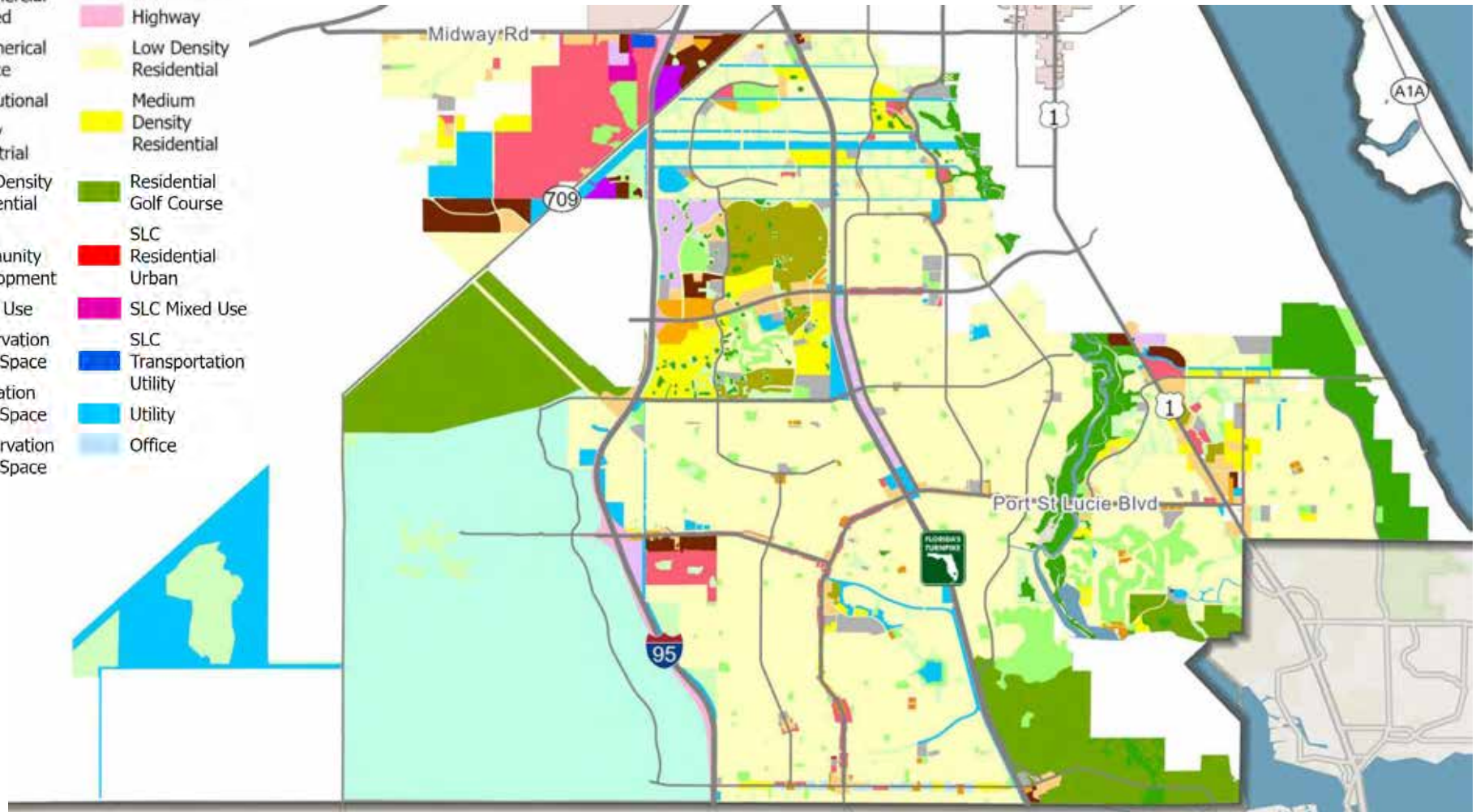

Section 3. Existing Transit Services

This section provides an overview of the public transportation services and facilities provided by ART. In addition to fixed-route services, ART also provides on-demand microtransit services and federally-mandated complementary Americans with Disabilities Act (ADA) paratransit service to those eligible.

Information on providers of other public transportation services in St. Lucie County also is summarized to provide a comprehensive picture of the available services.

Furthermore, results of trend and peer analyses using key performance indicators/measures for ART’s fixed-route services also are summarized. These assess how efficiently ART supplies its transit service and how effectively those services meet the needs of the community.

Transit Services Profile

ART provides fixed-route and ADA paratransit services to St. Lucie County in Port St. Lucie, Fort Pierce, and parts of unincorporated St. Lucie County. Additionally, it also provides regional transit connections to Indian River and Martin counties.

Fixed-Routes

ART’s fixed-route bus network includes eight routes. There are six routes that operate Monday through Saturday, while two operate Monday through Friday. All routes are operated every hour on weekdays. Routes 2, 3, and 7 primarily serve the Fort Pierce area and Routes 4, 5, 6 primarily serve Port St. Lucie. Routes 1 and 8 connect various areas north-south throughout St. Lucie County. Route 1 connects Fort Pierce to the Treasure Coast Mall in Martin County and Route 7 connects Fort Pierce to a transit hub in Indian River County.



All ART routes currently operate at 60-minute headways. Route 1 operated with 30-minute headways until 2020 but changed to hourly due to decline in demand from the pandemic and ongoing driver shortages.

Table 3-1: Fixed-Route Service Characteristics | 2023

Route	Weekday		Saturday	
	Headway	Service Span	Headway	Service Span
1	60	6:00 AM -8:00 PM	60	8:00-12:00 PM & 1:00-4:00 PM
2	60	6:00 AM -8:00 PM	60	8:00-12:00 PM & 1:00-4:00 PM
3	60	6:00 AM -8:00 PM	60	8:00-12:00 PM & 1:00-4:00 PM
4	60	6:00 AM -8:00 PM	60	8:00-12:00 PM & 1:00-4:00 PM
5	60	6:00 AM -8:00 PM	60	8:00-12:00 PM & 1:00-4:00 PM
6	60	6:00 AM -8:00 PM	60	8:00-12:00 PM & 1:00-4:00 PM
7	60	7:00 AM -6:00 PM	-	-
8	60	7:00-11:00 AM & 3:00-7:00 PM	-	-

Source: ART

Microtransit

Microtransit is an on-demand curb-to-curb service provided by ART within the designated zones. It can be hailed through an app or via phone and uses ADA-compliant vehicles to transport the customer within the designated zones. ART established its first microtransit zone, the South Zone, in March 2022 serving southwest Port St. Lucie. In September 2023, the service was expanded to St. Lucie West/Torino area, known as the North Zone.

The service operates Monday through Friday from 6:00 AM - 8:00 PM and Saturdays from 7:00 AM -4:45 PM. Passengers can connect to any destination within a zone or connect to the other zone via the three connection points listed below:

- Port St. Lucie Intermodal Center
- The Bayshore Park & Ride
- The Jobs Express Park & Ride

Map 3-1 shows ART’s fixed-route and microtransit services along with other facilities described later.



Map 3-1: ART Existing Services

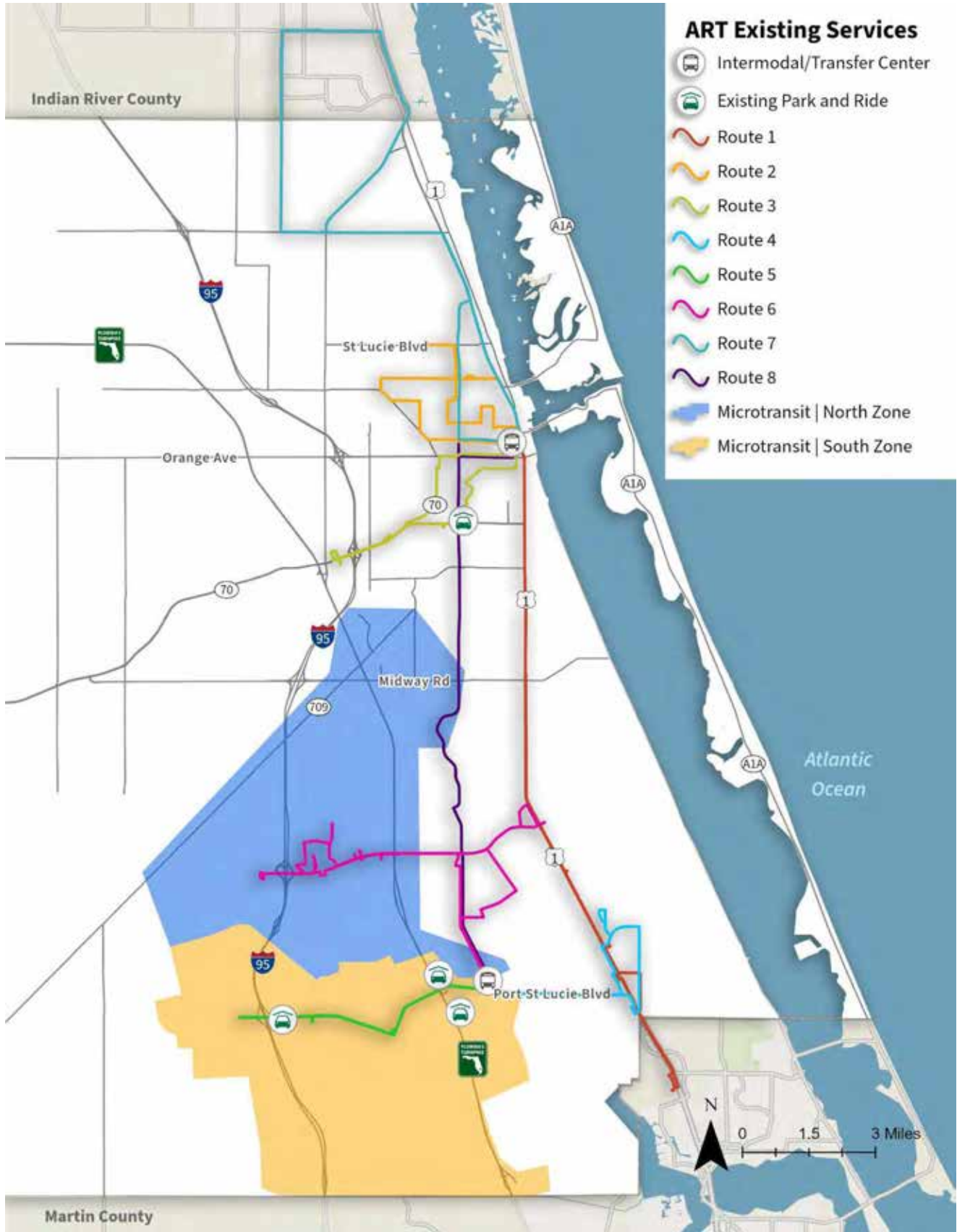

ADA Complementary Paratransit

ART also provides demand response transit service to persons qualifying under the ADA. These services are provided to residents who live within 3/4 mile of the fixed-route system but unable to access or ride fixed route due to an eligible disability.

ART certifies a person as eligible for ADA paratransit service under one of the following categories:

- Category 1: Persons who, because of their physical, visual, mental, or emotional impairment, cannot board, ride, or disembark from an accessible vehicle.
- Category 2: Persons who can independently use an accessible bus, but none are available some or all of the time.
- Category 3: Persons who have a specific impairment that prevents them from accessing a stop within the service area.

Additionally, passengers will be assigned an eligibility category: unconditional, conditional, and temporary.

Advantage Ride

Funded by the State of Florida, Advantage Ride is a local and regional service that provides safe, reliable, and accessible services for individuals with intellectual or developmental disabilities. Those who are interested fill out a form which prompts staff to contact the individual to complete an application. Currently, those who qualify for the service can travel anywhere in Indian River, Martin, St. Lucie, or Okeechobee counties if the ride originates or ends in St. Lucie County.

Transportation Disadvantaged Paratransit

St. Lucie County is the designated Community Transportation Coordinator (CTC) and is responsible for coordinating and/or providing transportation to individuals eligible under the Florida Transportation Disadvantaged (TD) program due to age, income, disability, or lack of access to other transportation options. TD service connects qualified individuals to medical, employment, educational, nutritional, or other life-sustaining trips.

Direct Connect

The Direct Connect program was developed in 2016 to help fixed-route and paratransit riders get to and from jobs, college classes, or medical appointments when fixed-route and paratransit service are not available, such as in early mornings, evenings, and weekends. To qualify for Direct Connect services, applicants must first be TD as defined in the Transportation Disadvantaged Service Plan (TDSP)¹ and be 18 years or older.

¹ Persons who are 67 years or older or; cannot ride fixed-route due to a disability or; income is below 200% of the Federal Poverty Guidelines for households and individuals; or all the aforementioned and must also demonstrate that the trip cannot be funded or performed by themselves or sponsored by another agency or person.

Transit Apps

ART’s mobile app, RouteShout, allows riders to track the real-time location of the buses on their smartphone. Additionally, riders can view the location of the bus on the ART website to see the location.

ART’s microtransit service also has a mobile app option for riders to book a ride on-demand, schedule a ride in advance, and track the vehicle location.

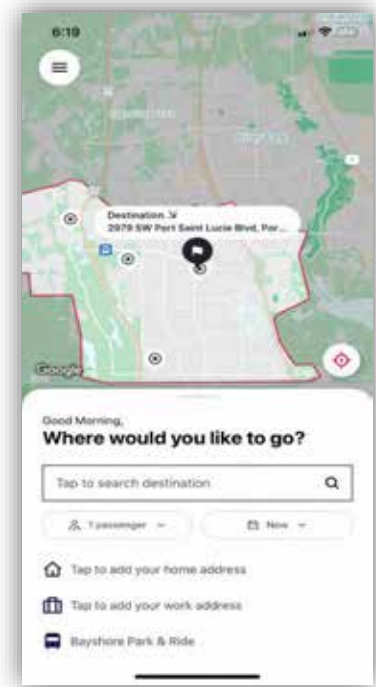

Transit Service Characteristics and Trends

Ridership Trends

A review of ART’s systemwide ridership trends from 2015 to 2024 is shown in Figure 3-1. In September of 2017, ART, announced the service would be fare-free and experienced a rapid increase in ridership until the COVID-19 pandemic. According to the Congressional Research Service, nationwide transit ridership fell by approximately 50% of pre-pandemic levels in 2020 and 2021. However, ART fared better than systems nationally and regionally, with ridership staying at approximately 62% of pre-pandemic ridership in 2021. Since 2021, ART ridership has increased, with a notable increase from 2022 to 2023 (24%).

Figure 3-1: ART Ridership | 2015-2024

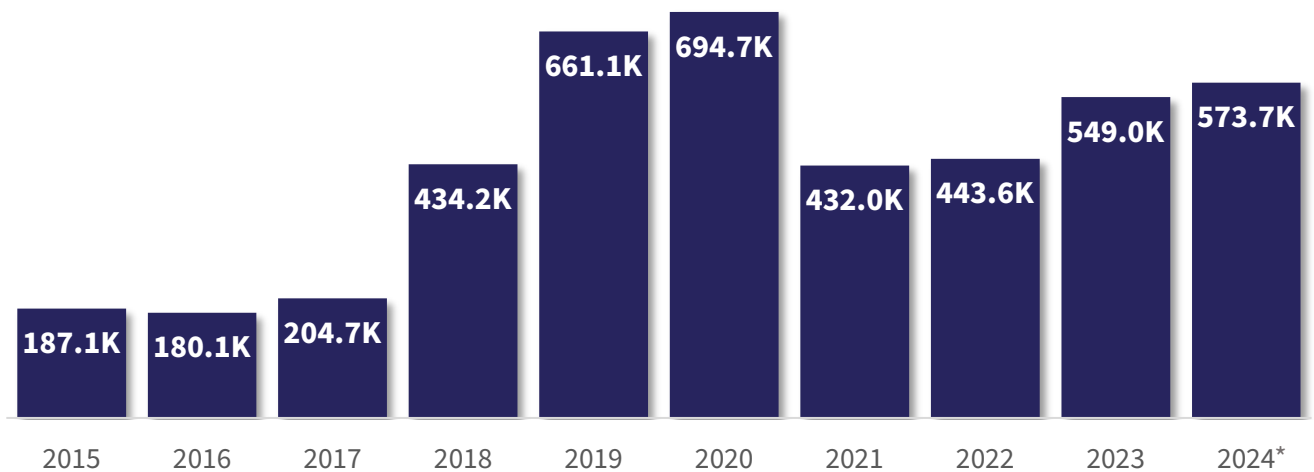

Source: NTD

*2024 annual ridership was projected based on seven months of actual data.

Monthly ridership trends also were reviewed to understand how annual ridership is affected by month of service. The average monthly ridership for FY 2022 is 36,800 passengers. August 2022 experienced the highest monthly ridership with over 45,000 passengers, or 10% of FY 2022 total.

Figure 3-2: ART Ridership / Monthly / FY 2022

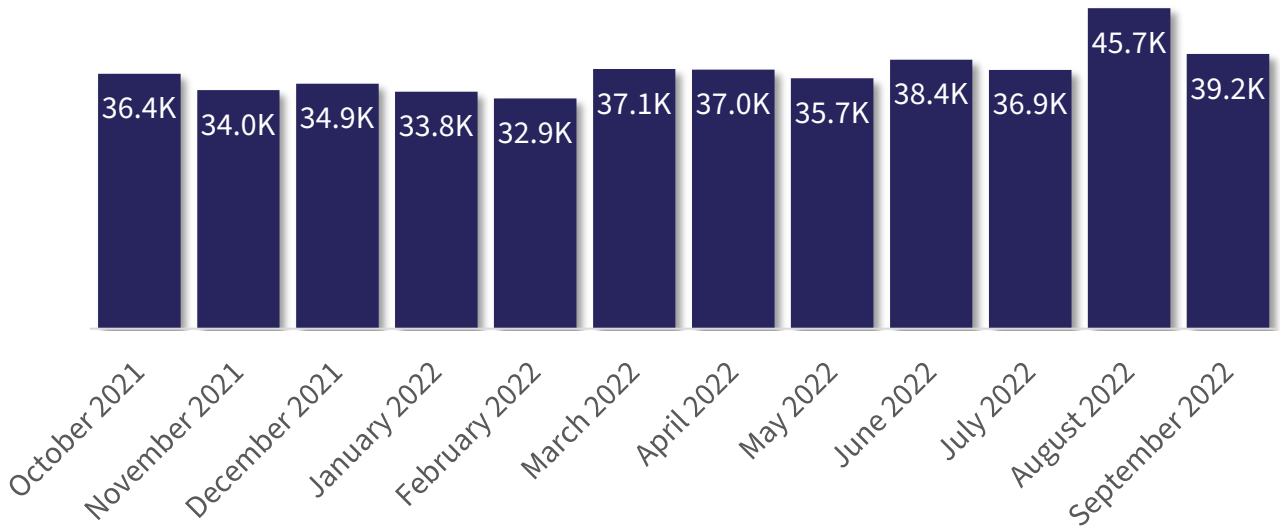

Source: ART



Productivity by Route

An additional assessment was conducted to examine productivity using ridership per revenue hour by route in FY 2022. The average ridership per revenue hour for the ART system is 12 passengers per revenue hour. The most productive route is Route 1 with over 23.2 passengers per revenue hour followed by Route 3 with 21 passengers per revenue hour and Route 2 with 16.3 passengers per revenue hour. Routes 1, 2, and 3 have above average productivity. Route 1 is a regional route that connects to the Treasure Coast Mall via US 1 while Routes 2 and 3 primarily serve the Fort Pierce area.

The least productive routes include Routes 6 and 8 with 5.7 and 3.2 passengers per revenue hour, respectively. Route 8 began operation as the pandemic began in March 2020, which may explain its lower ridership.

Figure 3-3: ART Ridership per Hour by Route | FY 2022

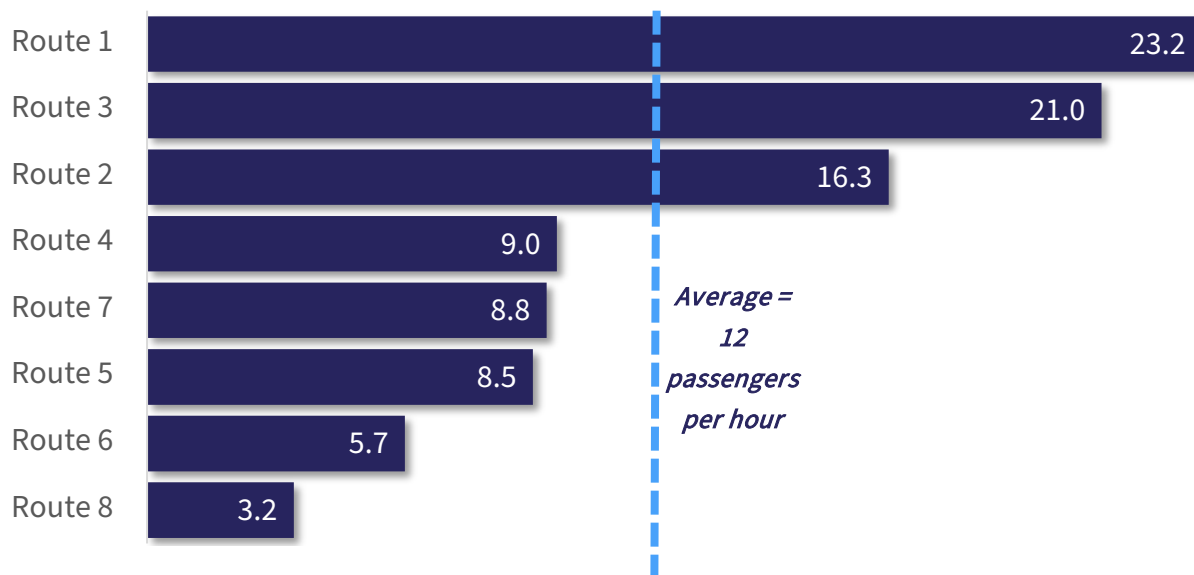

Source: ART

Existing Transit Facilities

ART maintains several passenger facilities throughout the county to accommodate fixed-route bus and microtransit riders.

Intermodal Centers

There are currently two intermodal centers that serve as major connection points for ART routes, located in Fort Pierce and Port St. Lucie. All routes in the respective areas converge to allow riders to transfer and access other ART services.

Fort Pierce Intermodal Center

ART's north transfer hub is the Fort Pierce Intermodal Center located at 434 N 8th St near downtown Fort Pierce. The terminal allows for transfers between four routes in the Fort Pierce area and Route 8 that provides a direct connection Fort Pierce to Port St. Lucie. It has an extra-large shelter, benches, bathrooms, bicycle racks, trash cans, and two park-and-ride spots.

Port St Lucie Intermodal Center

The Port St Lucie Intermodal Center is in Port St. Lucie at 395 SE Deacon Avenue. It currently provides connections for three routes and also connects to Route 8. The intermodal center has a large shelter, benches, picnic tables, trash cans, parking, and bicycle racks. There are plans to expand and improve this facility to better serve riders and the community.





Source: FDOT

Park-and-Ride Facilities

There are six park-and-ride facilities utilized by ART throughout St. Lucie County:

- Fort Pierce Intermodal Facility - 434 North 8th Street Fort Pierce, FL 34950
- Saint Lucie County Administration Complex - 2300 Virginia Avenue Fort Pierce, FL 34982
- Council on Aging Park & Ride - 2501 SW Bayshore Boulevard Port Saint Lucie, FL 34952
- Port St Lucie Intermodal Transit Facility - 395 SE Deacon Ave, Port St. Lucie, FL 34984
- The Bayshore Park & Ride - 1918 SW Bayshore Boulevard, Port St. Lucie, FL 34952
- Gatlin Boulevard Park & Ride - 2198 SW Gatlin Boulevard, Port St. Lucie, FL 34953

In September 2021, the Gatlin Boulevard Park & Ride (also called Jobs Express park-and-ride) opened with amenities such as bus bay, electric car charging, and 162 free parking spaces for ART riders and commuters.



Source: ART

Future Administration and Maintenance Facility

ART’s administration office is currently located at 2300 Virginia Avenue in Fort Pierce with other county departments. Due to ART’s growth, a new facility in a central location is needed to provide adequate space for transit operations, administration, vehicle parking, and other purposes. The total project cost is expected to be \$16 million (in FY 2021 dollars). Currently, ART has secured approximately \$7.25 million for the facility through FDOT, local, and Coronavirus Aid, Relief, and Economic Security (CARES) Act funding.

Vehicle Inventory

ART’s current fleet consists of 58 active vehicles, as shown in Table 3-2. All of the vehicles have at least 2 wheelchair positions and are still within their useful life, based on years according to FTA.

Table 3-2: Vehicle Inventory | 2023

Count	Model Year	Vehicle Type	Seats	Wheelchair Positions
Fixed Route Vehicles				
11	2012	Gillig 29'	26	2
2	2014	Eldorado 31'	30	2
2	2019	Gillig 40'	36	2
3	2022	Eldorado 31'	28	2
Paratransit Vehicles				
1	2009	Jewish Federation	18	2
1	2011	Gulfstream Goodwill	14	2
1	2013	Champion 23'	2	10
5	2014	Champion 27'	2	9
5	2014	Champion 31'	4	9
2	2016	Forest River 23'	2	10
1	2019	Goshen Coach 29'	2	10
1	2020	Ford Transit Van 22'	2	6
10	2020	Braun Van	1	4
6	2021	Ford Challenger 23'	2	10
7	2022	Braun Van	1	4

Source: ART

Other Transportation Providers

A review of other private and public organizations providing transportation services in St. Lucie County or regionally was compiled. A comprehensive inventory of transportation providers is included in Appendix A. These providers serve the public or specific client groups such as persons with disabilities, older adults, or people needing medical care.

In addition to collecting basic information, select private providers were contacted by email and asked to complete a survey to obtain specific information on the following:

- Type of service(s) provided.
- Restrictions of clients.
- Boundaries of service area and primary destinations.
- Hours of operations and any applicable frequency, annual ridership, and fares.
- Information on facilities, including location, type, age, number of vehicles, and equipment.

A copy of the survey instrument is included in Appendix A.

The summary below includes other transportation options available in St. Lucie County but not included in the provider inventory because of the scale or nature of their services. Instead, they are

briefly identified herein to provide a more complete picture of the various public mobility options available to St. Lucie County residents and visitors.

Freebee is an on-demand pilot service that connects neighborhoods and destinations from Fort Pierce to Hutchinson Island, funded by the Fort Pierce Redevelopment Agency (FPRA). This app-based private service uses electric vehicles to offer free door-to-door service in the designated zone. The service operates from 10:00 AM to 8:00 PM on Thursday and Sunday and from 10:00 AM to 10:00PM on Friday and Saturday.



City Tram is a circulator service in downtown Fort Pierce operating every 15 minutes on Friday from 5:00 PM to 9:00PM and Saturday from 8:00 AM to 3:00PM. This free tram service was introduced in 2019 and connects key parking facilities including Fort Pierce City Hall, Marian Square, and various parking lots/spaces along Indian River Drive and Backus Avenue.



Tradition in Motion (TIM) is a free autonomous fixed-route shuttle connecting neighborhoods, shopping centers, and restaurants in the Tradition area. It serves destinations along Community Boulevard, including Tradition Square Monday through Sunday. Future route expansion will provide service on Tradition Parkway and SW Village Parkway. Service on SW Village Parkway is expected to operate in exclusive lanes.



Uber and Lyft are Transportation Network Companies (TNC) providing app-based on-demand transportation throughout the county. Although services can be requested to and from anywhere, Uber and Lyft rides are most conveniently accessed in more urbanized areas where the driver supply and rider demand is higher.

Greyhound provides national intercity bus service. Regional Greyhound connections are made from Fort Pierce (Love’s gas station on Okeechobee Road) and Port St. Lucie (Gatlin Boulevard Park & Ride) to other areas of Florida and the US.

FlixBus is a private national bus operator offering daily service from St. Lucie County to other cities throughout the country from the Wawa gas station in Fort Pierce and the Gatlin Boulevard Park & Ride in Port St. Lucie. The service also has amenities such as reclining seats, Wi-Fi, and power outlets.

Farebox Recovery

ART services went fare-free in September 2017. Prior to the fare-free implementation, ART’s regular bus fare was \$2.00 and its farebox recovery ratio declined from 14.68% in 2015 to 11.06% in 2016. The Farebox Recovery Report (FRR) is in Appendix B.

Peer and Trend Analysis

This section includes a review of selected service performance trends for ART, using available NTD data from the last five years. A peer review analysis also was conducted to compare ART’s performance at a given point in time with other selected transit systems that have similar operating characteristics to what ART aspires to emulate. The performance indicators included in this analysis help evaluate and benchmark the effectiveness and efficiency of ART services.

The trend analysis is only one aspect of transit performance evaluation; however, when combined with the peer review analysis, the results provide a starting point for understanding ART’s performance over time when compared to other systems with similar characteristics. Each analysis is summarized in detail in the remainder of this section.

Data from the Florida Transit Information System (FTIS), a comprehensive data repository of historical validated NTD data for transit agencies in the US, were used for these analyses. As published NTD data are typically two years behind the current operating year due to the FTA’s rigorous review and validation processes, validated performance data for 2022 were not available from FTA and therefore were obtained directly from ART for use in the trend analysis.

Performance Trend Analysis

To assess how efficiently ART supplies its fixed-route and demand response services and how effectively each meets the needs of the area, the trend analysis used key performance indicators and two types of measures, as summarized below.

- General Indicators - quantity of service supply, passenger and fare revenue generation, and resource input
- Effectiveness Measures - extent to which the service is effectively provided
- Efficiency Measures - extent to which cost efficiency is achieved

The trend analysis was organized by type of measure or indicator and includes statistics, figures, and tables to illustrate ART’s performance over the past five years. The summary findings of the trend

analysis for fixed-route and demand response are presented in Tables 3-3 and 3-4, respectively. Appendix C provides a detailed graphical summary of the trend analysis.

Table 3-3: Fixed-Route Trend Analysis | 2018-2022

Indicator/ Measure	2018	2019	2020	2021	2022	% Change (2018-2022)
General Indicators						
Passenger Trips	434,198	661,097	694,675	432,019	443,629	2.2%
Service Area Population	313,506	321,128	328,297	336,584	336,584	7.4%
Service Area Size (sq. miles)	572	572	572	572	572	0.0%
Revenue Miles	521,386	543,201	648,772	552,007	522,913	0.3%
Revenue Hours	33,261	35,355	41,216	36,082	33,848	1.8%
Total Operating Expense	\$2,519,296	\$2,630,625	\$3,010,793	\$3,214,167	\$3,303,732	31.1%
Vehicles Operated in Max. Service	9	11	13	13	13	44.4%
Effectiveness Measures						
Revenue Miles per Revenue Hour	15.68	15.36	15.74	15.30	15.45	-1.4%
Passenger Trips per Revenue Hour	13.05	18.70	16.85	11.97	13.11	0.4%
Passenger Trips per Revenue Mile	0.83	1.22	1.07	0.78	0.85	1.9%
Efficiency Measures						
Operating Expense per Capita	\$8.04	\$8.19	\$9.17	\$9.55	\$9.82	22.1%
Operating Expense per Passenger Trip	\$5.80	\$3.98	\$4.33	\$7.44	\$7.45	28.3%
Operating Expense per Revenue Mile	\$4.83	\$4.84	\$4.64	\$5.82	\$6.32	30.8%
Operating Expense per Revenue Hour	\$75.74	\$74.41	\$73.05	\$89.08	\$97.60	28.9%

Source: NTD and ART

Fixed-Route Trend Analysis Summary

- **General Indicators** – All general indicators have increased from 2018 to 2022. Like many agencies, ART had to adjust operations to meet the challenges of the COVID-19 pandemic that began in March 2020 and dramatically changed general travel behavior. According to an American Public Transportation Association (APTA) January 2021 study on the impact of COVID-19 on public transit, national ridership dropped to 65% below pre-pandemic levels during FY 2020. ART’s ridership decreased by approximately 38% from FYs 2020 to 2021, showing that the service is relied upon and a part of the fabric of the community. Furthermore, despite the pandemic, passenger trips have increased 2.2% from 2018 to 2022 and revenue miles and revenue hours increased marginally (0.3% and 1.8%, respectively), reflecting that the system still had demand for growth. Although the operating expense increased (31.1%), the vehicles operated in maximum service (44.4%) grew at an accelerated rate suggesting ART expanded service at a faster rate than operating expenses increased.
- **Effectiveness Measures** – Despite regional and national transit industry trends, both passenger trips per revenue hour (0.4%) and passenger trips per revenue mile (1.9%) increased. This suggests that more ART riders are taking advantage of the increased service and taking longer trips.
- **Efficiency Measures** –The impact of the increased operating costs is evident in the decline of the efficiency measures. The operating expense per passenger trip (28.3%), operating expense per revenue mile (30.8%), and operating expense per revenue hour (28.9%) each increased, indicating some decline in overall cost efficiency over the past five years.



Table 3-4: Demand-Response Trend Analysis | 2018-2022

Indicator/ Measure	2018	2019	2020	2021	2022	% Change (2018–2022)
General Indicators						
Passenger Trips	102,979	90,596	68,212	59,456	103,793	0.8%
Service Area Population	313,506	321,128	328,297	336,584	336,584	7.4%
Service Area Size (sq. miles)	572	572	572	572	572	0.0%
Revenue Miles	546,048	473,184	384,346	474,274	763,597	39.8%
Revenue Hours	35,772	31,444	27,043	28,685	55,114	54.1%
Total Operating Expense	\$3,291,892	\$3,208,964	\$3,100,927	\$4,668,493	\$4,977,130	51.2%
Vehicles Operated in Max. Service	24	24	24	16	31	29.2%
Effectiveness Measures						
Revenue Miles per Revenue Hour	15.26	15.05	14.21	16.53	13.85	-9.2%
Passenger Trips per Revenue Hour	2.88	2.88	2.52	2.07	1.88	-34.6%
Passenger Trips per Revenue Mile	0.19	0.19	0.18	0.13	0.14	-27.9%
Efficiency Measures						
Operating Expense per Capita	\$10.50	\$9.99	\$9.45	\$13.87	\$14.79	40.8%
Operating Expense per Passenger Trip	\$31.97	\$35.42	\$45.46	\$78.52	\$47.95	50.0%
Operating Expense per Revenue Mile	\$6.03	\$6.78	\$8.07	\$9.84	\$6.52	8.1%
Operating Expense per Revenue Hour	\$92.02	\$102.05	\$114.67	\$162.75	\$90.31	-1.9%

Source: NTD and ART

Demand-Response Trend Analysis Summary

- General Indicators – All general indicator metrics have increased. The total operating expense (51.2%) increased parallel with the increase in revenue hours (54.1%), suggesting that the increase in expense is due to the increased supply of service. This is further supported by the annual revenue miles (39.8%) and the number of vehicles operated in maximum service (29.2%) also increasing. Although overall service supply increased, the number of passenger trips only increased marginally, 0.8%, suggesting ART could more efficiently supply these additional trips. While cost increases are not desirable, they are somewhat inevitable due to the impact of market and major inflationary factors due to the pandemic and other factors beyond the control of the transit agency.

- Effectiveness Measures – All effectiveness measures decreased over the five-year period. The passenger trips per revenue hour declined faster than the passenger trips per revenue mile suggesting that there was more use per mile and shorter trips.
- Efficiency Measures – Operating expense per passenger trip (50.0%) and operating expense per revenue mile (8.1%) have increased indicating some declines in overall cost efficiency. The operating expense per revenue hour (-1.9%) declined marginally suggesting that ART expanded service efficiently.

Agency Peer Review Analysis

A peer system review was conducted to assess how ART’s performance compares to selected transit agencies. Although validated 2021 NTD data are available in FTIS, this analysis uses 2019 data so as to not reflect the wide ranging impacts to transit agencies due to the pandemic.

This analysis uses the same general performance indicators and efficiency and effectiveness measures to compare ART’s fixed-route performance characteristics to a select group of transit agency peers. The peer selection process is described first, followed by the summary results of the peer review analyses.

Peer System Selection Methodology

The fixed-route and demand response peer system selection was conducted using 2019 NTD data available in FTIS. The agency data were then compared with 2019 data in FTIS for ART (formerly Treasure Coast Connector). The pool of possible peers was assessed and subsequently scored using the following method:

Step 1 | Geographic Elimination First, the field of peers was narrowed by geographic location to agencies in the southeast US, including Alabama, Arkansas, Florida, Georgia, Louisiana, Mississippi, North Carolina, South Carolina, Tennessee, and Texas. These states are assumed to have similar operating environments to ART. In addition, special consideration was given to transit properties operating geographically closer to ART.

Step 2 | Mode Review Using the subset of southeast agencies determined in Step 1, the pool was further narrowed by mode to agencies providing fixed route or motorbus and/or demand response services (classified as “MB” and “DR” modes, respectively in the NTD). The selected agencies were separated by mode to ensure an appropriate peer set for the respective mode.

Step 3 | NTD Analysis Using 2019 NTD data, the pool of potential peers was scored through an objective assessment of eight standard key variables:

- Average speed (revenue miles/revenue hours)
- Passenger trips
- Revenue miles
- Service area population
- Service area population density

- Total operating expense
- Vehicles operated in maximum service (VOMS)
- Revenue hours

Maintaining separation by mode type, each agency was scored on each variable. The scores are based on an agency’s similarity to ART’s value for that variable for that year. An agency received 1.0 point when its performance value for a variable was within one standard deviation of ART’s performance value and 0.5 points for each variable that fell within two standard deviations of ART’s performance value. If an agency’s value fell outside of two standard deviations of ART’s performance value, no points were given for that variable.

After each agency was scored on each variable, the scores were totaled and the agencies were ranked based on the total amount of points received. Only the top 25 agencies in each mode from each year moved forward into Step 4.

Step 4 | Peer Selection Maintaining the agency lists by mode, the final list of peers was determined through further qualitative scoring. Any agency ART had identified as a peer through a past peer selection process or is geographically similar was given additional consideration. The final set of peer agencies was then selected.

Peer Review Analysis Summary | Fixed-Route

Table 3-5 presents the final set of peers selected using the methodology summarized above. The results of the peer review analysis of ART’s fixed-route bus service are presented in Table 3-6 in terms of its deviation above or below the peer group mean and a general assessment of the result.

Table 3-5: Fixed-Route Peers

Agency Name	Location
Augusta Richmond County Transit Department (Augusta Transit)	August, Georgia
Jackson Transit Authority (JTA)	Jackson, Tennessee
Indian River County (GoLine)	Vero Beach, FL
City of Ocala, Florida (SunTran)	Ocala, FL
Lake County Board of County Commissioners (LakeXPress)	Tavares, FL
The Marty	Stuart, FL

Table 3-6: Fixed-Route Peer Analysis

Indicator/Measure	ART % from Peer Mean	Assessment
General Indicators		
Passenger Trips	27.9%	Good
Revenue Miles	-7.1%	Can Improve
Revenue Hours	-2.8%	Can Improve
Total Operating Expense	-2.9%	Good
Vehicles Operated in Maximum Service	10.0%	Good
Effectiveness Measures		
Passenger Trips per Revenue Mile	51.4%	Good
Passenger Trips per Revenue Hour	46.8%	Good
Efficiency Measures		
Operating Expense per Passenger Trip	-47.0%	Good
Operating Expense per Revenue Mile	1.7%	Can Improve
Operating Expense per Revenue Hour	-0.6%	Good

- General Performance Indicators – ART provides a similar level of service to that of its peers, but has a higher number of trips. This indicates that ART has been capturing a greater level of demand than its peers. Scoring below the peer mean in revenue miles (-7.1%) and revenue hours (-2.8%) while scoring above the peer mean in passenger trips at a high variance (27.9%) suggests that ART is achieving better service productivity than its peers.
- Effectiveness Measures – ART has been effective in matching services to its current level of demand compared to its peers, achieving above average numbers of passenger trips per revenue miles (51.4%) and hours (46.8%). This also suggests that ART is achieving more service consumption than resources expended compared to its peers.
- Efficiency Measures – ART scored below the peer mean in most of the cost efficiency measures. It scored below the peer mean for operating expense per passenger trip (-47.0%), suggesting that ART is more efficient at controlling its costs as compared to its peers. ART scored marginally above the peer mean for operating expense per revenue mile, which may suggest that its peers are supplying longer trips more efficiently.

Peer Review Analysis Summary / Demand-Response

Table 3-7 presents the final set of demand-response peers. The results of the peer review analysis of ART’s demand-response bus service are presented in Table 3-8.

Table 3-7: Demand-Response Peers

Agency Name	Location
Charleston Area Regional Transportation Authority (CARTS)	Charleston, South Carolina
Transit Authority of Northern Kentucky (TANK)	Fort Wright, Kentucky
Northwest Alabama Council of Local Governments (NACOLG)	Muscle Shoals, Alabama
Manatee County Area Transit (MCAT)	Bradenton, Florida
Cabarrus County Transportation Services (CCTS)	Kannapolis, North Carolina
Capital Area Transit System (CATS)	Baton Rouge, Louisiana

Table 3-8: Demand-Response Peer Analysis

Indicator/Measure	ART % from Peer Mean	Assessment
General Indicators		
Passenger Trips	3.2%	Good
Revenue Miles	-28.9%	Can Improve
Revenue Hours	-29.0%	Can Improve
Total Operating Expense	11.3%	Can Improve
Vehicles Operated in Maximum Service	-11.7%	Good
Effectiveness Measures		
Passenger Trips per Revenue Mile	36.7%	Good
Passenger Trips per Revenue Hour	39.5%	Good
Efficiency Measures		
Operating Expense per Passenger Trip	8.7%	Can Improve
Operating Expense per Revenue Mile	56.7%	Can Improve
Operating Expense per Revenue Hour	61.0%	Can Improve

- General Performance Indicators – ART has performed well compared to its peers in most of the general performance indicators. Scoring above the peer mean in passenger trips (3.2%) and below the peer mean in revenue hours (-29.0%) suggests that ART is achieving better demand response service productivity than its peers. Furthermore, ART manages to operate more efficiently with fewer vehicles than the peer average.
- Effectiveness Measures – ART scored above the peer mean in passenger trips per revenue hour (39.5%) and passenger trips per revenue mile (36.7%). Performing better indicates that ART is achieving more from its resources expended than its peers.
- Efficiency Measures –Although ART has generally performed well when compared against its peers, its deviance from the operating expenses peer mean surpasses the deviance from passenger trips. This somewhat justifiable because of its much higher positive variance from the peer mean for passenger trips per revenue hour (39.5%). This suggests that, although ART is spending more per revenue hour, revenue mile, or passenger trip than its peers, it is doing much more (i.e., serving more passengers) with each unit of this service resource allocated, compared to its peers.



Section 4. Public Involvement Summary

Public involvement input provides critical information for developing the 10-year transit needs in the community. With various avenues to gather public input, it helps to obtain information to ascertain community perceptions on and expectations for transit services locally and regionally. This section summarizes the public involvement process and related activities conducted for the *Reimagine Transit* TDP. Key findings from each of the completed events also are analyzed and discussed.

Prior to initiating any activities, ART, in partnership with the St. Lucie Transportation Planning Organization (TPO), prepared a Public Involvement Plan (PIP) to guide the public involvement process and activities to be undertaken during the TDP. The PIP was submitted for review and approval by FDOT District Four prior to implementing the TDP outreach activities. As shown in Appendix D, the PIP includes a wide range of activities to provide numerous opportunities for involvement by the public and key stakeholders representing local and regional public or private agencies and organizations.

Public Involvement Techniques

To engage a full range of community stakeholders and facilitate active participation during the *Reimagine Transit* TDP development process, activities categorized as direct or indirect were used.

Indirect involvement techniques use materials or methods to inform the public and stakeholders about the project, including branding, social media outreach, website content, emails, and other materials such as fact sheets, flyers, display boards, and media releases.

Direct involvement techniques directly engage the public and stakeholders “hands-on” in forums such as public workshops, stakeholder interviews, discussion groups, rider and non-riders surveys (in person or online), and presentations to elected officials.

Summary of *Reimagine Transit* Public Involvement Activities

Several direct and indirect public involvement activities were used to ensure adequate opportunities for ART’s riders, community stakeholders, and the public to actively participate in the TDP development process. Table 4-1 summarizes the public involvement activities conducted thus far and the scale of engagement to date.

The TDP public involvement is an ongoing effort and only Phase I has been completed to date. Findings summarized in the remainder of this section do not include upcoming public workshops, surveys, etc., planned for Phase II. Those will be summarized in the subsequent reports prepared for the TDP.

Table 4-1: TDP Public Involvement Summary

Outreach Activity	Date	Engaged
Project Review Meetings	July 2023– March 2024	7
Stakeholder Interviews	August – October 2023	25
Bus Operator Interviews & Survey	August 2023	11
Discussion Group Workshops		
Bus Rider	August 23, 2023	12
Social Services	September 7, 2023	9
Business and Education	September 7, 2023	6
Phase I Public Workshops		
Port St. Lucie	August 22, 2023	21
Fort Pierce	August 23, 2023	6
Phase II Public Workshops		
Port St. Lucie	February 13, 2024	55
Fort Pierce	February 13, 2024	22
Surveys		
Transit Needs Survey	August – November 2023	136
Transit Priorities Survey	February – March 2024	170
Other Outreach		
Email	July 2023– May 2024	96
Web/Social Media	August 2023– March 2024	404
TPO Committees & grassroots efforts	July 2023– May 2024	34
Total		1,014



Project Review Committee Meetings

One goal of the *Reimagine Transit* TDP is to ensure that it is developed with necessary oversight, quality control, and transparency. To support this, a Project Review Committee (PRC) was established to guide the TDP process and to facilitate project coordination among the various members.

The PRC was established based on guidance from ART and the St. Lucie TPO and included representatives/staff from ART, the TPO, and the Regional Workforce Board. The following is a summary of the key coordination activities.

- Project Kick-off/PRC Meeting #1 – In July 2023, a virtual meeting was held with the PRC to discuss the TDP goals and objectives, review project tasks and deliverables, discuss the planned public involvement strategies, examine coordination of the TDP with other local and regional plans, and review the project schedule.
- PRC Meeting #2 – On November 2, 2023, the PRC met virtually to discuss the completed public outreach events, expectations for upcoming public outreach events, and development of the alternatives for the 10-Year plan.
- PRC Meeting #3 – On December 19, 2023, the PRC met virtually and reviewed the draft 10-Year service and capital needs. Key findings from data analyses and latest public outreach efforts were presented followed by a discussion about the 10-Year TDP needs.
- PRC Meeting #4 – On May 1, 2024, the PRC met virtually and reviewed the 10-Year plan. The recommended service and capital improvements along with the latest public outreach efforts were presented followed by a discussion.
- Additional Virtual Meetings – Additional phone conversations/meetings were conducted to discuss applicable items or obtain direction from the staff.

TDP Branding

To uniquely identify it from other local and regional planning efforts and to increase awareness of this process, the TDP was branded as “*Reimagine Transit*” based on input from the PRC. While branding can make TDP public participation more engaging and user-friendly during the development process, its continued use post-adoption provides a consistent theme and message when promoting the TDP in the years to come.



Stakeholder Interviews

Stakeholder interviews are one-on-one meetings to gather input from policy, agency, or community leaders regarding the future for ART and transit needs in the community. This input enhances the understanding of local conditions for transit as assessed through the perceptions and attitudes of stakeholders representing members of the broader community. For the *Reimagine Transit* TDP, 25 stakeholders were interviewed from August to December 2023 (Table 4-2).

Interview Methodology and Technique

A uniform list of questions and discussion topics was developed and provided to each stakeholder ahead of the interview. The script for the interviews is included in Appendix D. The input received during these interviews was reviewed and major themes identified and summarized. Overall, interviewees indicated the need for more transit options in St. Lucie County, including increased access to key employment, education, and commercial hubs and expanding transit services for everyone. A more detailed summary is provided following the table.

Table 4-2: Stakeholder Information

Stakeholder	Organization	Title
Robert Driscoll	Council on Aging	Transit Director
Robert Dadiomoff	Veteran's Community	Representative
Jack Kelly	St. Lucie Public Schools	Board Member
George Landry	St. Lucie County BOCC	County Admin.
Mayte Santamaria	St. Lucie County BOCC	Dept. County Admin.
Peter Tesch	Economic Dev. Council	President
Cathy Townsend	St. Lucie County BOCC	Commissioner
Chris Dzadovsky	St. Lucie County BOCC	Commissioner
Larry Leet	St. Lucie County BOCC	Commissioner
Linda Bartz	St. Lucie County BOCC	Commissioner
Jamie Fowler	St. Lucie County BOCC	Commissioner
Shannon Martin	City of Port St. Lucie	Mayor
Jolien Caraballo	City of Port St. Lucie	Vice Mayor
Stephanie Morgan	City of Port St. Lucie	Council Member
David Pickett	City of Port St. Lucie	Council Member
Anthony Bonna	City of Port St. Lucie	Council Member
Linda Hudson	City of Fort Pierce	Mayor
Arnold Gaines	City of Fort Pierce	Commissioner
Curtis Johnson Jr.	City of Fort Pierce	Commissioner
Jeremiah Johnson	City of Fort Pierce	Commissioner
Michael Broderick	City of Fort Pierce	Commissioner
Nicholas Mimms	City of Fort Pierce	City Manager
Jesus Merejo	City of Port St. Lucie	City Manager
Dr. Timothy Moore	Indian River State College	President
William G. Theiss	Town of St. Lucie Village	Mayor

Transit Today (Input on Existing Services)

The section includes input on how transit is currently doing and how it is perceived in the community. In general, stakeholders responded positively to the services currently provided by ART and endorsed its role to provide mobility options in St. Lucie County.

ART is a valued and needed service in St. Lucie County.

Awareness of ART Services – Stakeholders agreed that transit is a necessary service in St. Lucie County and ART is doing a great job of supplying the service. However, it was also mentioned that, although most people are familiar with ART, there is a lack of awareness of what specific services ART provides, its service area, and other operating details.

On improving awareness, most agreed there needed to be multiple marketing strategies to attract more riders.

Perception of ART – As previously mentioned, stakeholders had positive comments about ART’s role in the community. Most stakeholders felt that the community viewed ART as a service for those without access to a car or who are not able to drive. Many stakeholders perceive the service as being for those who do not have a choice to ride. Other stakeholders added that there is a worry about convenience and most agreed that it will take time to reduce single-occupant vehicle trips as residents are attached to their vehicles.

Access to Transit Information – Most respondents agreed that the information about the service is readily available and those who are interested would be able to find it. Although the information is available in many key locations, stakeholders mentioned that it would be helpful to have bus system materials in more places, such as popular shopping centers, doctors offices, or government offices. Additionally, there were concerns expressed that those without access to smartphones or the internet, such as older adults, would not know how to access the system and there should be traditional information pamphlets available. Some stakeholders also suggested including ART information in local publications and circulars from social service agencies. Overall, most agreed there needed to be multiple marketing strategies to attract more riders.

Responsiveness of ART – Most stakeholders commented positively on the reputation that ART has regarding its responsiveness to community’s transit needs over the years. Stakeholders felt that ART has done an outstanding job responding to any identified needs in the community.

Where Do We Want to Go? (How should the future ART network look?)

Expanded Service Area – Stakeholders identified expanding the current service area to help increase connectivity to jobs as a top priority. Stakeholders identified a desire for transit services connections Indian River State College (IRSC) campuses, key job centers, and to the airport in the future to meet community needs, diversify the customer base, and increase ridership. Some stakeholders mentioned Hutchinson Island as an area of St. Lucie County that is not currently served but should be considered.

We need additional connections to jobs in St. Lucie County.

More On-Demand Transit – Implementing additional app-based microtransit services was also discussed. Stakeholders agreed that the smaller vehicles and point-to-point service was popular and they would like to see more of this service type, specifically targeting areas north of Fort Pierce, St. Lucie West, and Port St. Lucie. Some stakeholders mentioned that microtransit services are better for shorter trips than fixed-route.

Expanded Service Hours - There was consensus on the need for the service span to be extended, both earlier and later in the day. The stakeholders expressed their appreciation for the span of services currently provided and would like to see extended service hours so that workers with non-traditional/additional shifts would have reliable transportation to or from work. Some stakeholders also indicated a need for service to operate seven days a week.

Enhanced Frequencies – Stakeholders agreed that, to increase ridership and usage of ART, increasing the frequency of service is needed on US 1 and other key corridors. This would help attract choice riders by making the service more convenient and also increase quick connections to job centers.

Regional Transit – Stakeholders had varying views on regional transit connections. Several stakeholders commented on need due to increased inter-county growth and development patterns, but most wanted to keep the workforce connections within St. Lucie County. Some stakeholders felt the connections to Vero Beach and Stuart were necessary while a few other indicated the need for connections to West Palm Beach and Okeechobee.

Improved Marketing and Education – All stakeholders commented on the need to expand marketing the service and educating the public on the many benefits of using transit. It was also recommended that ART should increase outreach to the community and educate residents on the services currently available.

Improved Infrastructure – Stakeholders commented that accessible and enhanced bus stop infrastructure like shelters and benches would be great marketing tools for ART and encourage riders by making it more comfortable to wait for the bus. Stakeholders also mentioned difficulty reaching bus stops where there are no sidewalks, especially along busy roads.

Rail Connection - Stakeholders also weighed in on and expressed excitement for a potential passenger rail connection in Fort Pierce. Since visitors arriving by passenger rail may not have a car, stakeholders felt that the County needs to anticipate connecting passenger rail passengers to and from their destinations. Stakeholders discussed that a local passenger rail station would help increase regional connectivity and bolster the local economy.

How Do We Get There? (What improvements are necessary to achieve that network?)

More Service and Service Span Expansion – All stakeholders agreed that more transit service in St. Lucie County is needed and there is a mismatch with the growing area and limited-service coverage and spans. Additionally, the need for more on-demand service was repeatedly mentioned. It was emphasized that expanding service span is more important than adding new routes or service types.

More Frequent Service – Stakeholders identified improving frequency to help increase ridership as an ART key need for the next 10 years. Not only would this attract more discretionary riders, higher frequencies, at least on popular routes, would also improve the service for current users.

Direct Connections – The discussion regarding more direct connections with possibly the use of smaller vehicles was discussed by some stakeholders. They felt there are opportunities to tailor services locally and residents may use the service more if it directly connects to nearby destinations like shopping centers, health/recreation facilities, and education centers, such as IRSC. Stakeholders agreed that current on-demand microtransit services should be expanded as there is existing and projected demand.

Enhanced and Safe Access to Bus Stops – Stakeholders frequently cited the need for better accessibility to existing bus stops. Some felt that it is a serious safety issue to walk along busy roadways without sidewalks or to wait in an area with low visibility to oncoming traffic.

Improved Amenities – Stakeholders commented on bus shelters and the need to provide protection from heavy rain, thunder/lightning, and sun in Florida. Stakeholders indicated that safe, accessible, and welcoming shelters are necessary. Stakeholders agreed that the existing park-and-rides are in good locations for riders to connect to and from St. Lucie County.

New Vehicle Types – Some stakeholders said they would like to see more technology-focused capital investments, such as autonomous and electric vehicles, to attract discretionary riders who may be more environmentally-conscious. Purchasing electric vehicles also aligns with St. Lucie County’s goals to balance growth and infrastructure with natural preservation. One respondent indicated that autonomous vehicles are the future and ART should try to integrate them into the fleet as needed or when vehicles need replacements.

Other/General Comments:

- There is better awareness since ART has rebranded and staff have been actively doing community engagement.
- There is more interest and awareness in transit post-pandemic and since ART moved to a fare-free system.
- Job centers with warehouses are coming and will need transportation options for shift workers.
- Technology will continue to evolve and we must plan for it.
- Autonomous and electric vehicles will be a part of the solution to transportation issues.
- More marketing and education efforts are needed.

Bus Operator Interviews and Survey

Bus operators, as ambassadors of ART, have ongoing contact with the existing ridership base. Their ability to offer route-level and system assessments as well as rider input from their frequent interactions with riders makes their input critical for the TDP. As part of the TDP, input from ART bus operators and supervisors also was obtained to gauge their opinions on existing services, future improvements, vision for ART, safety issues, and rider remarks.

A total of 11 bus operators were engaged to obtain input. In addition to in-person discussions, a survey also was provided to ART bus operators who did not get interviewed in-person to gauge their opinions on existing services, future improvements, vision for ART, safety issues, and rider remarks.

Key input includes the following:

- Certain current segments should be reassessed to streamline before continued service
- Sometimes keeping bus schedule (staying on time) is difficult on routes on congested roadways, such as US 1
- Riders need more bus shelters/benches



Discussion Group Workshops

Another outreach activity completed for the *Reimagine Transit* TDP were discussion group workshops with small groups of stakeholders representing key focus areas for transit. Three discussion group workshops were held and served as a virtual roundtable. The participants took part in assessing existing services and determining future transit needs using questions to motivate and inspire conversation about the transit development process.

The TDP project team coordinated with the PRC to invite potential participants representing the following perspectives: current riders, social/public service agencies, and business/education. Thereafter, with the input received from the PRC members, including ART staff, potential participants were contacted by the project management team via email and phone calls to invite them to their respective discussions.

Discussion Group #1 – Bus Riders

The first workshop was held with bus riders to gauge their perceptions of current ART services and what they see as future needs. Riders were identified by ART staff and were contacted by phone and email to attend. Additionally, some were engaged for discussions at the Port St. Lucie Intermodal Center. The workshop was held on August 23, 2023, from 10:00 AM –12:00 PM.

Eleven bus riders were involved in this discussion group and related follow-up efforts to ensure that all viewpoints were accommodated. The following is a summary of the comments received at the bus rider discussion group about existing and future ART services.

Transit Today

- Awareness – Participants agreed that the public is generally aware of ART but not aware of all services available and what they entail.



- Responsiveness – Most participants agreed that ART is generally responsive to their needs and requests outside of later evening service and increased frequencies, which have not yet been implemented.

Where We Want to Go

- Frequency and Service Hours – Participants would like to see ART provide more service on existing routes by increasing frequency and span and a system that runs all week. Some participants would use ART to get to other jobs on the weekends but currently cannot due to limited or absence of weekend service.
- Expanded Service Area and New Connections – Participants overwhelmingly indicated they appreciate the current service but want it expanded to new areas. Additional services on Bayshore Boulevard and Midway Road were mentioned, as well as the desire to reach more recreational activities throughout the county.

How We Get There

- Expanded Service – A key need for most ART riders is expanding services, particularly to new destinations, and additional service hours to access service jobs, recreational activities, or shopping centers. The drop in later evening service is a key issue for many.
- More Frequent Service – In addition to participants wanting expanded service coverage and spans, participants also mentioned higher frequency service as a key need, especially along denser corridors in the county.
- Marketing and Education – Participants suggested that ART do more awareness and marketing of the services using social media as an outreach tool and to educate the public on the benefits of transit.

Discussion Group #2 – Social/Public Services Agencies

Social and public service agencies in St. Lucie County that regularly engage with current and potential ART riders were invited to the discussion group on September 7, 2023 to provide input on transit needs for their clients.

Participants from the neighboring Martin and Indian River County Transit agencies, HANDS Clinic, Family Care Council, CareerSource (regional workforce development board), United Way, and Veterans organizations contributed to the discussion. Input obtained from a guided group discussion was categorized into key themes and summarized below.

Transit Today

- Expanded Availability of Information – Although information on transit is available, new riders may not know where to find it. Participants also mentioned a fear component for new riders, especially for persons with disabilities, about their ability to use the current services so trust needs to be built.

- More Awareness Needed – Participants felt that awareness of ART’s services could be improved. Some participants mentioned that although adult residents do get information, high schoolers may not.
- Critical Need in the Community – Participants perceived ART as a critical service to the community. They mentioned how transit is vital for those with no other way to access services provided by social care and health care agencies. However, participants felt that the community at large views ART as a service used primarily by low-income, low-resource residents. One participant mentioned that there is a stereotype that the service is used by those who cannot drive or have a DUI or a suspended license, as opposed to seeing transit as a part of the culture of the community as it is in other areas.
- ART is Doing a Good Job – Participants believed that ART provides a very reliable and effective service with the resources available. Some participants communicated to them that they would like to give up their car and use ART for their travel needs. Participants believed that ART is responsive to community needs.
- Increasing Traffic Congestion – When asked about congestion, participants felt that there is traffic in St. Lucie West and on Bayshore Boulevard and transit can provide a remedy.

Where We Want to Go

- Need More Connectivity Options – Participants recommended increasing local and regional connectivity. Some participants mentioned expanding service to currently unserved areas in the county. Participants like the regional service connections to Vero Beach and Stuart, but also mentioned needing connections to Okeechobee. The participant representing transit service in Indian River County mentioned that its riders enjoy and rely on ART services.
- Need More Convenient Options – Participants stated a need to improve the frequency of routes. Participants liked the existing microtransit service but felt there was a need east of the Turnpike.
- More Marketing Campaigns – Participants recommended developing a marketing campaign to encourage ridership targeting employers and education institutions.

How Do We Get There

- Increasing Connectivity – While participants noted the importance of regional connectivity for accessing social services, the focus should be on improving connectivity within St. Lucie County.
- Service Improvements – Later service and expanding service to new destinations were highlighted as important needs.
- Improved Technology and Infrastructure – Bus stop improvements ranked high on the list, including improved shelters against sun and rain and accessible connections to stops.

- Increased Marketing and Education – Participants strongly recommended creating an education campaign on the benefits and attractiveness of ART services, including promoting the cost savings of riding transit compared to driving.

Discussion Group #3 – Business and Education

Stakeholders representing business and education sectors were invited to the third group discussion to get input from their perspective on transit in the county. The discussion group workshop was held on September 7, 2023 and included representatives from the St. Lucie County Planning and Development Department, Treasure Coast International Airport, Economic Development Council (EDC), and St. Lucie Chamber of Commerce. Key highlights from this discussion are summarized below.

Transit Today

- ART Services are Needed – Overall, participants perceive ART as a critical service for the community but it needs to be more convenient to get people to and from lifeline trips, such as education and work. Participants discussed that businesses want employees to be able to use ART to get to work. Some participants mentioned ART can help more people access educational opportunities.
- Incorporate Technological Solutions – Participants expressed an interest in technology-based, on-demand microtransit. Participants were aware that the service exists in the Port St. Lucie area and thought that it was a promising solution implemented by ART successfully.
- Perception – Participants perceive that there is support for ART but many believe it is a service for the disadvantaged. Participants believe that the biggest obstacle to public transit is public sentiment. They would like to see a campaign to change this perception to one that ART is for everyone in the community.
- Need Better Infrastructure – Participants see a need to build safer transit bus stops and this effort could be coordinated with multimodal transportation improvements including sidewalks, trails, and crosswalks.
- Traffic Congestion is a Major Issue – Participants stated congestion is an issue in particular areas, like Port St. Lucie, during peak hours. They also expressed that most residents and leaders feel congestion is worsening and are receptive to remedies from transit.

Where We Want to Go

- Outreach is Needed for Ridership Growth – Participants suggested improved communication and collaboration via multiple outlets would help increase the awareness around ART. They would like to see a more coordinated effort to get information out by using popular venues like IRSC. Some felt that social media may be a tool to use but may not be as effective to spreading the word.
- Increased Service Options and Supply for Growth – Other participants expressed a need to enhance mobility options to battle traffic congestion. They expressed that more transit

options, particularly serving Kings Highway and St. Lucie Boulevard, may help reduce congestion. Other participants agreed that transit connections to educational centers, such as IRSC, was a gap that needed to be filled.

How Do We Get There

- Overall, participants felt that a range of improvements, including traditional bus and on-demand options, are needed for transit to be more attractive to the community.
- Additional Marketing – Participants repeatedly agreed that ART’s top priority should be marketing. With additional growth coming, outreach should be a priority, not only to the workers, students, and visitors, but also to those who are considered Limited English Proficient (LEP) or are other transportation groups.
- Regional Connectivity – Participants felt that regional connectivity is needed for educational opportunities. They thought there may be a need for additional or enhanced regional connections to Martin County.
- New Services and Service Enhancements – Participants mentioned using quick routes to reach north to south county, while connecting key cities, job centers, airport (at least later in the 10-year period), and IRSC campuses. Additionally, frequency of transit should be increased in Fort Pierce, where it is most heavily used at this time.



Phase I Outreach

Open House Public Workshops

As part of the TDP public involvement process to determine how St. Lucie County should improve its service and to identify specific and additional service needs, two open house public workshops were held in Port St. Lucie and Fort Pierce in August 2023. The focus was understand participants' views about ART and what St. Lucie County can do going forward to make transit a more viable travel alternative. In addition to the public, the PRC members were invited to attend.

Workshop #1 – Port St. Lucie

The first public workshop was held at the Morningside Library in Port St. Lucie from 2:00–4:00 pm on August 22, 2023. This workshop was attended by 21 participants.

The following is a summary of the comments received at the Port St. Lucie workshop on existing and future transit services in St. Lucie County.

- Expanded Service Area - All participants agreed that there is an additional need for transit services in St. Lucie County and supported fixed-route transit and additional on-demand services.
- Increased Frequency - Participants indicated a desire for more frequent service on existing routes. Most participants agreed that more popular routes need service at least every 30 minutes.

In addition to various display boards and feedback stations, an interactive exercise also was included as part of the event. When participants were asked by that activity to identify if they would rather have additional traditional bus service or microtransit, most chose microtransit service. Additionally, most participants preferred an expanded service area even with low frequency more than high-frequency service with a limited-service area footprint.



Workshop #2 – Fort Pierce

A second workshop was held on August 23, 2023, from 2:00–4:00pm at the Zora Neale Hurston Library in Fort Pierce. Similar to the previous workshop, this event gathered information on the insights the public shared about transit issues throughout the county, but especially in that area. This workshop was attended by 6 participants.

The following is a summary of the comments received during the Fort Pierce workshop regarding the existing and future transit services in St. Lucie County:

- Expanded Service Area and Weekend Service - As in the previous workshop, almost all participants agreed there was need for expanded services within the county that included a mix of fixed-route and on-demand service. Most attendees indicated more services in the west were needed, as the area is growing in employment and some new residential developments. Additionally, participants agreed that there was a need for weekend service.
- Increased Frequency - Participants expressed the need to connect to existing destinations more often. Participants said that service was needed more than every 60 minutes to connect to lifeline trips.

Like the first workshop, as part of the interactive activity, participants identified they would rather have microtransit more than additional traditional bus service. Additionally, most participants preferred an expanded service area with low frequency more than high-frequency service with a limited-service area.

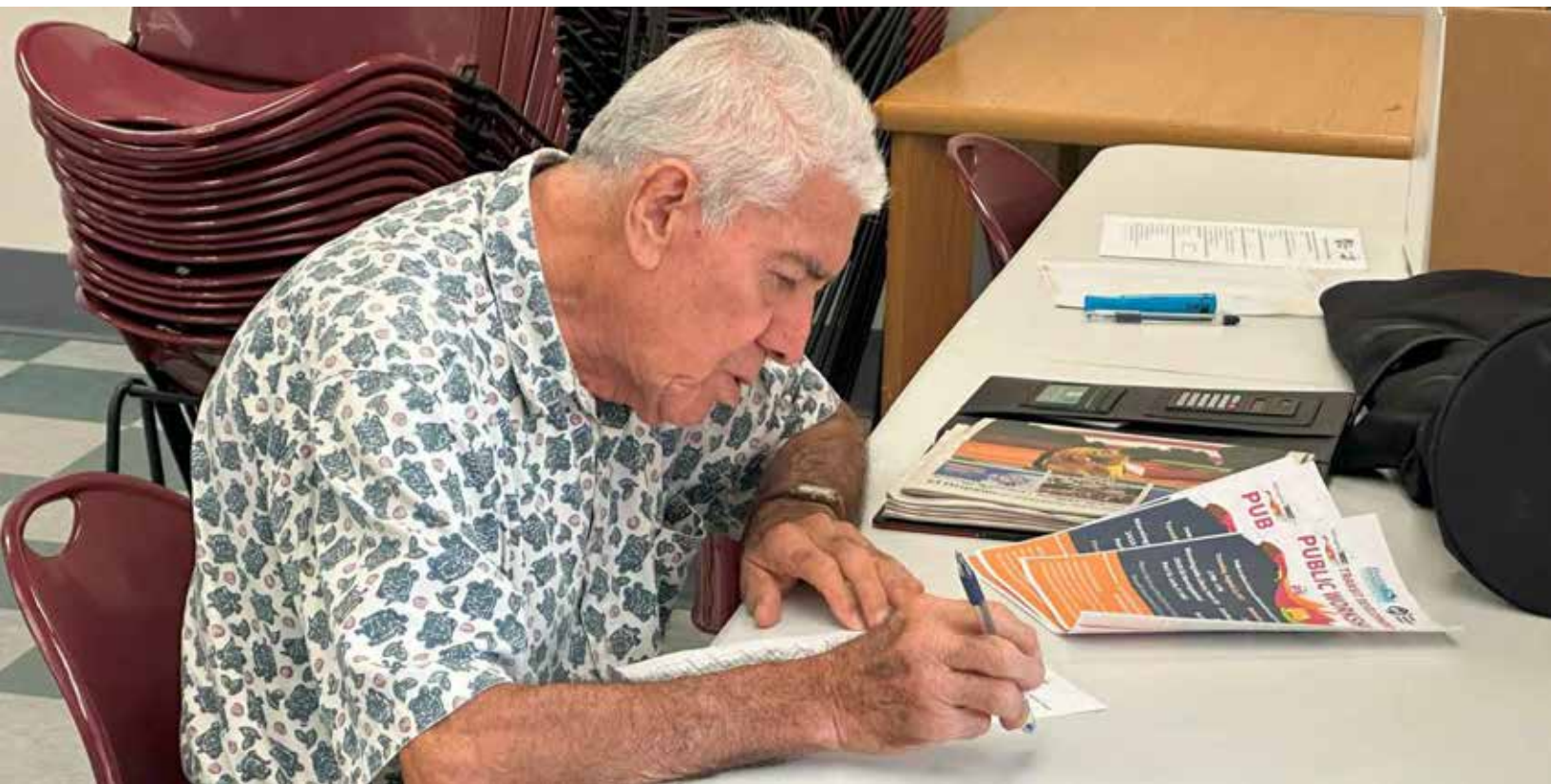

Transit Needs Survey

An online public input survey was initiated in August 2023 and made available via social media, email, the ART website, as well as electronic tablets at workshops. An awareness campaign on the survey was conducted using online platforms and through the various TDP stakeholders.

Questions were asked about current services, willingness to use public transit, and the community’s transit needs. The survey was also designed to gauge public awareness of transit in St. Lucie County and to gather socio-demographic information about survey respondents. A total of 136 surveys were completed and the results summarized below.

Survey respondents were asked if they or a member of their household have used ART. The majority responded they have used ART (55%). Figure 4-1 shows 36% had not and 10% did not know there is public transit in St. Lucie County.

Figure 4-1: Have you or a member of your household used St. Lucie County’s public transportation service, Area Regional Transit (ART)?

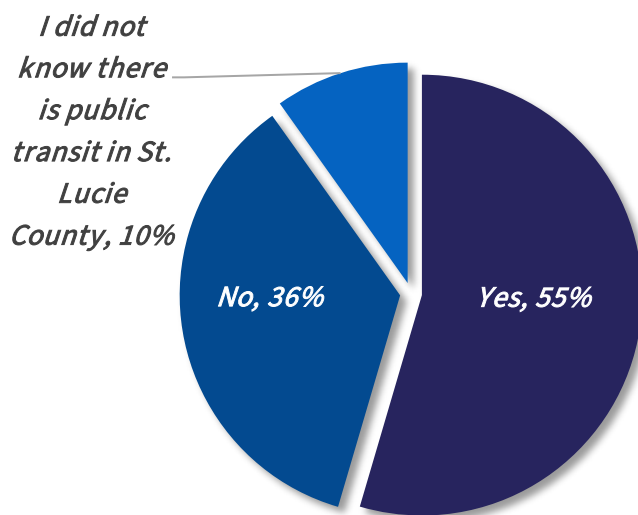

Although only 55% of respondents indicated they have used ART previously, 79% said that it must be provided (Figure 4-2). Some respondents thought that it might be useful (16%), and only 2% said it is not needed.

Figure 4-2: How important is providing bus transit services in St. Lucie County?

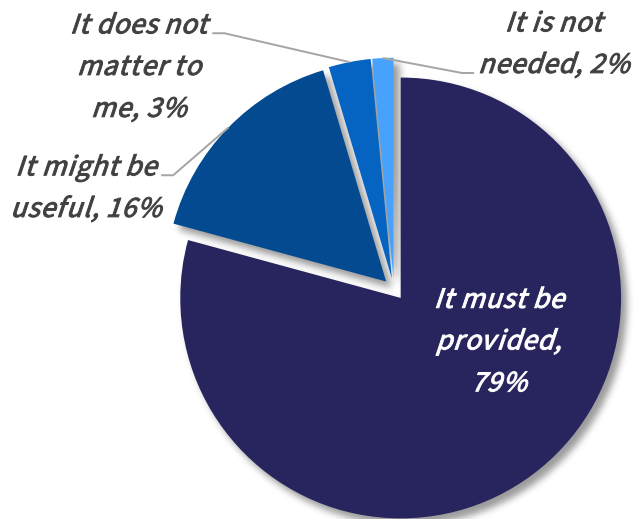

Respondents were asked if there is a need for additional or improved transit services in St. Lucie County. Most (91%) agreed that there is. Less than 10% of participants, as shown in Figure 4-3, said that there is not a need.

Figure 4-3: Do you think there is a need for additional/improved transit services in St. Lucie County?

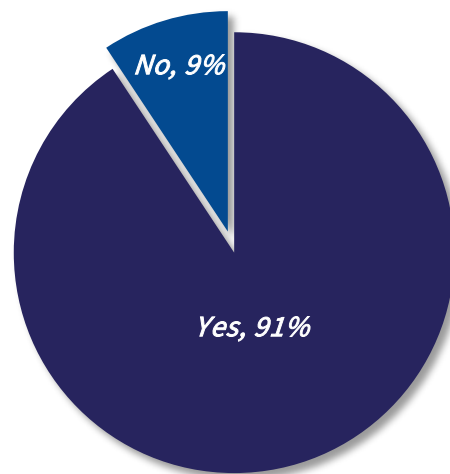

To attract more riders it is important to understand what would encourage non-users to use ART or current riders to use the service more. Respondents were asked what would make transit services more appealing. The most popular response was the bus coming every 15-30 minutes while maintaining the existing service area (37%). Approximately 24% indicated bus maintain 60-minute service mostly, but it connects to new areas. Other options, such as more night or

weekend service (17%), more technology-based on-demand transit options (14%), and improved pedestrian and bicycle connections to bus stops (8%) were also well-received, as shown in Figure 4-4.

Figure 4-4: What would make transit services more appealing for you to use it or use it more?

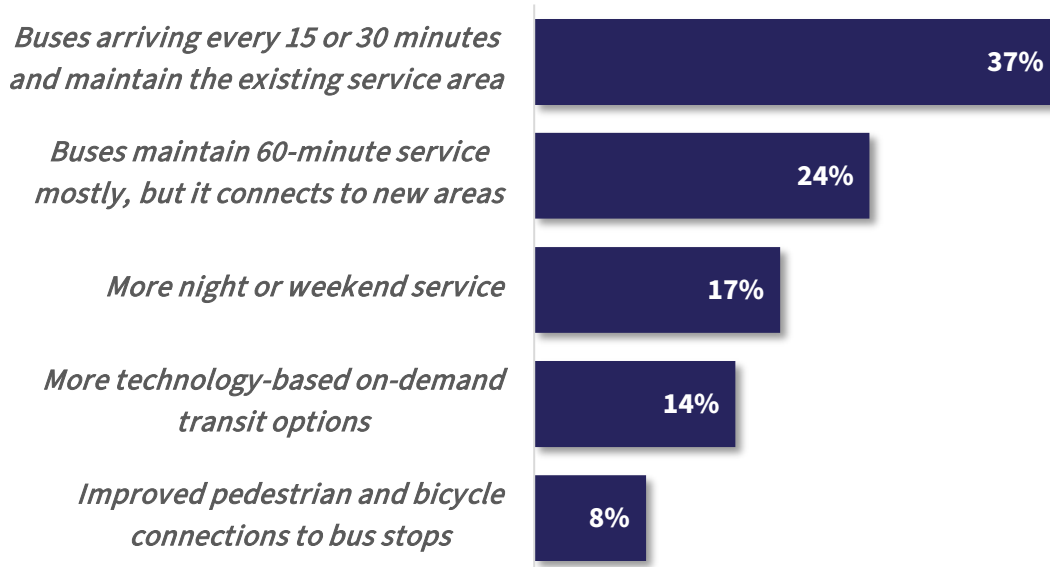

Respondents were asked where they currently (or would go) using ART services. The top 3 most popular answers were work (27%), shopping/errands (25%), and social/recreation (18%) as shown in Figure 4-5. Additionally, medical appointments (13%), education/college (9%), other (7%), and religious (2%) were other selected destinations.

Figure 4-5: If you use bus services, or decide to use them in the future, where would you use it to go?

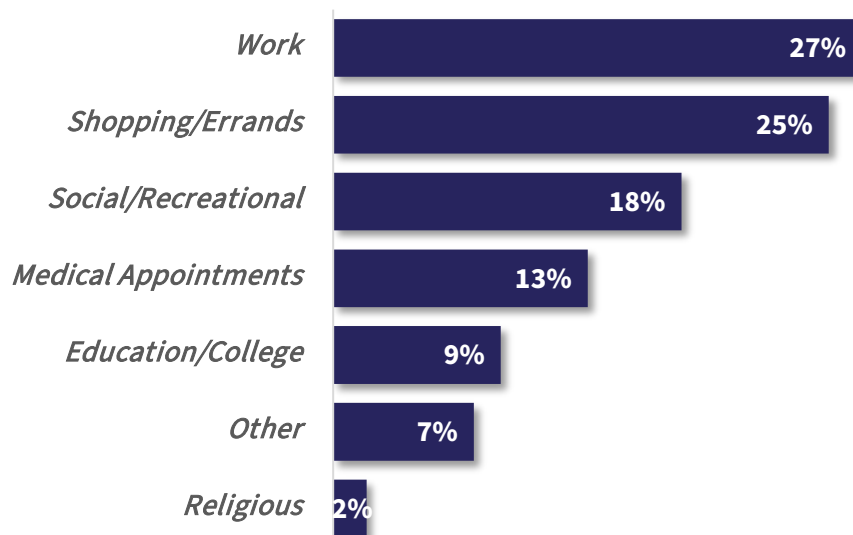

Respondents were asked to indicate what transit service improvements they would like to see in St. Lucie County (Figure 4-6). The top three responses were expanding the service area (23%), more frequent service (21%), and increasing weekend services (17%). Other responses included extending daily service hours (14%), more app-based on-demand transit (8%), more direct local and regional connections (8%), improving bus stop infrastructure (7%), other (1%), and improving sidewalk/bicycle access to bus stops (1%).

Figure 4-6: What improvements should ART prioritize over the next 10 years?

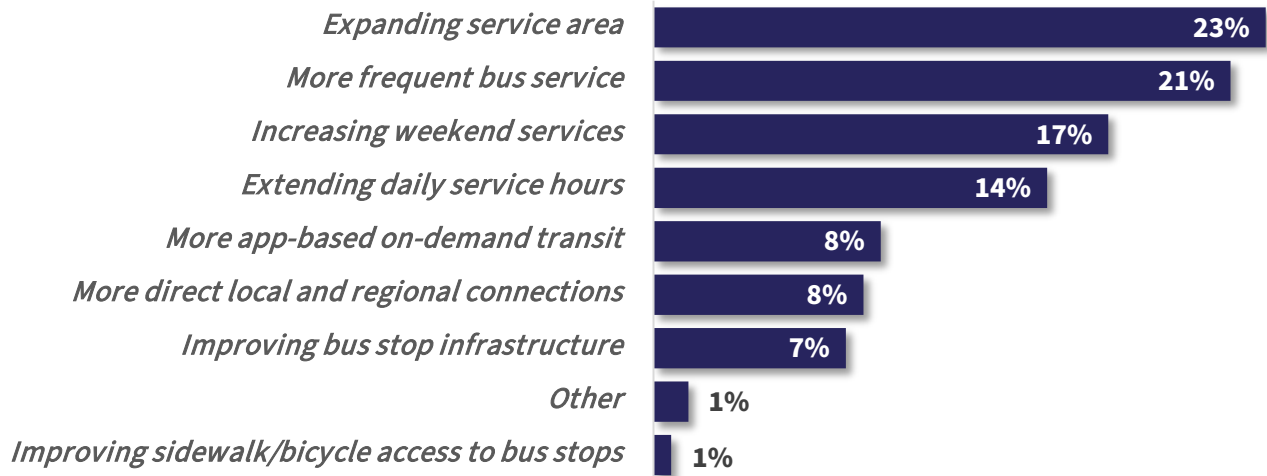

When asked if ART being fare-free encouraged respondents to use the service more, most (86%) said yes (Figure 4-7).

Figure 4-7: Currently there is no cost to ride St. Lucie County’s fixed-route service, ART. Does this encourage you to use the service more?

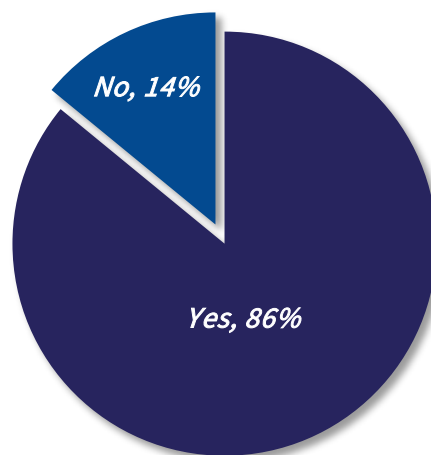

Determining commute patterns is important to ensure riders are properly served. Most respondents (69%) indicated that, post pandemic, they still commute to work 5+ days per week (Figure 4-8). An equal proportion of respondents said they work from home all the time (9%) or work from home occasionally, but commute at least 4 days per week (9%). Other respondents indicated that they work from home a couple times a week, but commute at least 3 days per week (7%); they work from home most of the week and commute only 1-2 days per week (5%); or they work from home most of the week and commute only a few times per month (2%).

Figure 4-8: If you are currently employed, how has your work commute changed since the pandemic?

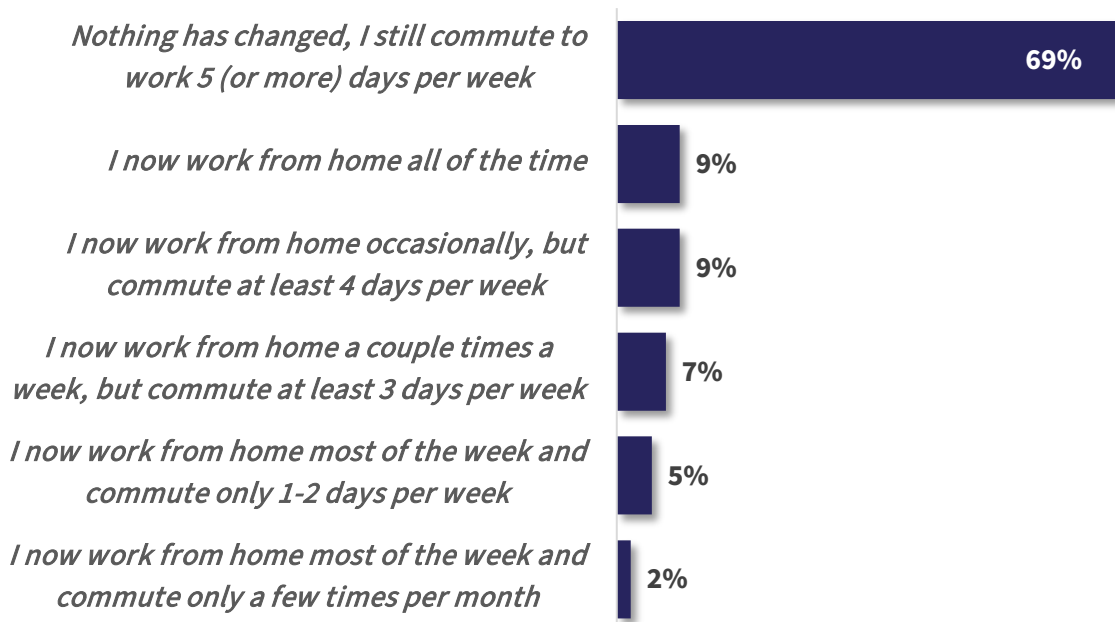

Respondents were asked to provide socio-demographic information, including work and home ZIP code, age, access to a personal vehicle, gender, ethnicity, race, and income. As shown in Maps 4-1 and 4-2, respondents selected the zip code of their residence and work. Most respondents indicated they live in zip codes 34952 (Port St. Lucie), 34953 (Port St. Lucie), or 34987 (unincorporated St. Lucie County) and work in 34982 (Fort Pierce), 34952 (Port St. Lucie), or 34950 (Fort Pierce).

Map 4-2: Home ZIP Codes

Map 4-2: Work ZIP Codes

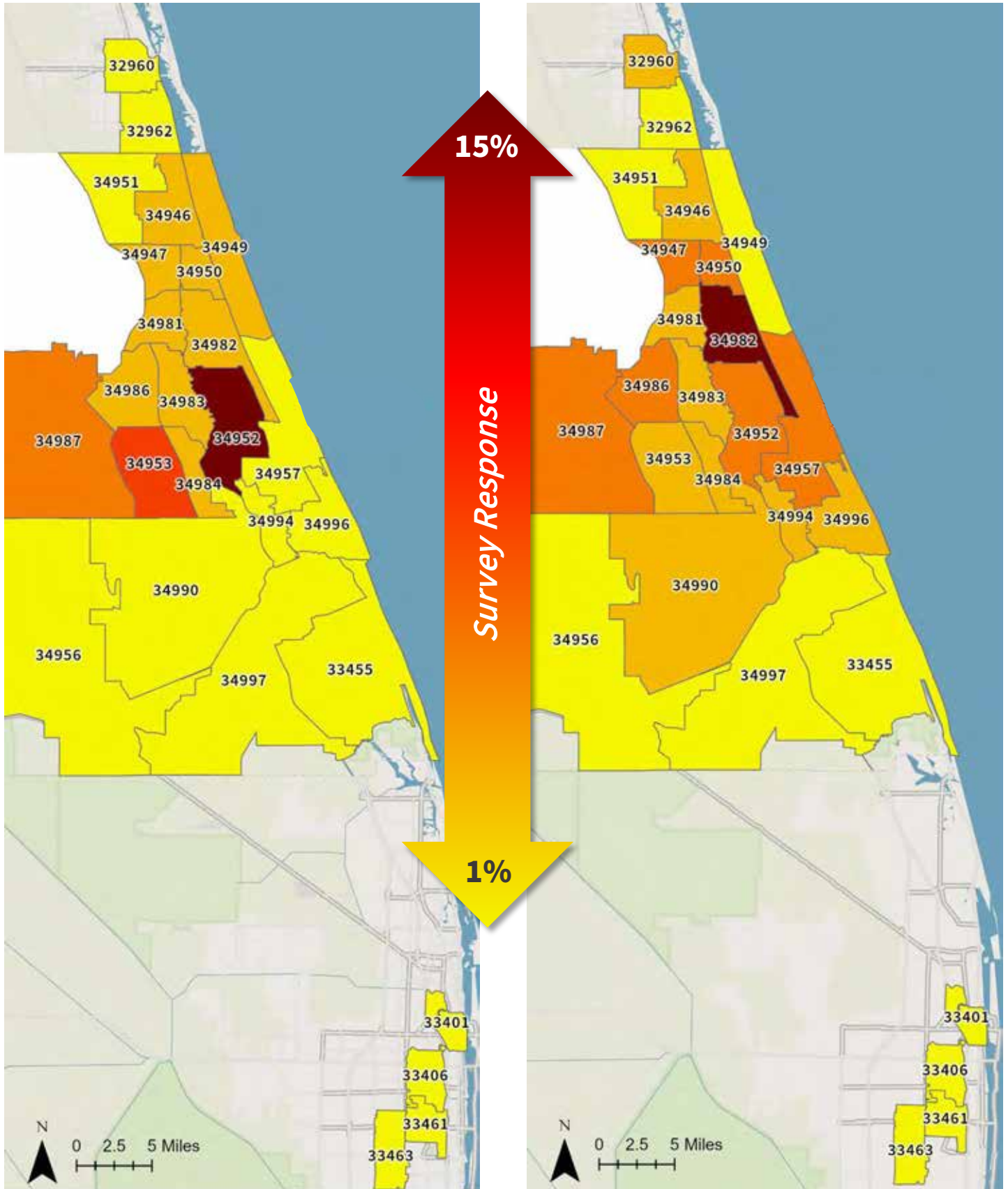

When asked their age, two-thirds of respondents fall in the range of 41-60 years old (33%) or 25 to 40 years old (33%). Approximately 17% are over 60 years old, 10% are 18-24 years old, 5% are 17 years or under, and 2% preferred not to answer (Figure 4-9).

Figure 4-9: How old are you?

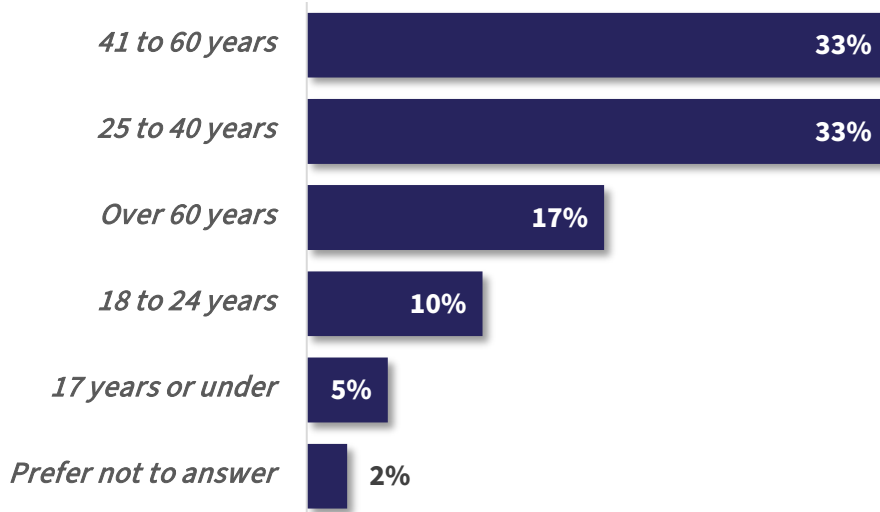

Respondents were asked about access to a personal vehicle. Most (67%) indicated they have access to a vehicle, 29% do not, 2% preferred not to answer, and 2% indicated “other” (Figure 4-10).

Figure 4-10: Do you have access to a personal vehicle?

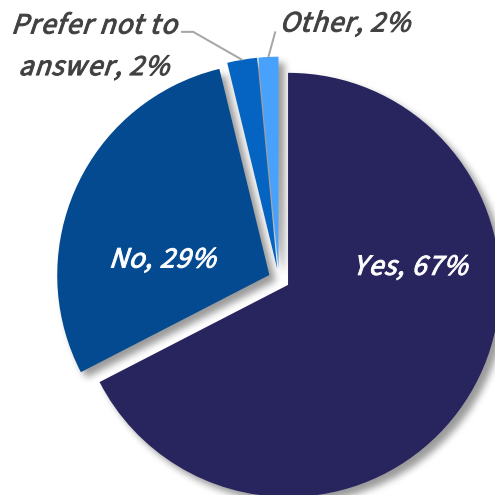

Respondents were asked their gender. The majority identify as female (63%). The remaining identify as male (32%) or some other gender (2%), as shown in Figure 4-11. Approximately 3% indicated they would prefer not to answer.

Figure 4-11: Gender

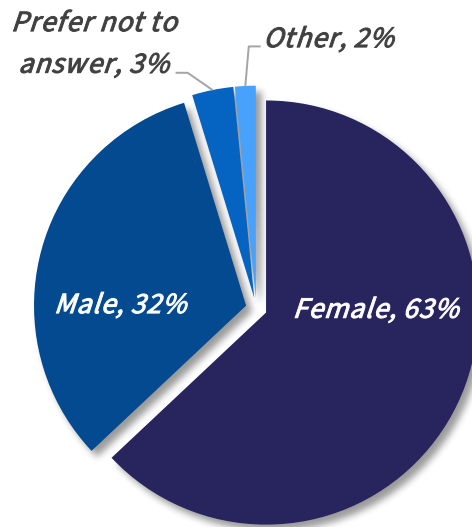

Survey respondents were asked their race and ethnicity. Figure 4-12 shows that 61% identify as White/Caucasian. The remaining respondents are Black/African American (18%), some other race (5%), American Indian/Alaska Native (2%), or Asian (2%). Approximately 11% preferred not to answer.

The majority of respondents, 65%, identified as Non-Hispanic/Latino and 20% identified as Hispanic/Latino, as shown in Figure 4-13. Approximately 15% preferred not to answer.

Figure 4-12: Race

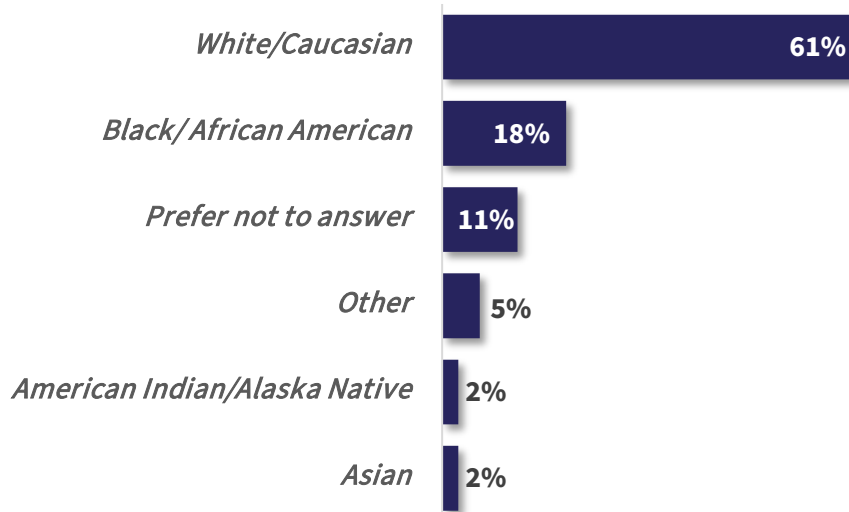
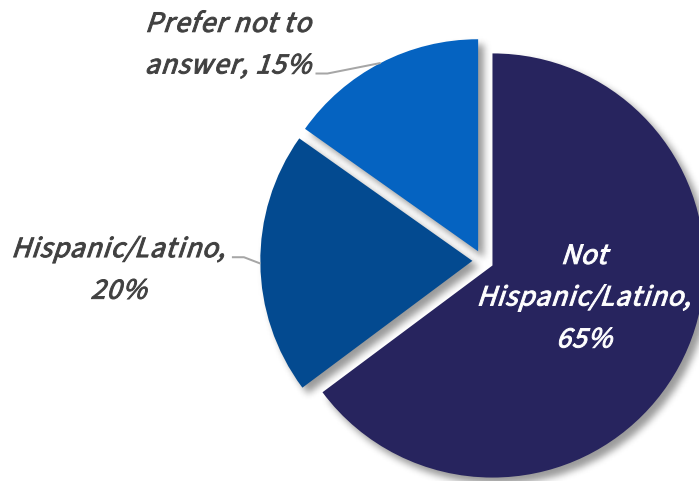
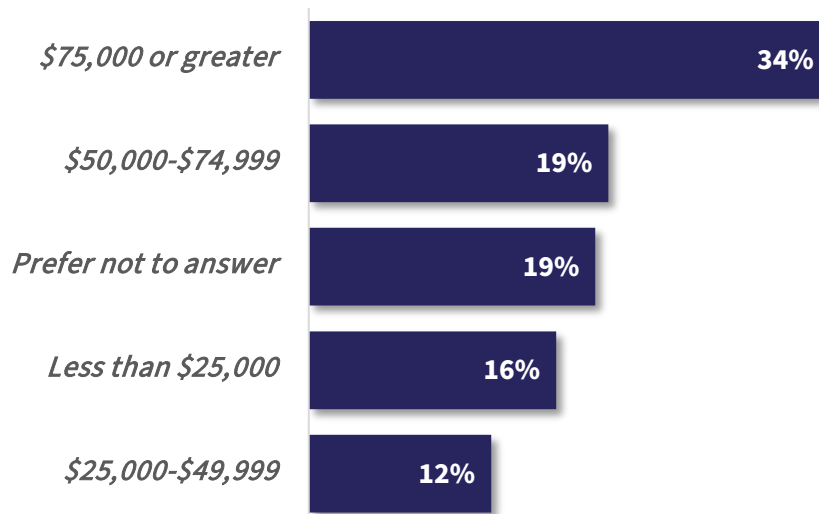

Figure 4-13: Ethnicity



As shown in Figure 4-14, approximately 34% of survey respondents indicated an annual household income over \$75,000. Other responses include \$50,000 to \$74,999 (19%), 16% indicated under \$25,000, and 12% responded \$25,000 to \$44,999. Approximately 19% preferred not to answer. According to the ACS, approximately 38% of St. Lucie County households earned more than \$75,000 and 18% earned less than \$25,000 in 2021.

Figure 4-14: Household Income





Phase II Outreach

Open House Public Workshops

Two workshops were held later in the TDP planning process to present the proposed 10-year transit improvements plan for St Lucie County to the general public and to obtain feedback to help prioritize the proposed improvements. Each was an open-house style format in which participants could come and go as they pleased and engage in discussions. Each attendee was encouraged to complete a transit priorities survey.

The workshops were attended by 77 participants, with 55 attending Port St. Lucie and 22 in Fort Pierce.

Workshop #1 – Port St. Lucie

The first public workshop was held at the Paula Lewis Branch Library. It was conducted by ART staff, St. Lucie TPO staff, and the project consultant team from 9:00 AM to 12:00 PM on February 13, 2024. As indicated previously, the

workshop was attended by 55 participants who asked questions and provided input. The participants who attended also viewed the display boards and materials showing existing service information, transit needs, and transit accessibility. Surveys were available in printed and tablet formats to allow the provision of feedback. The majority of attendees reported that they are ART riders or were interested in using the service.

Workshop #2 – Fort Pierce

On February 13, 2024, the second Phase II public workshop was held at the Fenn Center in Fort Pierce from 2:00–4:00 PM. The workshop was attended by 22 participants who interacted and provided valuable feedback.

Similar to the first public workshop, the display boards with project information were available, as were printed and tablet surveys, and information for those who were interested in learning more about ART’s current services. Like the first workshop, the majority of participants identified themselves as current riders. Following the same format as the first workshop, after viewing the presentation and reviewing the workshop material, including display boards, the feedback and discussion was received.



Transit Priorities Survey

Beginning in February 2024, a second TDP survey was made available online to the general public to provide their input on the recommended transit priorities. The survey was promoted on St. Lucie TPO social media and website, emails to stakeholders, and it also was made available at all in-person public workshops. In total, 170 surveys were completed; a copy of the survey instrument is provided in Appendix D.

Respondents were asked to rate their support for potential service alternatives. The survey was presented with a map online and multiple display boards at the in-person workshops.

The first question asked survey participants if they or a member of their household have used ART. Then they were asked to rank their support for the proposed service alternatives. The service improvement with the most support was adding 30-minute service on Routes 1 and 3 (92%), followed by Downtown/Passenger Rail/Beach Shuttle (90%), and then extending weekday service to 10 PM (89%). All suggested service alternatives were received favorably, with “strongly support” being the most frequently selected for each option proposed. Figure 4-15 shows all service improvements ranked by strong support responses.

Figure 4-15: Transit Priorities Survey Results

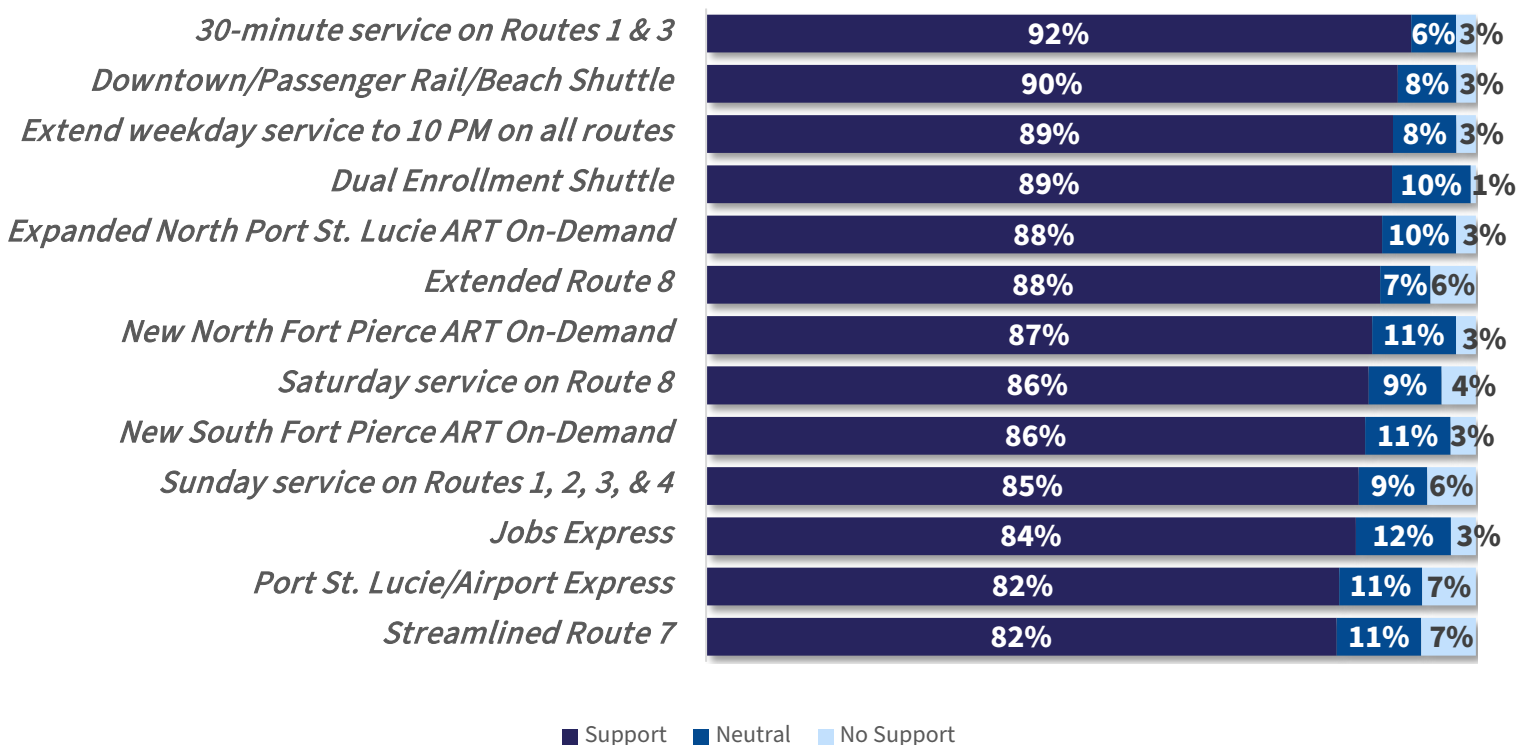

Note: Percentages may not add up to 100% due to rounding.

Web and Social Media Outreach

Both indirect and direct public outreach techniques were used to enhance the effectiveness of the *Reimagine Transit* TDP public participation process. Several indirect outreach methods described below were also used to educate and inform the public about the TDP process.

ART’s website provides information on service hours, route information, and other relevant information. During this process, advertisements and content for riders and the public to inform on the latest TDP outreach events and updates were also posted. Additionally, ART and the TPO used their respective websites to encourage the public to take TDP surveys and attend the public workshops.

Email

Numerous emails with information about the online survey, upcoming public workshops, and the general TDP development process were used to engage and encourage public participation. Stakeholders and discussion group members were sent email notices and reminders for upcoming events such as the public workshops and encouraged to redistribute the information to other interested parties.

Media

St. Lucie County and the St. Lucie TPO also used their social workshops and online TDP surveys. With Facebook, Nextdoor media was used as another platform to allow the public to Furthermore, local news media attended the second phase

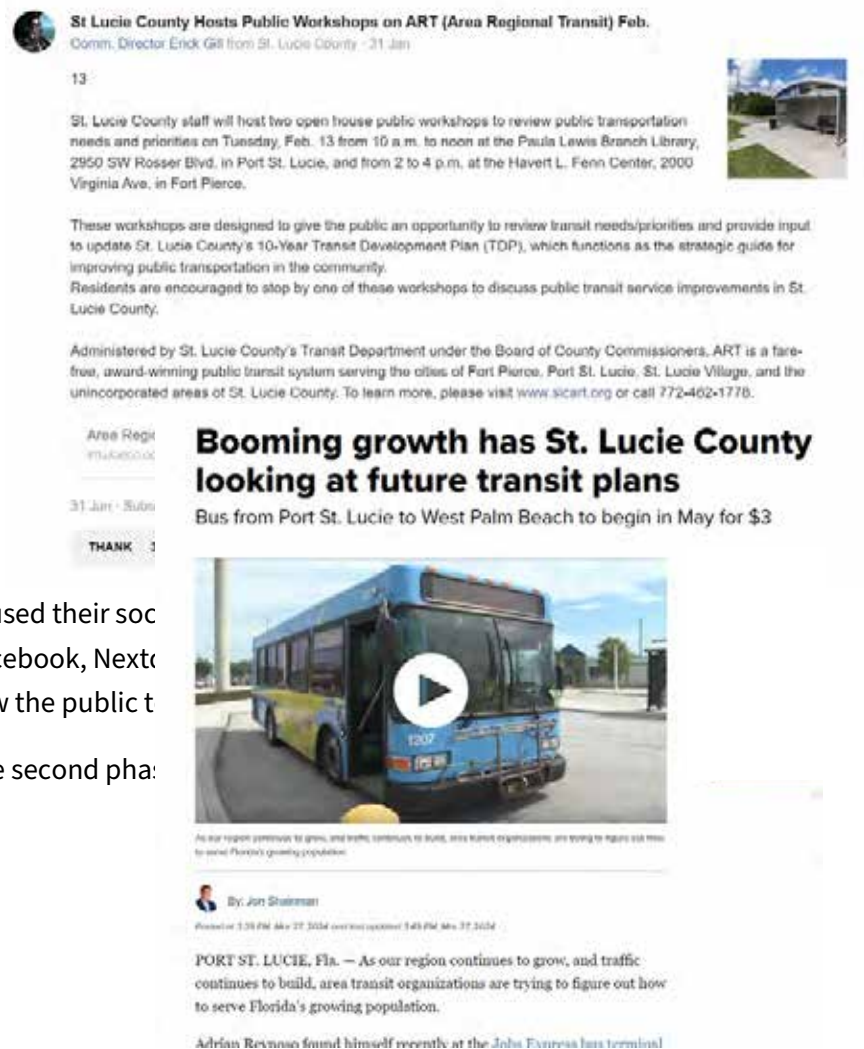

Source: WPTV

Section 5. Situation Appraisal

Conducting a situation appraisal as part of this TDP helps ART examine its current strengths and weaknesses. It also helps to identify existing or emerging challenges and opportunities for the provision of its services and assists in the development of future transit needs in the community. This situation appraisal is also a key requirement under the current TDP Rule.

Prior to this appraisal, a review of locally, regionally, and federally approved plans and studies relevant to this TDP was conducted. This ensures consistency between the 10-year transit plan goals and initiatives and any policies and planning efforts relevant to ART's services. The current planning initiatives/policy guidance from these plans were also reviewed to better understand the policy context under which transit operates in St. Lucie County and the region.

Review of Plans and Studies

Various public and private entities conduct studies to produce plans and policies at local and regional levels to address transportation issues and opportunities that may impact bus services in St. Lucie County and the immediate region. In addition, certain federal and state plans and regulations also may impact the provision of local transit services.

Due to these potential impacts, this plans and policy review may help ART understand and support its navigation of the existing local goals framework while concurrently pursuing its own goals for creating a viable and accessible transit system locally and for the region. Relevant transportation planning and programming documents are summarized, with an emphasis on those elements having implications for ART's services.

Table 5-1: Local Plans

Plan Title	Geographic Applicability	Year	Preparing Agency	Plan/Program Overview	Key Considerations/Implications for TDP
St. Lucie TPO Micro-Mobility Study	St. Lucie County	2022	St. Lucie TPO	This study reviewed the needs and characteristics of various low-speed transportation options, compared them to existing conditions in the transportation network, land development patterns and demographics for three distinctly different study areas and develops considerations that the St. Lucie TPO can implement or coordinate to promote more widespread and greater density of micro-mobility options throughout St. Lucie County.	<p>The study produced considerations for future transit services for each key area studied.</p> <ul style="list-style-type: none"> • Downtown Fort Pierce is well served by fixed transit routes as well as the Fort Pierce Tram, providing nearly complete coverage so as a first-last-mile effort, the focus is to increase usage of micro-mobility before focusing on increasing fixed-route bus service. • For the Torino Study Area, a micro-mobility transit circulator with a hybrid route-deviation service could connect residential development along Torino Parkway and NW Cashmere Boulevard to commercial and employment destinations along NW Peacock Boulevard, California Boulevard, and St. Lucie West Boulevard. • For the Tradition Area, plan calls to extend Route 5 south along Village Parkway to provide direct transit service between the Port St. Lucie Intermodal Facility and the large employment centers of the Tradition Innovation Center. If the Tradition in Motion (TIM) micro-mobility is extended here as anticipated, the County should coordinate but still provide direct transit service to these employment centers.
Smart Moves 2045 Long Range Transportation Plan (LRTP)	St. Lucie County	2021	St. Lucie TPO	The LRTP is the 25-year vision for St. Lucie County's multimodal transportation network and is updated every five years to respond to updated trends and community needs.	<p>The 2019 TDP served as the foundation for the long-range plan transit needs. The 2045 Transit Needs plan assumes a continuation of the current bus transit network and the following new or improved service needs:</p> <ul style="list-style-type: none"> • Increasing frequency on Routes 2 and 3, extending weekday service hours, and implementing capital and infrastructure improvements • Crosstown Parkway route • Fort Pierce to South Hutchinson Island connector • Route 5 split on Gatlin Boulevard and Port St. Lucie Boulevard • Midway Road connection • Palm Beach Express • Selvitz Road and Bayshore Boulevard route • Route on Virginia Avenue • Passenger train connecting Miami to Orlando • Adding microtransit service in Indian River Estates/adjacent to Torino Parkway
Jobs Express Terminal Connectivity Study	St. Lucie County	2020	St. Lucie TPO	The study reviewed multimodal connectivity to/from the Jobs Express Terminal that was programmed for construction in 2020. The terminal is expected to support regional commuter trips to and from the St. Lucie County area. The study effort included a multimodal safety assessment of Gatlin Boulevard/Tradition Parkway from west of Village Parkway to east of Rosser Boulevard. The assessment included evaluating, transit, bike, and ped network connectivity to the site.	<p>The following transit improvements were considered within the two-mile radius of the study area, in addition to numerous pedestrian and bicycle safety and connectivity improvements to access the Jobs Express Terminal.</p> <ul style="list-style-type: none"> • Short-term Recommendations - Provide enhanced Treasure Coast Connector microtransit service within designated mobility zone(s) including connecting persons to the Jobs Express Terminal, fixed-route, and commuter bus service. • Mid- and Long-term Recommendations - For Gatlin Boulevard, improve bus stop facilities within the study area to include: boarding/alighting area, sidewalk connection, shelter and bench, and ADA accessibility. Review transit routes to the Jobs Express Terminal to improve connectivity to/from nearby neighborhoods (i.e., circulator routes) with peak-period short headways
St. Lucie County 2020-2029 TDP Major Update	St. Lucie County	2019	ART/St. Lucie TPO	The State of Florida Public Transit Block Grant Program requires urban public transit service providers to develop and adopt a 10-Year TDP per FDOT requirements. Major updates must be completed every five years and include an assessment of baseline conditions, a public involvement plan, and ridership estimates.	<p>The adopted TDP Needs Plan calls for enhancing current services by expanding service span, weekend service, adding new microtransit service, new fixed-routes, and needed capital, infrastructure, and information technology investments. The funded implementation plan include:</p> <ul style="list-style-type: none"> • Increase frequency on Routes 2 and 3 • Add new service connecting Fort Pierce to Port St. Lucie via 25th Street • Torino Parkway microtransit service

Table 5-1: Local Plans (Continued)

Plan Title	Geographic Applicability	Year	Preparing Agency	Plan/Program Overview	Key Considerations/Implications for TDP
St. Lucie County 2021 TDP Annual Progress Report	St. Lucie County	2021	ART/St. Lucie TPO	TDP Annual Progress Report, provides status report on transit improvements identified in the Bus Plus 2020-29 TDP Major Update.	<p>Provided updates on variety of service and capital projects in the last TDP major update.</p> <ul style="list-style-type: none"> Fort Pierce/Port St. Lucie Express (25th Street) - The new Route 8 on 25th Street was implemented in 2020. Palm Beach Express -The new commuter service operated by Palm Tran is expected to be implemented soon. Fort Pierce to South Hutchinson Island - Funding award is pending and the project was set to start in 2022. Tradition/Gatlin Area Microtransit was Implemented in 2020, The microtransit pilot project was later incorporated as a permanent option of the transit system. Torino Pkwy Microtransit - Funding award is pending and the project was set to start in 2022 in Port St. Lucie. New Administration & Operations Facility – With initial funding from CARES Act, this is set to be completed by 2023 Port St. Lucie Intermodal/Passenger Area – This has not been started yet but funding is on track.
Automated Connected Electric and Shared-Use (ACES) Sustainable Transportation Plan	St. Lucie County	2023	St. Lucie TPO	The ACES vehicle network will continue to consider infrastructure improvements that expand capacity, using all transportation modes, more effectively using existing structure in St. Lucie County.	<p>This plan proposes ACES Mobility Hubs, or centers that integrate placemaking and transportation, throughout the county. Hub locations were determined by geographic, operational, emergency and resiliency, land use, and equity factors then prioritized as follows (in order):</p> <ul style="list-style-type: none"> Fort Pierce Downtown (Orange Avenue and FEC Railroad) Becker Road (I-95 Interchange and Becker Road) Okeechobee Road (Okeechobee Road and I-95 Interchange to Fort Pierce West) US 1 & Port St. Lucie Boulevard (Intersection of US 1 & SE Port St. Lucie Boulevard) Midway Road (I-95 Interchange and Midway Road) St. Lucie West (I-95 Interchange and St. Lucie West Boulevard) Crosstown Parkway (I-95 Interchange and Crosstown Parkway) Port St. Lucie Boulevard and Airoso Boulevard (Port St. Lucie Boulevard & Florida’s Turnpike/Airoso Boulevard) Orange Avenue (I-95 Interchange and Orange Avenue) Indrio Road Planned Development (I-95 Interchange and Indrio Road)
Congestion Management Process Major Update	St. Lucie County	2018	St. Lucie TPO	The plan Identifies and prioritizes projects that improve transportation system performance and reliability to submit to the FDOT Five-Year Work Program, the TPO’s List of Priority Projects (LOPP), and the TPO’s Transportation Improvement Program (TIP).	<p>Evaluates roadway segments and identifies those that need further congestion mitigation. Multimodal improvements include pedestrian infrastructure and public transit. Road segments with public transit that were identified for further congestion mitigation include:</p> <ul style="list-style-type: none"> Gatlin Boulevard (west of I-95 to Port St. Lucie Boulevard) St. Lucie West Boulevard (I-95 to Bayshore Boulevard)
Transportation Disadvantaged Service Plan (TDSP)	St. Lucie County	2023	ART/St. Lucie TPO	The St. Lucie County TDSP addresses the needs of elderly, disabled, or economically disadvantaged people within the county. It reflects a careful review of various data, travel patterns, policies, agency responsibilities and funding to define a five-year detailed implementation plan (which is updated annually) to help meet those needs.	<p>Anticipates the need for an increasing transportation disadvantaged population including people with disabilities, elderly, and low-income. The implementation plan includes the following ongoing needed system improvements:</p> <ul style="list-style-type: none"> Increase fixed-route utilization and maintain/increase the number of passengers per vehicle hour Manage the cost per passenger trips and the cost per vehicle hour Implement innovative pilot programs for after-hours transportation services Identify additional park and ride lots within St. Lucie County Install bus shelters

Table 5-1: Local Plans (Continued)

Plan Title	Geographic Applicability	Year	Preparing Agency	Plan/Program Overview	Key Considerations/Implications for TDP
St. Lucie County Comprehensive Plan	St. Lucie County	2022	St. Lucie County	Primary policy document that addresses land use, transportation, capital projects, public facilities, and economic development goals, among others, for the county.	<p>Promotes public transit as a sustainable transportation option in St. Lucie County. Prescribes several transit-supportive goals, objectives, and policies, such as the need to support efforts to extend passenger rail service, protect right-of-way for exclusive mass transit corridors, and coordinate with other transit agencies to meet regional mobility needs. Policies supportive of transit include:</p> <ul style="list-style-type: none"> • Promote transit use to reduce greenhouse gas emissions • Assist local coordinated community providers to find additional state and federal funds to expand service • Promote transit use through marketing and public information efforts • Continue to monitor the demand for transit in St. Lucie County
City of Fort Pierce Comprehensive Plan	City of Fort Pierce	2020	City of Fort Pierce	Primary policy document that addresses land use, transportation, capital projects, public facilities, recreation, government coordination, conservation, and development goals, among others, for the city	<p>Encourages alternative transportation options to alleviate traffic along major roadways. Transit-supportive goals, objectives, and policies include:</p> <ul style="list-style-type: none"> • Support multimodal transportation through site design and development standards, including promotion of transit-oriented development principles • Develop a transportation demand management (TDM) program to encourage vanpool use and accessibility to transit • Implement complete streets designs and seek to decrease the modal split for single-occupant vehicles • Enhance transit services along US 1, including the possibility of contributing to ART or support facilities to mitigate traffic • Implement pedestrian and transit infrastructure on all primary city corridors
City of Port St. Lucie Comprehensive Plan	City of Port St. Lucie	2020	City of Port St. Lucie	Primary policy document that addresses land use, transportation, capital projects, public facilities, recreation, government coordination, conservation, and development goals, among others, for the city	<p>Emphasizes the need for a safe and convenient multimodal network. Policies that are supportive of transit include:</p> <ul style="list-style-type: none"> • Increase transit ridership and coordinate with the county to expand the number of future transit routes • Establish new transit facilities and routes to meet demand and construct new transit amenities/new bus stops on new and existing routes • Encourage new developments to support transit amenities • Support regional transit system

Table 5-2: Regional Plans

Plan Title	Geographic Applicability	Year	Preparing Agency	Plan/Program Overview	Key Considerations/Implications for TDP
Indian River County (IRC) 2024-2033 TDP Major Update	Indian River County	2023	Indian River County	The IRC TDP Major Update includes a strategic guide for GoLine service with funded and unfunded service recommendations (as part of its funded short-term plan and unfunded long-term plans).	<p>The adopted TDP calls for improving the current service quality by expanding service span, weekend service, and needed capital, infrastructure, and information technology investments. The funded Short-term service enhancements include:</p> <ul style="list-style-type: none"> • Weekday Service Span from 7:00 p.m. to 9:00 p.m. (FY 2025) • Saturday Service Span of 7:00 a.m. to 7:00 p.m. (FY 2027) • Addition of Route 13 service on Saturdays (FY 2027) • Addition of Sunday service (FY 2029) <p>The plan does not mention any new services to St. Lucie County in the next 10 years.</p>
Martin County 2020-2029 TDP Major Update	Martin County	2019	Martin County	TDP Major Update guides Marty services over the next 10 years, as currently required by Florida law. The TDP derives transit and mobility needs, cost/revenue projections, and community transit goals, objectives and policies.	<p>Recommends a number of improvements to the Marty transit system, including enhancements to existing fixed-route services, new local and regional routes, and new local microtransit services. It is recommended the existing Route 1, which connects to ART at the Treasure Coast Mall, extends service hours to 8:00-10:00PM and adds Saturday service. The plan does not mention any new service connections to St. Lucie County in the next 10 years.</p>

Table 5-3: State Plans

Plan Title	Geographic Applicability	Most Recent Update	Responsible Agency	Plan/Program Overview	Key Considerations/Implications for TDP
State of Florida Transportation Disadvantaged 5-Year/20-Year Plan	Florida	2007	FCTD	Accomplish cost-effective, efficient, unduplicated, and cohesive TD services within its respective service area. Includes the explanation of the Florida Coordinated Transportation System, five-year report card, Florida Office of Program Policy Analysis and Government Accountability Review, and a strategic vision and goals, objectives, and measures.	<ul style="list-style-type: none"> • Develop and field-test model community transportation system for TD persons; create strategy for Florida CTD to support development of universal transportation system. • Long-range strategic vision includes developing a universal cost-effective transportation system with a uniform funding system and services that are designed and implemented regionally throughout the State.
FDOT Complete Streets Implementation Update: Handbook and Design Manual	Florida	2018	FDOT	Developed to create alternative transportation systems to facilitate Complete Streets focused design.	<ul style="list-style-type: none"> • Revising guidance, standards, manuals, policies, and other documents. • Updating how decision-making is processed. • Modifying evaluation of performance. • Managing communication between agencies. • Updating training and education in agencies.
Florida Transportation Plan	Florida	2020	FDOT	Florida’s long-range transportation plan, as required by state and federal law.	<p>Supports development of State, regional, and local transit services through series of related goals and objectives, emphasizing new and innovative approaches by all modes to meet needs today and in future. Most recent update emphasizes:</p> <ul style="list-style-type: none"> • Safety and security for Florida’s residents, visitors, and businesses. • Resilient and quality infrastructure. • Connected, efficient, and reliable mobility for people and freight. • Transportation choices that improve equity and accessibility. • Transportation solutions that strengthen Florida’s economy. • Mobility solutions that enhance Florida’s communities. • Transportation systems that enhance Florida’s environment.
Infrastructure Investment and Jobs Act	USA	2021	117 th US Congress	Reauthorizes and expands federal funding for the nation’s surface transportation infrastructure, including transit systems and rail transportation network. Maintains strong commitment to safety.	<p>Authorizes federal funding to advance public transportation through safety, modernization, climate, and equity.</p> <ul style="list-style-type: none"> • Includes \$33.5 billion for transit capital and operating assistance in urbanized areas and \$4.6 billion to support rural transit systems. • Funds dedicated to repairing and upgrading existing infrastructure, increasing accessibility, expanding service areas, upgrading buses to zero-emissions models. • Increases funding to meet transportation needs for older adults and people with disabilities. • Provides \$12 billion in partnership grants for intercity rail service.
Implications to Public Transportation of Emerging Technologies	USA	2016	National	National Center for Transit Research	White paper that explores possible consequences for public transportation as result of introduction of new technologies such as autonomous vehicles, connected vehicles, and other innovations that impact efficiency, cost-effectiveness, and overall demand for transportation.

Situation Appraisal

Transit systems function best when the many factors that can impact providing services effectively and efficiently are known. A “situation appraisal” is an assessment process that is specifically infused with a strategic planning focus to help identify and quantify/qualify such factors.

This section summarizes the situation appraisal conducted for ART so that staff, stakeholders, and other constituents will better understand the system’s local operating environment. The situation appraisal assesses and documents the key aspects of the transit operating environment, examines the strengths and weaknesses of the system, and identifies existing barriers or threats to the provision of transit service in the county. This appraisal can assist identifying key opportunities for addressing threats and/or enhancing the transit-friendliness of the operating environment, as summarized in the remainder of this section.

Development and Growth Trends

It is beneficial to understand the demographic trends and markets that can impact public transportation services. Key findings from the assessment of socioeconomic and demographic trends for this TDP are summarized below.

- St. Lucie County is projected to have over 480,000 residents by 2050, more than a 30% increase over the current population.
- Currently the 65 and older age cohort is 23.6% of the population. This age group will continue to grow, peaking at 26.7% in 2045.
- More than one in three jobs located in St. Lucie County are in the educational services, health care and social assistance, or retail trade industries. Areas between the Florida Turnpike and S 25th Street, north of Midway Road are expected to increase in employment density in the coming decade.
- Although 38% of St. Lucie County households have an annual income of \$75,000 or more, 18% earn \$25,000 or less.
- Approximately 4.4% of households in St. Lucie County are zero-vehicle households. Approximately 78% of households own one or two vehicles.

St. Lucie County is projected to increase its population by 30% by 2050. Currently, nearly 24% of the population is 65 and older and approximately 45% of the population identify as non-White minorities. Of this 45%, 20% identify as Black/African American and 20% Hispanic.

Implications

Since the pandemic, St. Lucie County has continued to grow in population and jobs, creating more demand for alternative modes of transportation like transit. The older adult population, which has a higher tendency to use transit, is projected to grow more rapidly and eventually become more than one in four of the population by 2045.

There are still sizable segments of minorities and low-income households in the county. These demographic characteristics are typically considered to be more inclined to use public transportation, an indication of why St. Lucie County should continue to provide and improve transit for access to jobs and other services. While traditional riders should be a key focus for service, ART should also aim to attract more discretionary riders, or riders who have the choice of riding or driving their own vehicle. Key considerations for ART include enhancing mobility options and promoting more efficient use of commute times for these potential riders with high frequency and more direct routes, as well as enhanced marketing of existing and proposed services.

Travel Behavior and Patterns

It is important to understand existing travel and commuting behaviors and patterns to determine possible impacts or benefits affecting public transit services. Some key findings are as follows:

- Although post-pandemic (2022) commuters in St. Lucie County continue to use their personal vehicles to commute (80.9%), the share of those who worked from home reached nearly 7%.
- According to the ACS, most public transit users (71.8%) and those who drive alone (43.6%) report leaving home between 7:00AM and 9:00AM, the traditional peak traffic hours.
- Most non-freeway automobile travel, primarily with a single occupant, continues to be on US 1. Growth in the Port St Lucie area has added other high-traveled roadways, including Crosstown Parkway, Port St. Lucie Boulevard, and St. Lucie West Boulevard.
- The average commute time in St. Lucie County is 28.6 minutes. More than half (56.6%) of transit users report a travel time between 30 to 59 minutes while 37.9% of those that drove alone indicated their commute time was between 15 to 29 minutes.

Travel patterns show 47% of commuters into St Lucie County come from Martin and Palm Beach counties and 78% of St. Lucie commuters leave to work in these two counties.

Implications

While ART already serves most high population and job density areas, to capture more discretionary riders it may need to consider increasing frequencies during peak hours and on key corridors. Operating more frequent service, while expensive, may be the best way to encourage new riders as the average commute time while driving is currently less than 30 minutes. This suggests that convenience of car travel still may be hindering additional discretionary ridership for transit.

Furthermore, data from the ACS indicate that more than one-third of St. Lucie County residents are employed in educational services, health care and social assistance, or retail industries, which can have fluctuating work schedules that may require travel during later hours at night. ART should explore supplying earlier/later service in areas where there are major hospitals or shopping centers.

Continued suburban growth outside of ART’s current service area will continue to be a challenge, as ART must balance increasing service in existing core areas against demand for expanding services to new areas. As traditional bus service travels through congested corridors, new services such as express bus may be considered to connect frequently accessed destinations, shortening travel time for riders. In less populated areas, services like on-demand microtransit may help with connecting suburban communities and outlying neighborhoods, offering transportation alternatives.

Land Use/Urban Design/Growth

St. Lucie County is currently in the top 20 most populous Florida counties and ranked sixth in population growth in Florida in 2022, according to University of Florida’s Bureau of Economic and Business Research (BEBR). Furthermore, both Fort Pierce and Port St. Lucie are included in the top 100 most populous cities in Florida and the City of Port St. Lucie was among the top 25 cities for population growth in 2022.

Most growth is in Port St Lucie where there are five Development of Regional Impact (DRIs): Tradition, Western Grove, Riverland, Southern Grove, and Wilson Groves. While Tradition is mostly built, the remaining areas are expected to add approximately 23,500 dwelling units. Furthermore, the “Jobs Corridor” in Southern Grove, which is home to Amazon, Cheney Brothers, Fed-Ex, and the Cleveland Clinic among others, only has around one-third of space remaining and available for sale.

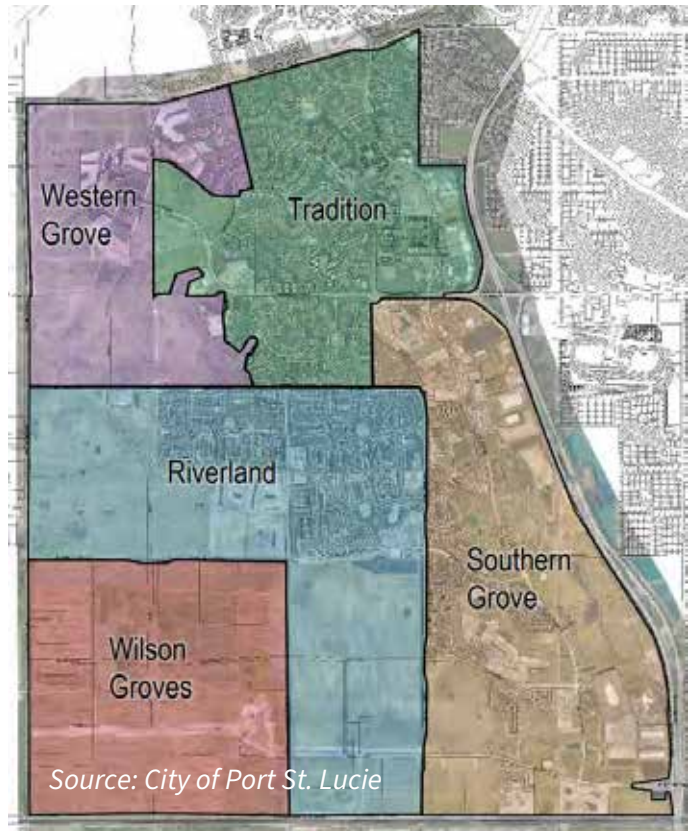

In April 2023, St. Lucie County, the City of Fort Pierce, and the Fort Pierce Redevelopment Agency (FPRA) entered an interlocal agreement (ILA) to solicit input from those in the real estate/development sector about a mixed-use affordable development in the Lincoln Park District around the Avenue D and 7th Street area. This would complement the other nearby developments like Kings Landing, and will feature retail, restaurants, and a new hotel.

Furthermore, an assessment was conducted to better examine the impact of local land use conditions and policies on public transit needs using available existing and future land use data for St Lucie County and its key municipalities. It is important to identify the current and future areas of St. Lucie County that may benefit the most from the provision/expansion of public transit services. Key findings from this review are as follows:

- In unincorporated St. Lucie County, transit-supportive land uses such as High Density Residential (greater than 15 dwelling units/acre) and Mixed Use (up to 15 dwelling units/acre) designations are found mainly along major corridors, such as US 1 adjacent to Fort Pierce city limits.
- Within Fort Pierce city limits, the Central Business District use allows for up to 30 dwelling units per acre with a density bonus.
- Most land in Fort Pierce, specifically concentrated along SR-70 and US 1, is designated for General Commercial use and Medium Density Residential. Adjacent to downtown Fort Pierce, the most popular residential land use is medium density residential.
- There is a New Community Development (up to 35 dwelling units/acre) area located west of I-95 north of the county line in Port St. Lucie. Most of Port St. Lucie is mostly designated for low-density residential uses.
- According to the St. Lucie TPO, US 1 has sidewalks and bike lanes on both sides where it connects Martin County. Adjacent land uses in the vicinity include Commercial uses.

Part of St. Lucie County’s goal is to “balance responsible growth and infrastructure with natural preservation.”

Implications

As developers invest in new and expanded neighborhoods and retail space in St. Lucie County, ART should continue to monitor and utilize any opportunity to include transit-friendly design and transit amenities. With the addition of trip generators with a diverse set of residential and commercial/retail developments and the mobility needs that come with it, ART can expect to see greater demand for its services, such as microtransit to connect locally and commuter routes to connect regionally.

ART should take advantage of this opportunity in a time of such rapid growth to continue to be involved and support changes in Port St. Lucie that will result in transit supportive higher-density/intensity developments and/or transit oriented developments (TODs). However, low-density residential land uses/development, located in the southern part of the county, may still be a challenging environment to provide efficient transit services as demand continues to grow. ART should continue to monitor route performance and adjust operations as needed to respond to changing land use and development patterns. Furthermore, ART should continue to work with municipalities and the County to strengthen Land Development Codes with development requirements that are supportive of transit.

In Fort Pierce, while most major corridors are served by ART, the 2020 FPRA Redevelopment Plan mentions the need for more transit: extended service hours, more frequency, and additional multimodal connections.

Tourism and Visitors

Tourism is important to the local economy, supporting local service jobs and affecting transportation patterns. Key findings from the assessment of tourism-related data include the following:

- More than 1.1 million tourists arrived in St. Lucie County in 2017.
- Most visitors arrive to St. Lucie County via driving.
- It is estimated that \$8.6 million annually has been generated in local sales revenue from tourists.

Implications

Seasonal residents and visitors affect the travel characteristics in St. Lucie County. Having higher demand October-April can stretch resources and shift demand to other modes. As St. Lucie County continues to welcome visitors and seasonal residents, ART can play a role in attraction connectivity and relieving traffic congestion and parking demand.

Public Involvement

ART, in coordination with the St. Lucie TPO, conducted a series of outreach events to gather input on transit needs for the *Reimagine Transit* TDP and to raise awareness of ART's services. Following are key needs identified during the TDP public involvement efforts to date:

- *Increasing Service Supply* – Stakeholders specifically identified the need for expanded service hours, including both earlier and later, as a top priority. Persons employed in service-based industries with limited transportation options are unable to use transit to work within the current service hours.
- *Higher Frequency Service* – Public feedback emphasized the need to make frequency a priority. Stakeholders have mentioned that implementing 30 minute or better headways has the potential to generate more ridership. Adding more frequent service to help connect people to economic opportunities while attracting more choice ridership also was mentioned.
- *Increasing Service Options* – The public and key stakeholders agreed that expanding microtransit services will enhance the attractiveness of transit.
- *Additional Local Connections* – The need for additional local connections serving new areas, notably on Midway Road and Bayshore Boulevard, was mentioned by the public.
- *Awareness Campaign* – Implementing an awareness/education campaign to promote existing transit services is necessary to generate new ridership. Partnering with private entities such as education centers and larger businesses to help generate interest in the services was also identified.

Implications

Input from the community indicates that ART services are an essential and an integral part of the county transportation network. Both stakeholders and the public expect ART to continue to improve transit services. Increased service supply, like 30-minute headways and expanding service hours, are needed to increase the quality of service for current riders and attract potential new

riders. These are also critical enhancements if the County desires to grow transit to become a viable transportation alternative to driving. Continued success depends on the ability of ART to adapt and implement services that will expand its rider base and capture new transit markets.

The lack of awareness of the current services was identified by most as a major hurdle to overcome, but the ongoing efforts by ART to improve awareness was acknowledged. Hiring a dedicated transit marketing coordinator may help, especially with targeted initiatives. For example, social media campaigns directed at youth and college students which research suggests are more open to transportation alternatives than previous generations, could increase awareness among this group of potential riders.

ART has a unique opportunity to use this public input to “reimagine” various aspects of its network due to modified/changed travel patterns post COVID-19 pandemic. If more people work from home and some decide to forgo their personal vehicles or not use them due to the burden of carrying insurance, that may provide an opportunity for ART to fill that gap to connect them to goods and services.

Organizational Attributes and Funding

ART operates as a stand-alone County department managed by a Transit Director and includes seven dedicated staff who administer ART’s fixed route, paratransit, microtransit, and special transportation services. The fixed-route and paratransit services are operated by a third-party contractor MV Transportation.

The St. Lucie Board of County Commissioners (BOCC) is the governing body for ART and is tasked with providing funding support and approving the TDP and other transit-related initiatives.

ART is primarily funded by the St. Lucie Transit Municipal Services Taxing Unit (MSTU), established in 2002 to generate local funds to leverage state and federal funding for public transit. Recently, the BOCC approved an increase in the millage rate for transit services, from 0.1269 to 0.2500, starting in FY 2023. It also extended the Transit MSTU Interlocal Agreements through December 31, 2041. ART is among the limited transit agencies in Florida with a dedicated source of funding, providing a solid base for ART to plan future services and leverage state and federal grants/funds.

This organizational structure has changed since the previous TDP was adopted. Known as the Treasure Coast Connector, the county’s transit system was formerly operated by the St. Lucie Council on Aging.

Implications

Stakeholders and the public commented on the positive impact ART has made with its current management and organizational structure/administration. Throughout the public involvement process, stakeholders and discussion group members commended ART for its ability to navigate the pandemic, a difficult task for any transit agency. In addition to showing resiliency, ART has used the

pandemic as a “reset” to rebrand and establish a solid foundation for expanding transit with the addition of app-based microtransit services.

With the increased millage rate, leveraging new state and federal revenue sources should be a priority for ART. As improved transit services may attract more visitors and can bolster economic development by connecting workers to jobs, municipalities may also be open to dedicating a portion of their local funds as an investment/fair share allocation for transit. With improved transit service and other riding arrangements with ART, hotels may be able to rely on transit services to provide necessary transportation to their guests, resulting in hotels moving away from transporting people via their private shuttles. Private partnerships with local businesses and education centers may also be a viable avenue of funding and should be explored. The TDP should be used as a strategic blueprint that ART needs to explore these local options to make transit better work for its community and the region in the next 10 years.

Technology

ART continues to implement technologies to improve the quality of its services and enhance the overall transit riding experience for its patrons. In addition to various software and hardware/infrastructure upgrades to its fleet and facilities, ART should continue to offer technology upgrades to passengers.

Furthermore, the addition of zone-based microtransit also has added more technology and tools to ART. As part of this service, it has launched the *ART On-Demand* microtransit app for users and added various software platforms for the driver/dispatch to plan those trips.

Considerations for additional technology upgrades for ART may include the following:

- *No/low emission Alternative Fuel Buses: Electric Vehicles (EVs)* – Currently, ART operates a fleet of vehicles powered by fossil fuels. When replacing buses over the next 10 years, considering vehicles with no/low emission fuel technologies like electric, CNG, or electric- hybrid may help reduce ART’s carbon footprint while also improving its image as a technologically-advanced and an environmental-friendly option for travel. Although the upfront capital cost of these vehicles may be higher, they may offer longer-term savings on fuel costs.
- *Wi-Fi* – Providing Wi-Fi at major transfer locations and inside buses can offer convenience to riders and an additional incentive to use transit. Providing Wi-Fi on buses also can help improve the quality of the rider’s experience and help market the bus ride to discretionary/choice riders. The initial Wi-Fi login page can be an alternative way for ART to communicate important information to riders, such as service changes, request feedback via surveys, etc.
- *Transit Signal Priority (TSP)/Queue Jumps* – With traffic congestion increasing due to growth, applying TSP and queue jumps at high volume/congested intersections may help increase bus travel times and the attractiveness of ART.

Implications

ART should continue to invest in new and emerging technologies to increase the accessibility and attractiveness of its services as it strives to attract new riders, while increasing the quality of the experience for existing riders. Adding technologies, like Wi-Fi on buses, may attract those looking to make their commute more productive. Additionally, transitioning to EVs, may allow ART to attract riders who are environmentally conscious and take advantage of federal and state grant opportunities to help fund no or low-emission transit vehicles.

Furthermore, ART should work with its local and regional partners, including FDOT, St. Lucie TPO, and St. Lucie County to implement bus preferential treatments, such as TSP and/or queue jumps on corridors such as US 1. As this may require collaboration across agencies, ART should initiate discussions on infrastructure constraints and operational considerations well before implementation of such treatments.

Regional Coordination

The primary way that ART ensures regional coordination is by maintaining strong working relationships with its partners. As part of its vision for enhancing mobility in the region, ART consistently coordinates with FDOT and partners with GoLine and The Marty to connect riders to Indian River and Martin counties, respectively. Furthermore, a new express route connecting Port St. Lucie to West Palm Beach is anticipated to start operating soon, expanding ART's regional coordination to Palm Tran.

Implications

Partnerships with GoLine, The Marty, Palm Tran, and FDOT are crucial to improving regional travel by transit. As the public and visitors to the region want connectivity, it is imperative for ART to maintain strong regional partnerships to ensure easy movement between systems.

Furthermore, with 13% of Route 1's revenue miles operating in Martin County, ART should explore the possibility of financial contributions by Martin County to improving frequencies on Route 1, as it is estimated that more than 27,000 commuters travel to and from St. Lucie and Martin counties daily. Also, Okeechobee County is another common destination/origin for daily commuters not served by ART. While a regular service may not be feasible at this time due to the distance and comparatively low demand, ART should continue to monitor future opportunities.

Section 6. Goals and Objectives

This section summarizes the transit goals and objectives for the *Reimagine Transit* TDP, providing the policy direction to guide ART to achieve the community’s vision for transit over the next 10 years.

The *Reimagine Transit* goals and objectives were developed by updating the adopted TDP goals/objectives following a review and assessment of existing conditions, feedback received from the public involvement process, findings in the Situation Appraisal, and discussions with staff. The updated goals and objectives for the *Reimagine Transit* TDP are presented below.

Goal 1: Provide an effective, efficient, safe, and convenient public transit service that meets the mobility needs of the County.

Objective 1.1 Increase the number of one-way, fixed-route passenger trips by an average of 5% annually.

Strategy 1.1.1 Implement capital and service improvements and expansions consistent with the priorities identified in the *Reimagine Transit* TDP.

Strategy 1.1.2 Expand opportunities for regional travel, including express bus services, park-and-ride facility access, and feeder services for any potential regional rail connections.

Strategy 1.1.3 Meet at least once quarterly with regional partners, such as GoLine, The Marty, PalmTran, and FDOT, to coordinate on the pursuit and implementation of regional transit opportunities.

Strategy 1.1.4 Improve frequency on high performing routes to 30-minute headways or better.

Strategy 1.1.5 Expand weekday service hours and add weekend service based on transit demand.

Strategy 1.1.6 Expand app-based on-demand microtransit services in suitable areas utilizing vans or smaller bus vehicles.

Strategy 1.1.7 Develop the current route network to accommodate potential addition of a passenger rail station in St. Lucie County.

Objective 1.2 Maintain service reliability and on-time performance.

Strategy 1.2.1 Maintain state of good repair targets consistent with the Transit Asset Management (TAM) Plan for revenue vehicles.

Strategy 1.2.2 Ensure no less than 10,000 miles between roadcalls.

Strategy 1.2.3 Achieve on-time performance of 90% or better for fixed-route services.

Strategy 1.2.4: Operate a fixed-route fleet of vehicles with an average age of less than seven years.

Objective 1.3 Develop a system-wide performance monitoring program.

Strategy 1.3.1 Implement a performance monitoring program that provides a threshold for determining individual route performance and when improvements are to be considered.

Strategy 1.3.2 Evaluate and modify fixed-route bus service that falls below 75% of the system-wide average for passenger trips per revenue hour.

Strategy 1.3.3 Incorporate measures from the performance monitoring program and create quarterly reports on fixed-route and paratransit services.

Strategy 1.3.4 Integrate TAM targets and other desired standards into an overall performance monitoring program, adopted by the Board of County Commissioners.

Strategy 1.3.5: Track rider complaints and review quarterly.

Objective 1.4 Form partnerships with public and private entities to develop innovative services and technology programs and pilot projects.

Strategy 1.4.1 Identify and engage at least two potential public and private partners annually.

Strategy 1.4.2 Develop at least one action plan annually with identified partners to pursue and identify potential micro-transit pilot projects and possible funding sources. Pursue and implement at least one additional pilot project by FY 2027.

Strategy 1.4.3 Develop at least one action plan annually with identified partners to pursue and identify potential alternative fuel vehicle applications, best practices, and possible grant resources.

Strategy 1.4.4 Coordinate with FDOT and South Florida Commuter Services to identify and approach major employers and initiate employee commuter programs, introduce new routes, and/or other commute options to improve access to current and emerging jobs.

Strategy 1.4.5: Explore the possibility of implementing and/or expanding autonomous vehicle transit in Tradition and/or other applicable such areas.

Objective 1.5 Improve accessibility to transit services and facilities.

Strategy 1.5.1 Work with St. Lucie County and its municipalities to develop an inventory of sidewalks and gaps within a ½ mile of each bus stop, outlining a transit-related accessible path needs plan by FY 2026.

Strategy 1.5.2 Enhance sidewalk development and accessibility to bus stops and transit stations by annually identifying gaps in accessible paths and working with the TPO, School

Board, and other local jurisdictions to incorporate accessibility into their project evaluation and prioritization process for funding.

Strategy 1.5.3 Systematically improve infrastructure including benches, shelters, signage, and overall accessibility at bus stops by utilizing the Transit Facility Needs and ADA Transition Plan; update the Transition Plan no less than every three years.

Strategy 1.5.4 By FY 2027, integrate the Transit Facility Needs and ADA Transition Plan into the development review process to ensure that developers are contributing to the funding of vital transit infrastructure and accessibility.

Goal 2: Offer financially-efficient and affordable transit services.

Objective 2.1 Maintain cost efficiencies and financial stability.

Strategy 2.1.1 Maintain funding levels for fixed-route bus service consistent with the *Reimagine Transit TDP*-financial plan.

Strategy 2.1.2 Implement efficiency improvements and operational adjustments that will prevent an increase in operating costs per revenue mile of more than 5% annually.

Objective 2.2 Identify and evaluate additional opportunities to enhance revenues.

Strategy 2.2.1 Submit annually, at a minimum, three grant applications/requests for capital and/or operating funding available through federal, state, and local grant programs.

Strategy 2.2.2 Meet annually with the St. Lucie County Planning Division to jointly develop improved and/or development regulations that support increased contributions from developers for transit facilities or new services.

Strategy 2.2.3 Periodically, but not less than annually, review the new or emerging developments for private/partner contributions to support enhanced or new transit services.

Goal 3: Enhance visibility of ART in the community through marketing and education efforts.

Objective 3.1 Achieve regional and local support of transit initiatives.

Strategy 3.1.1 Reach out to at least three major employers and institutions annually to assess marketing and educational opportunities and develop partnerships for implementation of enhanced public transportation services.

Strategy 3.1.2 Develop and maintain a contact database and distribution list for use in notifying customers and potential customers about system improvements and changes.

Strategy 3.1.3 Develop an action plan and a series of public awareness resources that describe the benefits of transit service and outline transit as an attractive and cost-effective travel option.

Strategy 3.1.4 Implement the action plan to increase public awareness of the benefits of transit service by marketing transit as an attractive and cost-effective travel option, reviewing the effectiveness and updating at least annually.

Strategy 3.1.5 Communicate through newsletter or presentation to at least 10 audiences, including governmental bodies, community groups, transit passengers, neighboring transit agencies, on the state of transit in St. Lucie County on an annual basis.

Objective 3.2 Implement a marketing plan.

Strategy 3.2.1 Annually review schedules and rider information to ensure they are easily accessible to customers.

Strategy 3.2.2 Annually review and update the marketing plan.

Strategy 3.2.3 Annually implement the marketing plan and pursue advertisement opportunities; develop marketing resources and materials as outlined in the plan.

Strategy 3.2.4 Annually review and update electronic communications (web site, social media, etc.) to ensure user-friendly formats.

Strategy 3.2.5 Coordinate marketing strategies outlined in the marketing plan with the South Florida Commuter Services program on targeting commuters within and commuting to and from St. Lucie County.

Strategy 3.2.6: Utilize transit branding strategies that strengthen brand identity, aligning with transit agency and County goals and initiatives.

Objective 3.3 - Support and participate in local and regional economic development and transportation planning efforts.

Strategy 3.3.1: Continue developing local partnerships to ensure long-term viability of public transportation options in St. Lucie County.

Strategy 3.3.2: Coordinate with other County Departments including Community Development, Planning and Development Services, Veteran Services, Parks and Recreation, and Visitor and Convention Bureau to align strategies and advance efforts that support transit.

Goal 4: Promote transit supportive land use and policies.

Objective 4.1 Review/update local development codes to enhance the ability to fund and develop new transit options in growing areas.

Strategy 4.1.1 Meet at least annually with appropriate County departments and the municipal jurisdictions to identify strategies that will encourage and foster the development community to provide/build transit-supportive development.

Strategy 4.1.2 Coordinate with the St. Lucie County Planning Department to support the use of development incentives for developers and major employers to support and promote public transportation.

Strategy 4.1.3 Meet annually with local municipalities to develop, approve, and support the use of development incentives for developers and major employers to support and promote public transportation.

Strategy 4.1.4 Coordinate with County departments to encourage a mix of residential, commercial, higher-density development around transit nodes and corridors.

Goal 5: Minimize the environmental impacts of public transportation and advocate for sustainable community values.

Objective 5.1 – Reduce ART’s carbon footprint and fuel costs.

Strategy 5.1.1: Investigate converting transit fleet to no/low emission alternative fuel bus vehicles as existing vehicles reach their useful life benchmark.

Strategy 5.1.2: Evaluate the fuel and maintenance cost of the existing fleet and compare to projected costs of no/low emission alternative fuel vehicle capital and maintenance cost.

Strategy 5.1.3: Explore federal grants to fund fleet replacement with no/low emission alternative fuel vehicle, such as electric vehicles.

Objective 5.2 - Evaluate bicycle storage at major transfer centers/park-and-ride facilities and ensure all bicycle racks on buses are able to carry the maximum capacity.

Strategy 5.2.1: Implement a policy to allow foldable bicycles on board or allow all bicycles on board if the vehicle is at less than 50% capacity.

Strategy 5.2.3: Evaluate bicycle storage capacity at all ART stops annually and consider implementing secured covered bicycle storage at major transfer stations.

Section 7. Transit Demand and Accessibility Assessment

This section summarizes transit demand and accessibility assessments conducted to understand existing and potential travel needs locally and regionally. These types of latent demand assessments are a key component of TDPs and, when combined with the initial analyses and outreach, serve as building blocks for identifying the community’s transit needs. This section summarizes the demand and mobility needs assessment conducted as part of the *Reimagine Transit* 10-year TDP.

The following assessment techniques were used, as described below.

- **Transit Market Assessments** – Two market assessment tools were used to assess demand for transit services for the next 10 years. The tools assessed traditional and discretionary transit user markets in St. Lucie County for the TDP Major Update.
- **Existing Transit Accessibility Analysis** – A transit accessibility assessment was conducted using existing transit data and software tools to understand ART’s existing coverage and accessibility gaps compared to potential coverage needs locally and regionally.
- **Ridership Demand Assessment** – Projected ridership demand for the existing transit network was analyzed to gauge route level and systemwide demand to maintain the current transit service levels and facilities. The fixed-route projections were prepared using the Transit Boardings Estimation and Simulation Tool (TBEST), the FDOT-approved ridership estimation software for TDPs.

Transit Market Assessment

Two GIS-based tools were utilized to expand the analysis of population and employment data, summarized previously in this TDP. The Density Threshold Assessment (DTA) supplements these findings by illustrating the relationship between the discretionary market and the use of transit as a commuting alternative. The Transit Orientation Index (TOI) measures levels of traditional rider markets, such as older adults, youth, and low-income/no vehicle households, compared to existing transit coverage to gauge propensity for transit use.

Discretionary Rider Markets

The discretionary market includes potential riders living and/or working in higher-density areas who may choose to use transit as a commuting or transportation alternative. A DTA was conducted using industry-standard density thresholds to identify areas within the county that exhibit transit-supportive residential and employee density levels both today and in the future. Socioeconomic data for the study area, including dwelling unit and employment data developed for the regional travel demand model, were used to conduct the DTA.

Density Threshold Assessment Methodology

Regionally-developed socioeconomic data, including dwelling unit and employment data at the Traffic Analysis Zone (TAZ) level, were obtained. Using these data variables through a process of linear interpolation using 2015 and 2045 data points from LRTP data, existing (2025) and future (2034) dwelling unit and employment data were derived and analyzed.

Three density thresholds based on industry standards/research were used to identify areas characterized by density levels able to sustain some level of fixed-route transit operations:

- Minimum Investment – reflects minimum dwelling unit or employment densities to support basic fixed-route transit services (i.e., local fixed-route bus service).
- High Investment – reflects increased dwelling unit or employment densities that may support higher levels of transit investment (i.e., more frequent service, longer service span, etc.).
- Very High Investment – reflects very high dwelling unit or employment densities that may support more significant levels of transit investment (i.e., very frequent services, later service hours, weekend service, premium modes, etc.).

Table 7-1 presents the dwelling unit and employment density thresholds associated with each level of transit investment.

Table 7-1: DTA Density Thresholds

Level of Transit Investment	Dwelling Unit Density Minimum /Threshold ¹	Employment Density Minimum/Threshold ²
Minimum Investment	4.5–5 dwelling units/acre	4 employees/acre
High Investment	6–7 dwelling units/acre	5–6 employees/acre
Very High Investment	≥8 dwelling units/acre	≥7 employees/acre

¹ TRB, National Research Council, TCRP Report 16, Volume 1 (1996), “Transit and Land Use Form,” November 2002, MTC Resolution 3434 TOD Policy for Regional Transit Expansion Projects.

² Based on review of research on relationship between transit technology and employment densities.

Maps 7-1 and 7-2 illustrate the 2025 and 2034 DTA analyses conducted for St. Lucie County, identifying areas that support different levels of transit investment based on existing and future dwelling unit and employment densities. These maps also include an overlay of the existing ART route network to gauge how well the current transit network covers the areas considered supportive of at least a minimum level of transit investment. As density increases, areas generally become more transit-supportive; the DTA assists in determining the presence of optimal conditions for varying levels of fixed-route transit service. The results of these analyses also will be critical for subsequent use in the assessment of transit needs and demand.

DTA Summary of Findings

The 2025 DTA analysis indicates that the discretionary transit markets are derived mainly from employment densities rather than from dwelling unit densities and can be summarized as follows:

- Minimum employment densities are located throughout the eastern part of the county, primarily located along major corridors such as US 1, I-95, Port St. Lucie Boulevard, and St. Lucie West Boulevard.
- Most areas with minimum dwelling unit densities are located in central Fort Pierce, along major corridors in Port St. Lucie, and Hutchison Island South.
- All areas considered to meet the “high” or “very high” employment thresholds for transit investment are located:
 - On St. Lucie Boulevard along N 25th Street.
 - Along US 1 between St. Lucie Boulevard and Port St. Lucie Boulevard.
 - Along St. Lucie West Boulevard between I-95 and Florida Turnpike.
 - Between St. Lucie West Boulevard and Port St. Lucie Boulevard along the Florida Turnpike, along Port St. Lucie Boulevard adjacent to I-95, and adjacent to Okeechobee Road east of the Florida Turnpike.
- Most areas that meet at least the minimum DTA thresholds are currently served by ART.
- Based on the 2034 DTA analysis, all areas in the 2025 DTA that meet the “high” or “very high” thresholds for dwelling units and/or employment will remain. Some new areas that meet the “minimum” requirement will be adjacent to established areas as follows:
 - Between I-95 and Glades Cutoff Road along Midway Road.
 - West of A1A on Hutchison Island.

Map 7-1: DTA / 2025

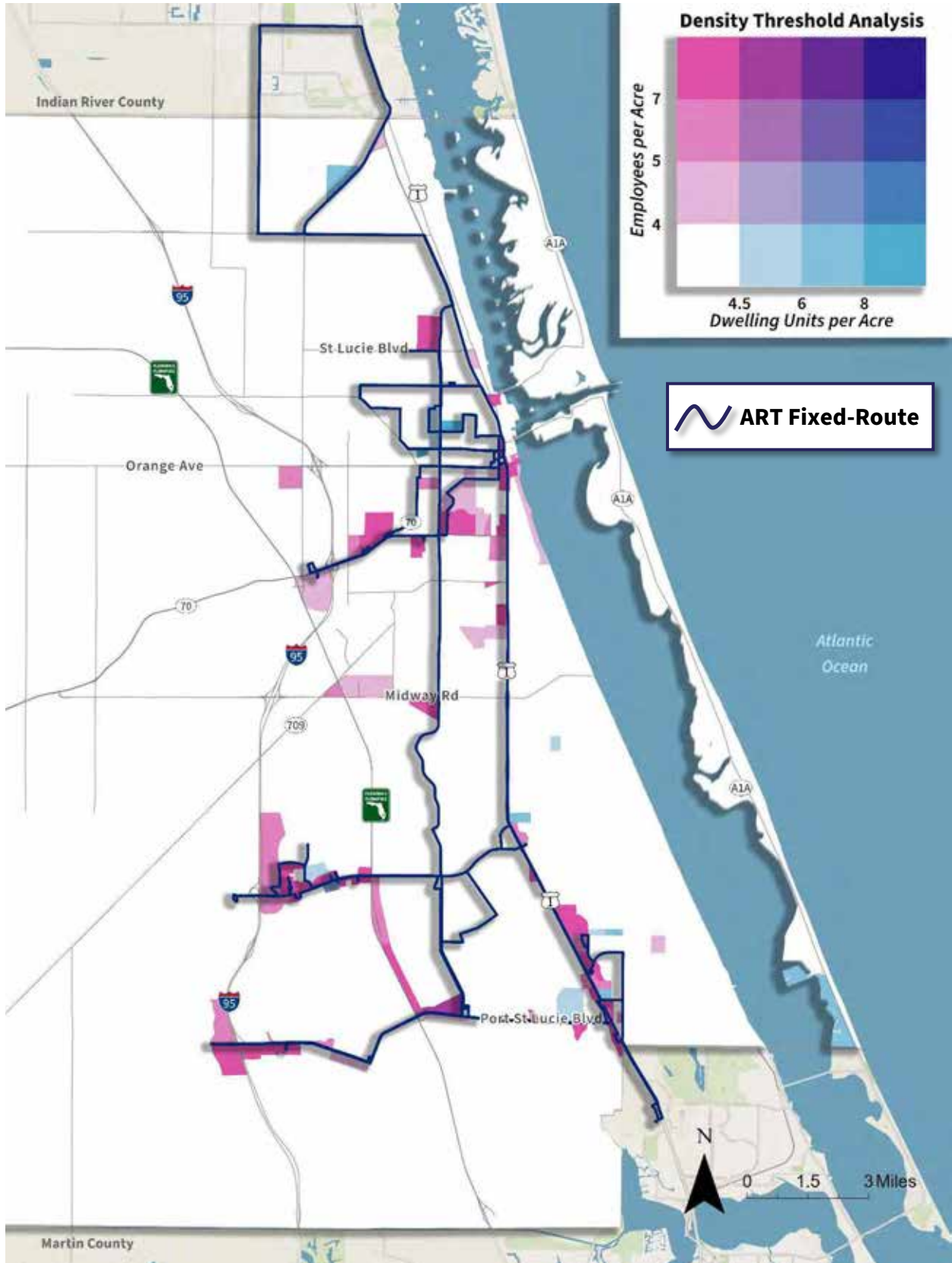

Map 7-2: DTA | 2034

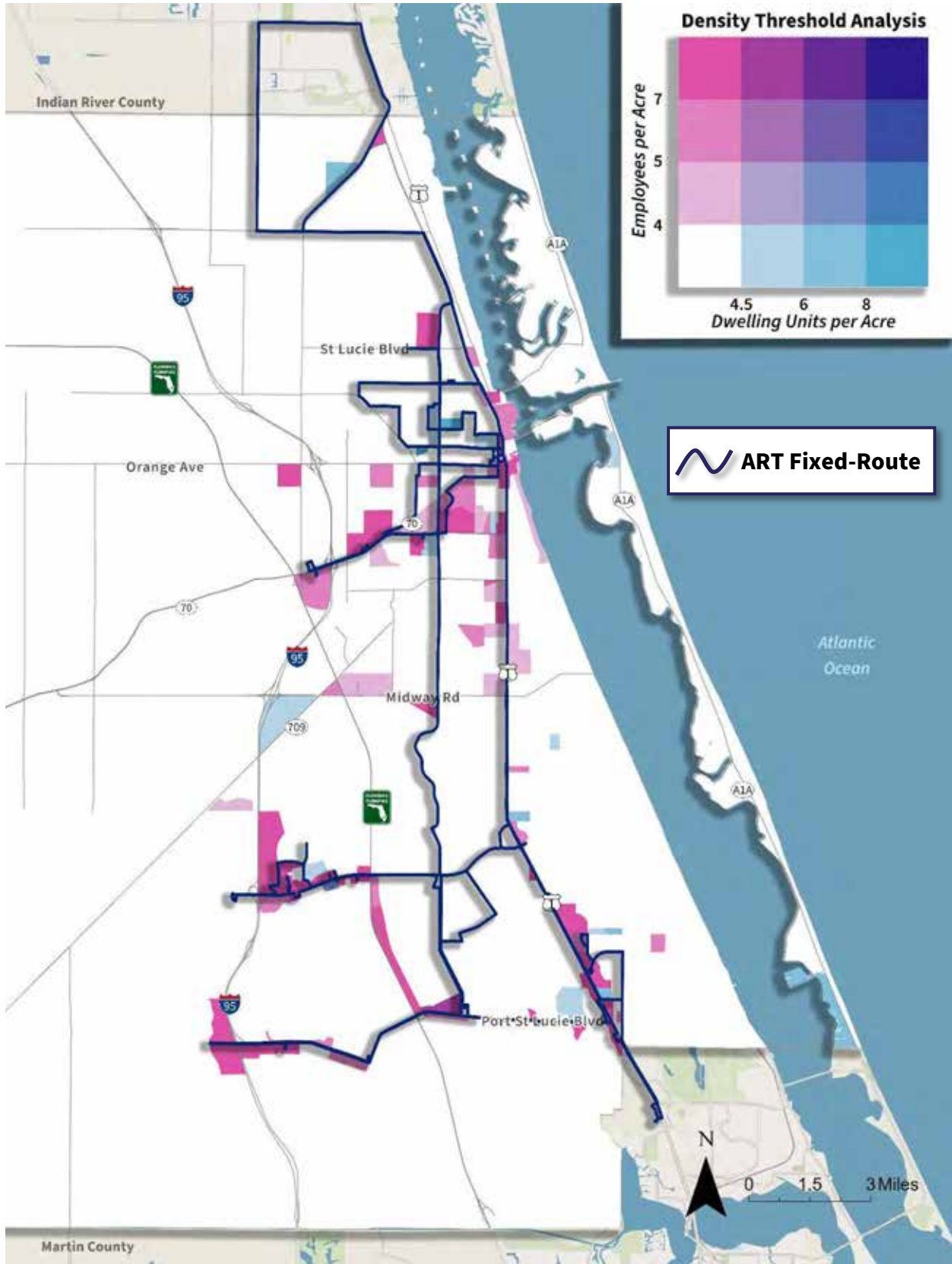

Traditional Rider Markets

The traditional rider market includes population segments that historically have a higher propensity to use or are dependent on public transit for their transportation needs. For some individuals, the ability to drive is greatly diminished with age and they must rely on others for transportation. Younger people may not have a driver’s license or car, or may be more open to using transit to reach work, school, and recreational activities than prior generations. For lower-income households, transportation costs can be burdensome, as a greater proportion of income is used for transportation-related expenses compared to higher-income households. Households with restricted income may have less vehicle access and be more likely to rely on public transportation.

The TOI assists in identifying residential areas of the county where traditional rider markets exist defined as:

- Youths – persons aged 15 to 24
- Low-income households—households that meet the federal poverty definition
- Zero-vehicle households
- Older adults – persons age 65 and over

Transit Orientation Index Development Methodology

To create the TOI for this analysis, demographic data from the 2023 American Community Survey (ACS) 5-Year Estimates (2017–2021) were analyzed at the block group level for the selected demographic variables. Census block groups representing the study area were selected, and the percentage distributions for each demographic characteristic previously identified were compiled for each. These proportions were then ranked in descending order. Using the TOI methodology, an average proportion and standard deviation for each demographic characteristic was computed. A standard deviation measures the extent to which the actual percent values for each block group vary from the average. With a normal “bell-shaped” distribution, approximately 68% of the values will be within 1 standard deviation of the average percent and 95% will be within 2 standard deviations of the average. The proportions were stratified into three segments—average percent, average percent plus 1 standard deviation, and average percent plus 2 standard deviations.

The resulting values for each block group were placed into one of four categories for each demographic characteristic—Below Average (“Low”), Above Average but within 1 Standard Deviation (“Medium”), Above Average but between 1 and 2 Standard Deviations (“High”), and Above Average but more than 2 Standard Deviations (“Very High”). The scores were assigned using a comparative probability distribution methodology by first estimating the probability that a block group would be within a given category for a given demographic characteristic.

Individual category scores were summed to obtain a composite score for each block group, and the block groups were ranked by composite score. Block groups with the highest scores were indicated as having a “Very High” orientation for transit use based on the four demographic characteristics. Other categories were indicated as having “High,” “Medium,” and “Low” orientations, respectively. Using

this composite ranking, each study area Census block group was ranked as “Very High,” “High,” “Medium,” or “Low” in their levels of transit orientation.

Understanding the corresponding population density is important when considering transit service for a block group with orientation towards transit. If a block group has a high orientation towards transit but is very low in population density, it may be more difficult to serve riders compared to an area that is both very highly oriented towards transit and highly dense in population. As a result, TOI categories were cross-tabulated with area density to maximize the effectiveness of the TOI developed for the study area. In addition, a “Very Low” TOI category was created to identify the lowest-density areas from this analysis.

Figure 7-1: TOI Methodology

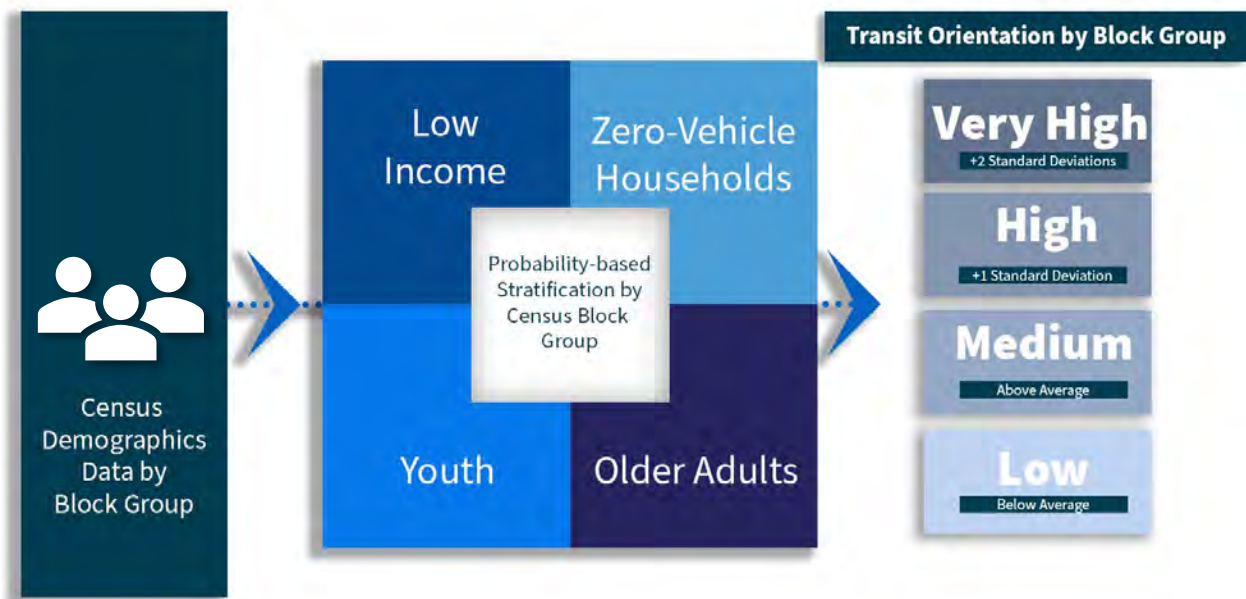

Map 7-3 illustrates the 2023 TOI in terms of population density, reflecting areas throughout St. Lucie County with varying traditional market potential.

Map 7-3: TOI | 2023

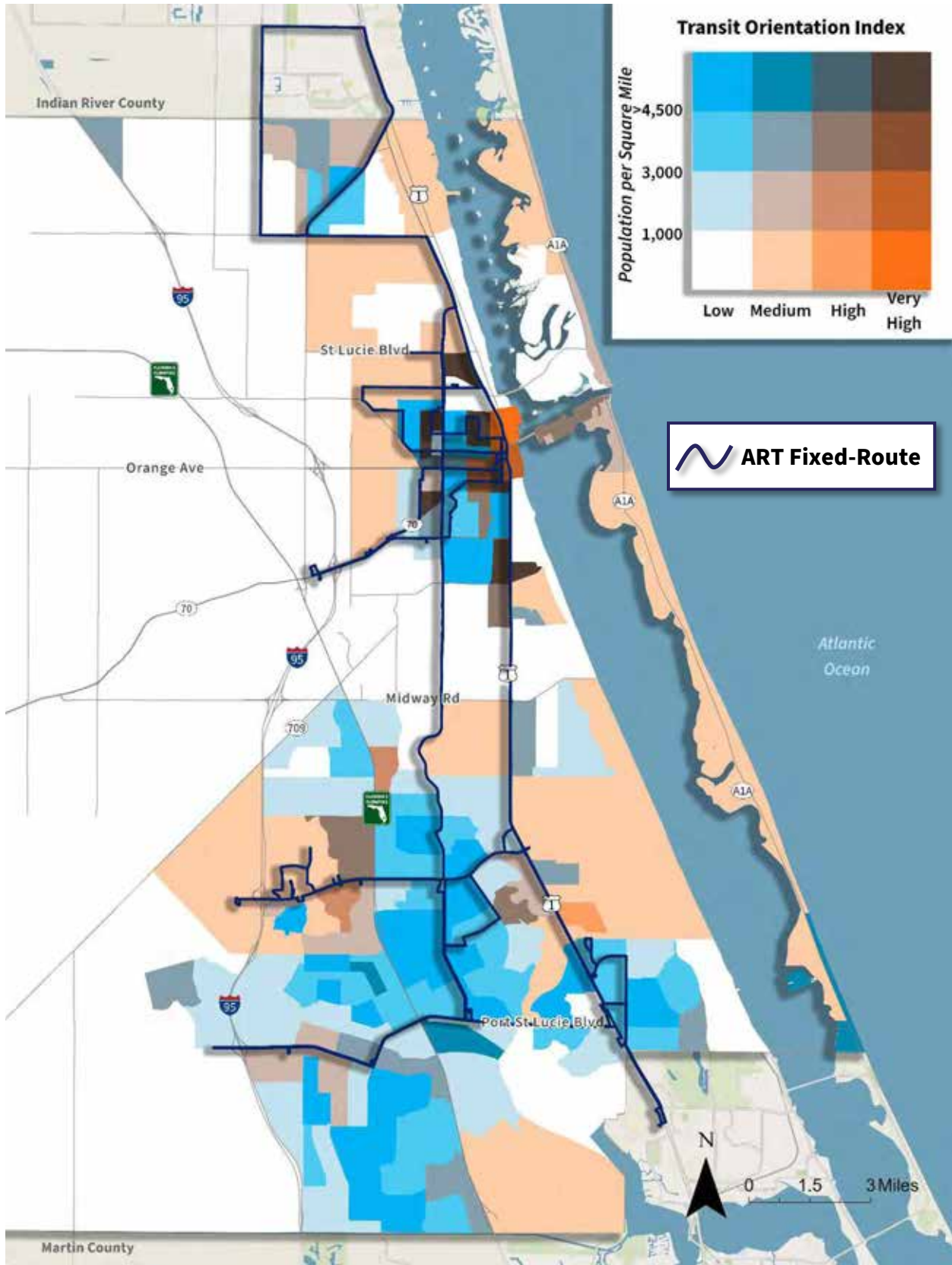

Traditional Market Summary

Results from the TOI analysis are as follows:

- All areas considered to meet the “high” or “very high” TOI thresholds for transit investment are in the following areas:
 - In and surrounding downtown Fort Pierce
 - Hutchinson Island
 - Near Oleander Boulevard and US 1 south of Virginia Avenue
 - A few tracts in St. Lucie West
 - Near US 1 and Crosstown Parkway
- Most tracts with both high population densities and “high” or “very high” TOI scores are in central Fort Pierce, Port St. Lucie west of US 1, and south of St. Lucie West Boulevard.

Existing Transit Accessibility Analysis

An analysis also was conducted to identify the degree of accessibility from key transfer hubs via the current ART fixed-route system. The extent to which a given major transfer hub, which typically is located at a major destination, is accessible via transit can provide valuable information on how the current system may impact travel patterns of current and potential riders. The Fort Pierce Intermodal Center and the Port St. Lucie Intermodal Center were selected for the analysis.

Using service area data and functionalities from FDOT’s TBEST, a travel time analysis for current and potential ART users was conducted. For these locations, accessibility was measured in the morning peak travel period with a ¼-mile walk access to transit. It is important to note that the total travel time in this analysis not only includes time on-board the bus, but also wait time at the bus stop (maximum of 15 minutes); transfers to another bus (if applicable), and walk time from the final bus stop to the transit center as illustrated in Figure 7-2.

The accessibility/travel patterns analysis results are shown in Maps 7-4 and 7-5. The maps include the existing route network and key interstates and roadways. Areas not colored according to the legend are beyond the 90-minute travel time shed or are not populated areas.

Figure 7-2: Components of the 90-Minute Bus Trip

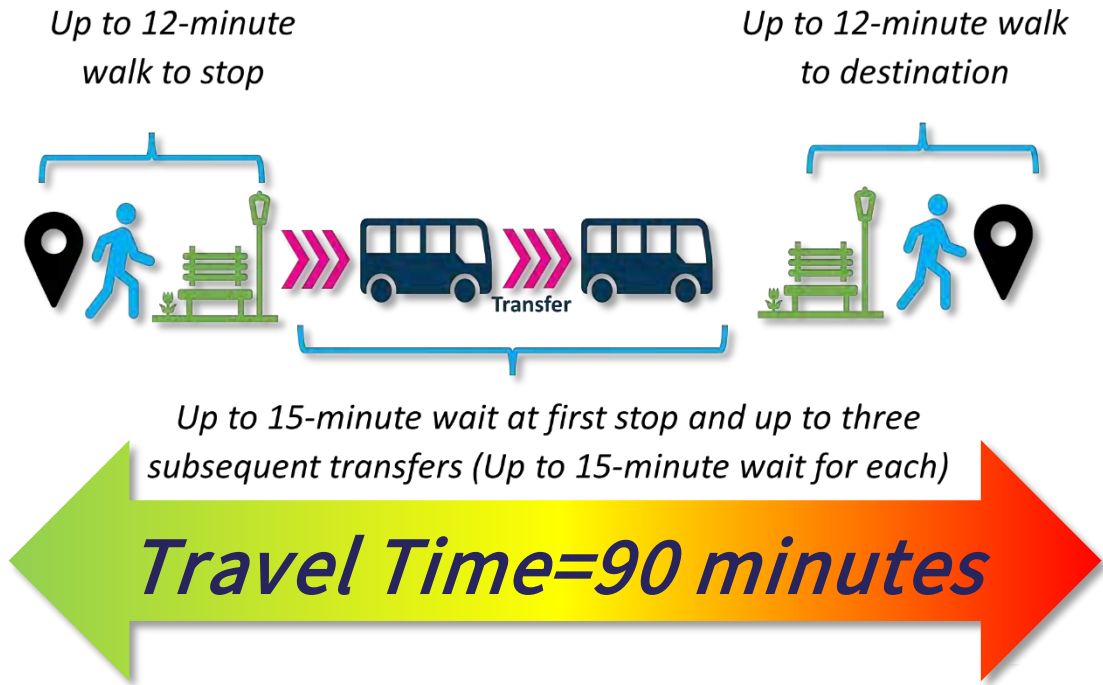

Map 7-4: Fort Pierce Intermodal Center Accessibility

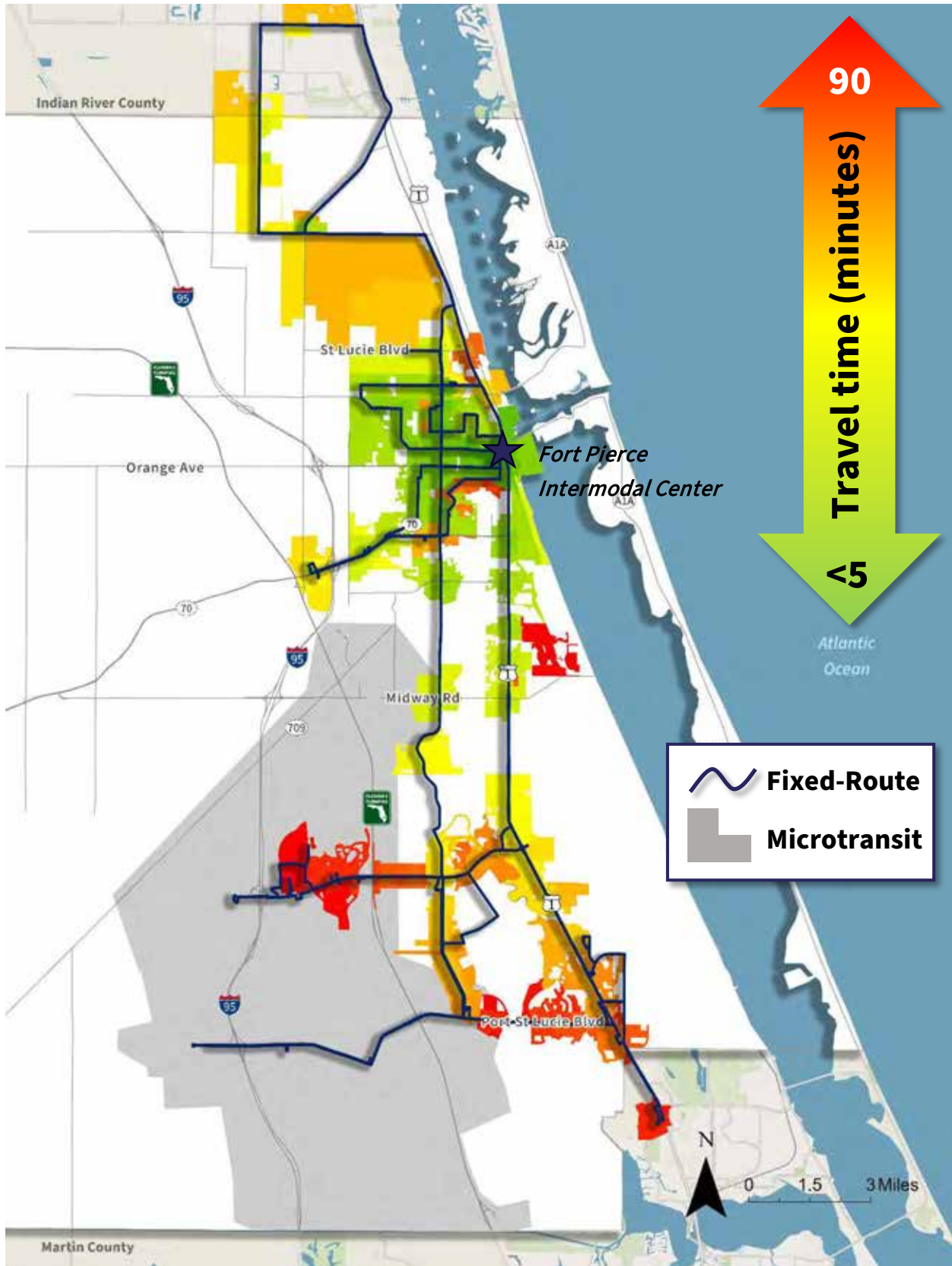

Map 7-5: Port St. Lucie Intermodal Center Accessibility

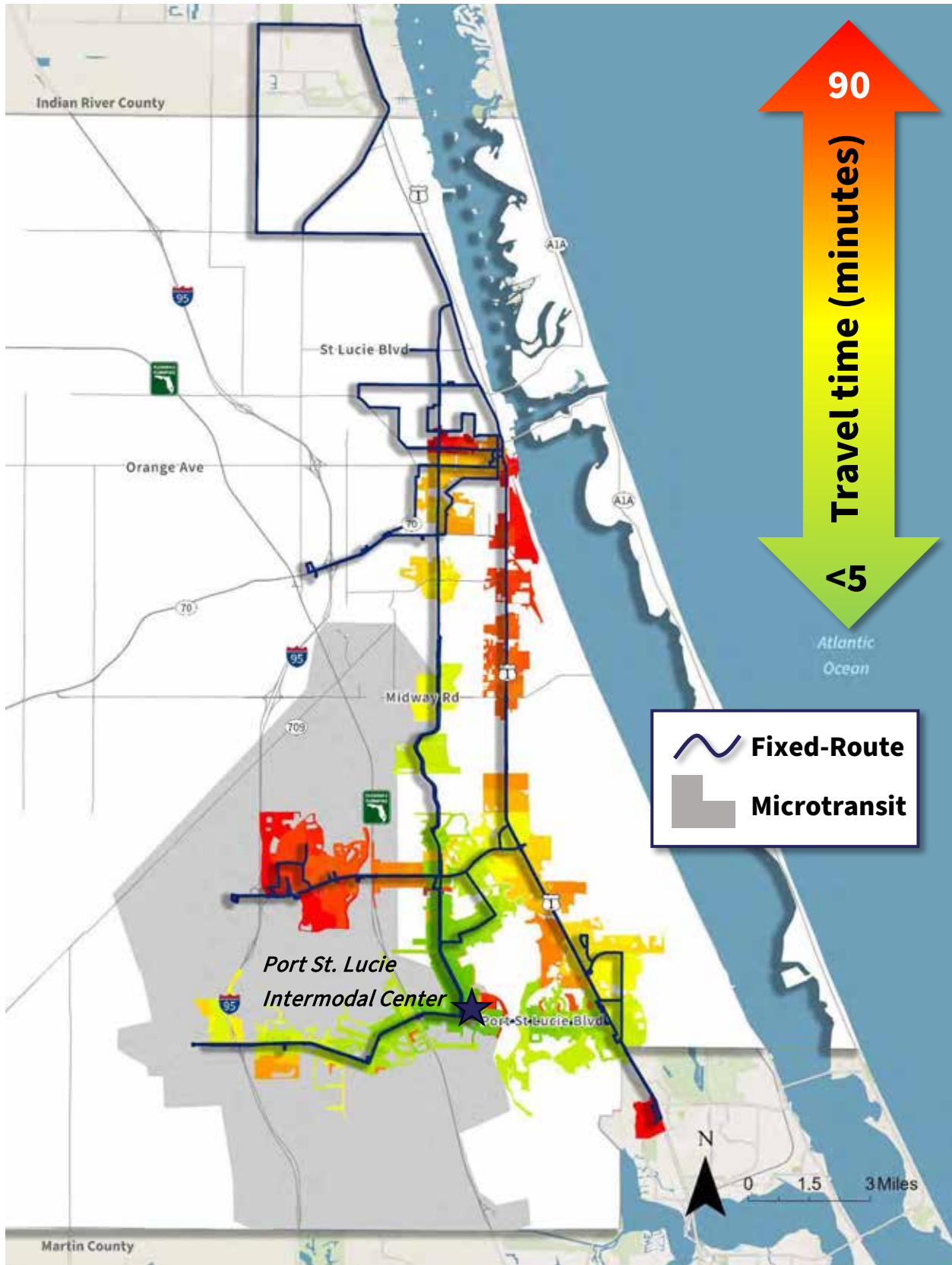

Fort Pierce Intermodal Center

The Fort Pierce Intermodal Center is located at Avenue D and N 8th Street, just northwest of downtown Fort Pierce. Routes 1, 2, 3, 7, and 8 serve the Fort Pierce Intermodal Center and most areas in Fort Pierce are quickly accessible. Riders can also access Port St. Lucie via US 1 and S 25th Street. More than 85,200 residents live and 39,400 jobs are within a 90-minute transit ride from the Fort Pierce Intermodal Center.

Port St. Lucie Intermodal Center

The Port St. Lucie Intermodal Center is located at SE Thanksgiving Avenue and SE Belvedere Street, just north of Port St. Lucie Boulevard and adjacent to the city’s municipal complex and community center. Routes 4, 5, 6, and 8 serve the Port St. Lucie Intermodal Center and it is most directly accessible from most areas in Port St. Lucie. Service reaches Fort Pierce via Airoso Boulevard and St. James Drive. Approximately 84,000 residents in these areas live within a 90-minute transit ride from the Port St. Lucie Intermodal Center. Furthermore, this transit hub provides access to more than 32,300 jobs within a 90-minute transit ride.

Ridership Demand Assessment

As another component of the transit demand assessment, forecasted transit ridership for the existing and proposed fixed-route transit networks were analyzed using TBEST, the FDOT-approved ridership estimation software for TDPs. This analysis gauges the route-level and system-wide demand, assuming both maintaining existing transit services and implementing the needed improvements identified in the TDP.

TBEST is a comprehensive transit analysis and ridership-forecasting model that can simulate travel demand at the individual route level. The software was designed to provide near- and mid-term forecasts of transit ridership consistent with the needs of transit operational planning and TDP development. In producing model outputs, TBEST also considers the following:

- **Transit Network Connectivity** – The level of connectivity between routes within a bus network; the greater the connectivity between bus routes, the more efficient the bus service becomes.
- **Spatial and Temporal Accessibility** – Service frequency and distance between stops; the larger the physical distance between potential bus riders and bus stops, the lower the level of service utilization. Similarly, less frequent service is perceived as less reliable and, in turn, utilization decreases.
- **Time-of-Day Variations** – Peak-period travel patterns are accommodated by rewarding peak service periods with greater service utilization forecasts.
- **Route Competition and Route Complementarities** – Competition between routes is considered. Routes connecting to the same destinations or anchor points or that travel on common corridors experience decreases in service utilization. Conversely, routes that are synchronized and support each other in terms of service to major destinations or transfer locations and schedule benefit from that complementary relationship.

The following sections outline the model input and assumptions, describe the TBEST scenarios performed, and summarize the ridership forecasts produced by TBEST.

Model Inputs / Assumptions and Limitations

TBEST uses various demographic and transit network data as model inputs. This analysis used the recently-released TBEST Land Use Model structure (TBEST Land Use Model 2023), which is supported by parcel-level data from the Florida Department of Revenue (DOR) statewide tax database. The DOR parcel data contain land use designations and supporting attributes that allow the application of Institute of Transportation Engineers (ITE)-based trip generation rates at the parcel level as an indicator of travel activity.

It should be noted, however, that the model is not interactive with roadway network conditions. Therefore, ridership forecasts will not show direct sensitivity to changes in roadway traffic conditions, speeds, or roadway connectivity.

Transit Network

The transit route network for all existing ART routes was created to reflect 2023 conditions, the validation year for the model. General Transit Feed Specification (GTFS) data as of September 2023 were obtained from ART to provide the input for the base transit system. Data include:

- Route alignments
- Route patterns
- Bus stop locations
- Service spans
- Existing headways during peak and off-peak periods (frequency at which a bus arrives at a stop—e.g., 1 bus every 60 minutes)

The GTFS data were verified to ensure the most recent bus service spans and headways; edits were made as needed. Transfer locations were manually coded in the network properties.

Socioeconomic Data

To gain consistency with local existing and projected socioeconomic conditions, updated zonal population and employment totals derived from the St. Lucie TPO’s 2045 Long Range Transportation Plan (LRTP) were used. TBEST identifies spatial intersection between the zonal data and the Census block group geometry of the region to calculate growth rates by Census block group. Once calculated, the Census block group growth rates are stored within TBEST and applied when using all TBEST analysis engines. Using the data inputs listed above, the model captures market demand (population, demographics, employment, and land use characteristics) within ¼-mile of each stop.

Population and employment data are hard-coded into the model and cannot be modified by end-users. As applied, the growth rates do not reflect fluctuating economic conditions experienced in real time.

Special Generators

Special generators were identified and coded into TBEST to evaluate the opportunity for generating high ridership. ART special generators include the following:

- University – IRSC Massey Campus and IRSC Pruitt Campus
- Transfer Hub – Fort Pierce Intermodal Facility, Port St. Lucie Intermodal Facility, Jobs Express Park and Ride, Treasure Coast Mall (Martin County), and Intergenerational Recreation Center (Indian River County)
- Park-and-Ride – Fort Pierce Intermodal Facility, Port St. Lucie Intermodal Facility, and Jobs Express Park and Ride
- Shopping Mall – Treasure Coast Mall (Martin County), Tradition Village Center, and Town Center at St. Lucie West
- Event Center - MidFlorida Credit Union Event Center
- Hospital – HCA Florida St. Lucie Hospital, HCA Florida Lawnwood Hospital, and Cleveland Clinic Tradition Hospital
- Airport – Treasure Coast International Airport

TBEST Model Limitations

TBEST is an important tool for evaluating improvements to existing and future transit services; however, model outputs do not account for latent transit demand that could yield significantly higher ridership. In addition, TBEST cannot display sensitivities to external factors such as an improved marketing and advertising program, fuel prices, parking supply, walkability, and other local conditions so model outputs may over-estimate demand in isolated cases.

Although TBEST provides ridership projections at the route and bus stop levels, its strength lies more in its ability to facilitate relative comparisons of ridership productivity for evaluation in actual service implementation decisions. Therefore, it is important for ART to integrate sound planning judgment and experience when interpreting TBEST results.

Microtransit Ridership Estimation

There are few methods to estimate ridership demand for on-demand service. In 2016, the National Center for Transit Research (NCTR) published *Estimating Ridership of Rural Demand-Response Transit Services* documenting the use of NTD data from agencies across the US to calibrate on-demand ridership estimation. Like TBEST, this model may not capture nuanced local factors that influence on-demand service, but rather estimates potential demand based on common factors across service providers.

The model examines the impact of traditional transit markets on ridership and assumes that ridership can be estimated through total population, percentage of the population over age 65, percentage of households without access to a vehicle, agency operation of fixed-route services in addition to on-demand service, operation of services within a municipality, fare cost, and the location of the transit agency within a certain FTA region.

Ridership Forecast

Using these inputs, assumptions, and route level ridership data obtained from ART, the TBEST model was validated for the year 2023. Using the validation model as the base 2023 model, the following model scenarios and fixed-route ridership forecasts were developed for this TDP major update:

- 2025 Status Quo Scenario - Assumes the current network continuing in 2025.
- 2034 Status Quo Scenario - Assumes no TDP improvements are implemented and the current level of service is maintained in the next 10 years.
- 2034 TDP Scenario - Assumes TDP improvements are implemented.

The TBEST forecast for ART’s fixed-route system was supplemented with the microtransit ridership estimation using the NCTR methodology. Table 7-2 shows the overall forecast ridership for the 2025 and 2034 Status Quo and TDP scenarios. Additionally, it shows the percent change in ridership at the route and system levels for the Status Quo scenario from 2025 to 2034 and the potential growth by route from the Status Quo to TDP scenario in 2034.

Table 7-2: Ridership Projections / Status Quo and TDP Scenarios

Service	Route	Status Quo		TDP	Potential Change	
		2025	2034	2034	Status Quo (2025-2034)	2034 Potential Growth
Fixed-Route	1	198,893	249,461	414,409	25.4%	66.1%
	2	65,152	81,009	92,706	24.3%	14.4%
	3	88,095	109,385	165,045	24.2%	50.9%
	4	39,704	49,748	53,804	25.3%	8.2%
	5	24,985	30,722	N/A	23.0%	-
	6	45,115	55,214	N/A	22.4%	-
	7	24,909	31,245	36,965	25.4%	18.3%
	8	2,931	3,665	7,958	25.0%	117.1%
	Downtown/Passenger Rail/Beach Shuttle	N/A	N/A	112,625	-	-
	Dual Enrollment Shuttle	N/A	N/A	19,859	-	-
	Port St. Lucie Express	N/A	N/A	11,503	-	-
	Airport/College Express	N/A	N/A	42,252	-	-
	ART On Demand	North Port St. Lucie	34,669	49,259	57,409	42.1%
South Port St. Lucie		17,179	20,309	22,817	18.2%	12.3%
New North Fort Pierce		N/A	N/A	125,299	-	-
New South Fort Pierce		N/A	N/A	32,548	-	-
Total		541,632	680,017	1,195,199	25.5%	75.8%

Sources: TBEST for fixed-route ridership forecast; NCTR methodology for microtransit ridership forecast.

Section 8. Transit Needs Development

This section summarizes the development and evaluation of potential transit improvements for the *Reimagine Transit* TDP. The primary objective of this component is to leverage the data analysis and outreach completed thus far to develop potential service improvements and supporting capital projects to fulfill the unmet transit demand and mobility needs. Developed without consideration of funding constraints the proposed improvements, also referred to as alternatives, represent ART’s transit needs for the next 10 years.

The identified improvement needs will be prioritized using an evaluation process that considers public input and other qualitative and quantitative criteria, as discussed in this section. The resulting list of improvements will then be used to develop the 10-year implementation and financial plans for the TDP. Prioritized transit needs will assist in selecting and implementing service improvements as funding becomes available and as the demand for ART continues to grow.

Development of Transit Needs

The *Reimagine Transit* needs for the next 10 years in St Lucie County were developed through the following methods.

- *Community Direction and Vision* – Many public outreach techniques were used throughout the *Reimagine Transit* TDP planning process to obtain public input on desired vision and direction for public transportation and the corresponding needs. Surveys, public workshops, interviews with community stakeholders, riders, and even bus operators were held. In addition, small group discussion workshops with key stakeholders were also conducted to gather input from the local or regional leaders, elected officials, riders, and ART employees regarding the direction/vision for transit in the next 10 years.
- *Situation Appraisal* – Major updates to 10-year TDPs are required by State law to include an appraisal of the environment in which the transit agency operates. This unique assessment helps to better understand ART’s operating environment within the context of numerous key elements, as specified in the TDP Rule. The implications from the situation appraisal findings were considered in identifying potential transit alternatives.
- *Goals and Objectives* – Objectives and policies often provide insight into transit needs within the community and the potential means with which to meet them. ART’s TDP goals and objectives, updated as part of this effort, emphasize or enhance many of the broader community goals and support transit as a viable choice of travel and a practical option for residents and visitors in the next 10-years.
- *Transit Demand Assessment* – The assessment of transit demand and needs included the use of various GIS-based analyses, software tools, and methodologies to assess demographic data and land use patterns conducive to transit. These technical analyses,

together with the baseline conditions assessment and performance reviews previously conducted, were used to identify areas with transit-supportive characteristics when developing the list of transit alternatives.

10-Year Transit Needs

Based on these methods, transit needs were identified and grouped into three categories—service, capital, and technology/policy improvements. The specific improvements under each category developed for the *Reimagine Transit* TDP to meet the diverse travel needs in St. Lucie County are summarized below and illustrated on Map 8-1.

Service Needs

Service needs focus on expanding ART’s reach via various technology-based services and quick connections while also making the current system more efficient and useful. Improvements to address these needs include increasing route frequencies, expanding hours/days of service, and repurposing some routes to maximize usefulness to the community. The 10-year service needs also include service expansion improvements to add new routes or expanding premium transit options, such as app-based on-demand microtransit.

Enhance Existing Fixed-Route Bus Route Network

A review of baseline conditions, existing service performance data, and input from the public and bus operators indicated a need to streamline operations by repurposing and/or extending certain routes. This will optimize ART’s fixed-route network to better serve the community, enhance rider experience, and provide direct connections to key destinations.



Map 8-1: Reimagine Transit TDP 10-Year Needs

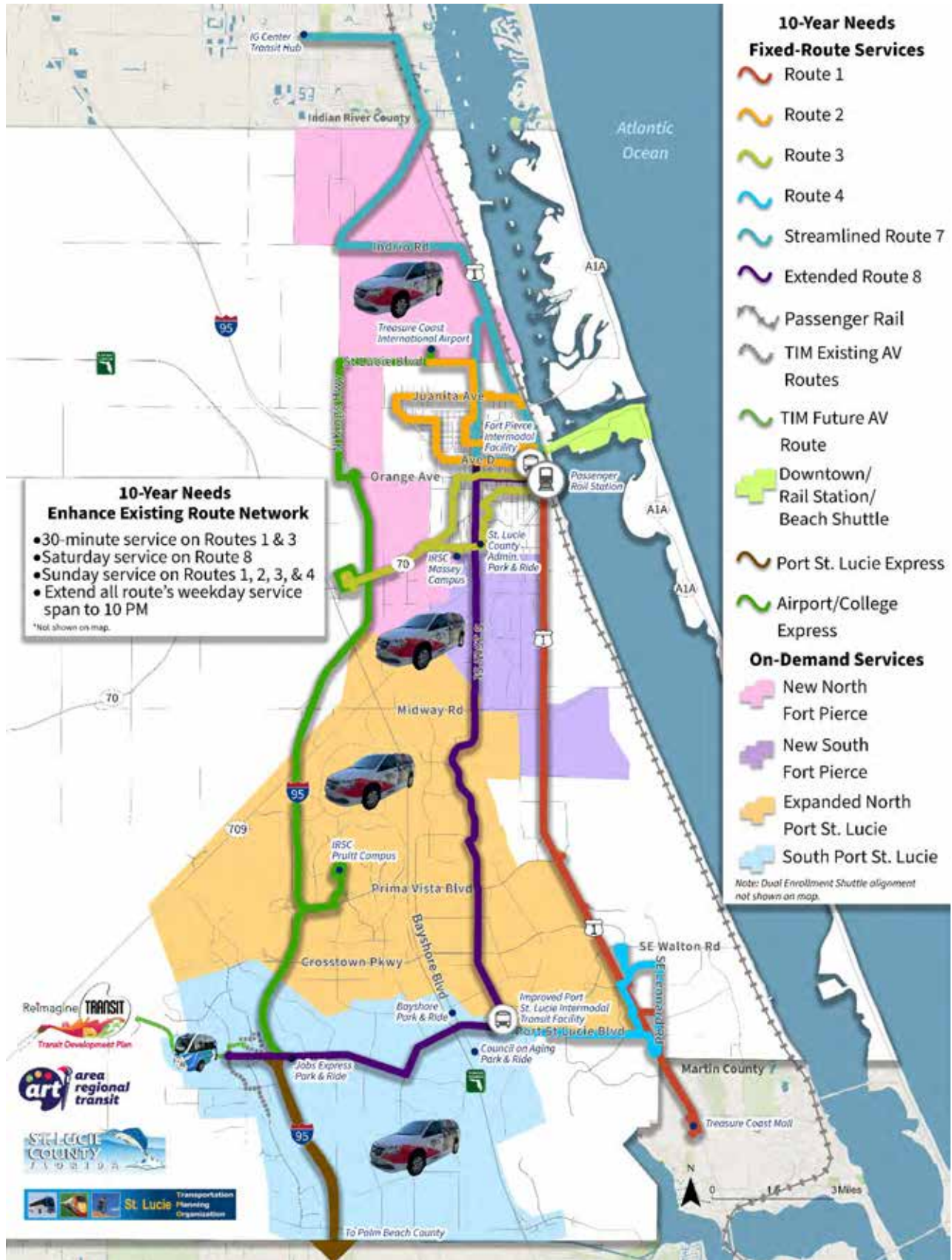

- **Streamline Route 7** – Realign Route 7 to operate only on 9th Street in Indian River County, US 1, Turnpike Feeder Road, and Indrio Road.
- **Repurpose Route 5** – Discontinue Route 5 and repurpose resources to extend Route 8.
- **Extended Route 8** – Extend Route 8 from the current terminus at Port St. Lucie Intermodal Center to the Tradition area to provide direct connections between Fort Pierce and Port St. Lucie, including the Tradition area and the new Jobs Express Park-and-Ride.
- **Repurpose Route 6** – Eliminate Route 6 and repurpose resources into expanding ART On Demand within that area.
- **Expand ART On Demand North** – Expand microtransit zone to cover the eliminated Route 6 service area.
- **Increase Frequency on Route 1 and Route 3** – Increase frequencies to 30 minutes on Routes 1 and 3 to support current demand and attract even more riders to these two best performing ART routes.
- **Add Saturday Service on Route 8** – With expanded Route 8 connecting to Tradition and other activity centers in Port St. Lucie, adding Saturday service would provide a direct weekend connection from Fort Pierce to these employment centers and to the former Route 5 service area.
- **Extend Service Span by Two Hours** – Extending hours of bus service until 10 PM on weekdays would increase the convenience of using transit to work or shopping trips.
- **Add Sunday Service on Routes 1, 2, 3, 4** – Add limited Sunday service on selected routes to provide seven day transit network access to key locations and corridors.

Add New Fixed-Route Services

As St. Lucie County’s population and employment continues to grow, the need for alternatives modes of transportation mobility options increases. Transit will also continue to be a potential remedy to mitigate worsening traffic congestion resulting from this continued growth. To provide increased network connectivity and expand service coverage, the following new services are recommended for the TDP.

- **Downtown/Rail Station/Beach Shuttle** – Input from the community and stakeholders indicated a need conveniently and quickly connect downtown Fort Pierce to key trip generators/hubs within and adjacent to it. This proposed new shuttle would connect the Fort Pierce downtown area to any future passenger rail station, the beaches on Hutchinson Island, and Fort Pierce Intermodal Center. This shuttle service will complement the current FreeBee service, adding another layer of quick and convenient travel option in Fort Pierce, operating all week every 15 minutes.
- **Port St. Lucie Express** – This regional connection to link Port St. Lucie to Palm Beach County and the PalmTran network via I-95 has already been planned. Regional travel flow data in combination with public input supports a transit connection to Palm Beach County, extending the reach of ART in the region. While the operating characteristics for this express route have

not been finalized, this TDP recommends weekday AM and PM peak hour service for the Port St. Lucie Express.

- **Airport/College Express** – With the anticipated growth, stakeholders and discussion group members indicated a need for transit to connect to the Treasure Coast International Airport. The Port St. Lucie/Airport Express would connect the Jobs Express Park-and-Ride and the Treasure Coast International Airport via I-95. The route would provide a quick north-south link, while connecting key cities, job centers, airport, and IRSC campuses. Additionally, the route will stop on Kings Highway and provide another connection to Fort Pierce via Route 3.
- **Dual Enrollment Shuttle** – This new shuttle service would connect selected high schools with IRSC Campus in St. Lucie County (and may include locations in Martin County with potential regional funding). The service is primarily focused on helping dual enrollment students travel between school and college campuses. This improvement is expected to be implemented as a pilot program using electric vehicles.
- **Establish Vanpool Program** – Currently there is no established vanpool program in St. Lucie County. ART should coordinate with South Florida Commuter Services to expand the current vanpool program to St. Lucie County.
- **Expanded Tradition in Motion (TIM) AV Connector** – This plan assumes the expansion of existing privately-funded AV service currently operating in Tradition. There are two planned routes to expand the autonomous network to new communities and job centers, potentially including Amazon, Cheney Brothers, and FedEx locations. This service connects to extended Route 8.

Expand On-Demand Microtransit Services

Microtransit service, branded as ART On Demand, has become a popular transit option in St. Lucie County since its recent implementation. Riders, using a phone app or by calling a designated phone number, request a ride in real-time or schedule in advance. The service uses software to automate and optimize trip requests based on trip request times, origin and destination locations, vehicle location, and vehicle capacity considerations. Vehicle operators receive and respond to trip assignments as they are requested in real time.

Additionally, the service is available and accessible to persons with disabilities in addition to the public. The concept promotes transit, provides efficient service in low-density areas, and enhances access to transit beyond current service areas. These services also serve as first/last-mile service for riders of regular fixed-route transit services.

The *Reimagine Transit* plan recommends significantly expanding on-demand transit over the next 10 years to meet localized mobility needs. The expanded and new microtransit service zones for the TDP are described below:

- **Expand ART On Demand North Port St. Lucie** – With the potential repurposing of Route 6, ART On Demand North service would be expanded to cover areas previously served by Route

6. The expanded zone would connect riders in the Port St. Lucie area to Route 1, the Port St. Lucie Intermodal Facility, IRSC - Pruitt campus, and other destinations along US 1. The expanded ART On Demand North would cover areas adjacent to Glades Cut Off Road to US 1 from Port St. Lucie Boulevard to areas south of Edwards Road.

- **New ART On Demand South Fort Pierce** – This zone enhances transit access and establishes on-demand service in south Fort Pierce and the Indian River Estates neighborhood. The zone covers areas south of Virginia Ave east of Selvitz Road, north of Easy Street, and bordering the expanded North Port St. Lucie zone. The traditional transit market segments and residents/workers in this zone would be connected to shopping centers within the zone, to neighboring on-demand zones, and to Routes 8 and to Route 1 that provide regional access. This zone would provide on-demand service Monday through Saturday.
- **New ART On Demand North Fort Pierce** – Microtransit in area south of Indian River County line and north of St Lucie Boulevard. This service would provide on-demand coverage to neighborhoods and businesses in the north Fort Pierce area. This zone expands coverage to a growing area while giving access to existing Routes 3 and 7, which provides access to Indian River County. Although data show potential demand, especially from traditional rider markets, currently there is no local neighborhood service other than the US 1 corridor. This zone would span from the Indian River County line to the expanded ART On Demand North Port St. Lucie zone bordering I-95 and operate Monday through Saturday.

Table 8-1 summarizes these improvements by route/service type at the end of the 10-Year TDP.

Table 8-1: ART 10-Year Needs Service Characteristics

Route	Headway	Weekday Service Span	Days of Service
<i>Fixed-Route</i>			
1	30	6:00 AM -10:00 PM	Monday - Sunday
2	60	6:00 AM -10:00 PM	Monday - Sunday
3	30	6:00 AM -10:00 PM	Monday - Sunday
4	60	6:00 AM -10:00 PM	Monday - Sunday
Streamlined 7	60	6:00 AM -10:00 PM	Monday - Friday
Extended 8	60	6:00 AM -10:00 PM	Monday - Saturday
Downtown/Passenger Rail/Beach Shuttle	15	6:00 AM -10:00 PM	Monday - Saturday
Port St. Lucie Express	Peak	5:00 AM - 8:00 AM; 5:30 PM - 8:30 PM	Monday - Friday
Airport/College Express	60	6:00 AM -6:00 PM	Monday - Friday
Dual Enrollment Shuttle	60	10:00 AM - 6:00 PM	Monday - Friday
Expanded TIM	Varies	10:00 AM – 2:00 PM; 5:00 PM - 9:00 PM	Monday - Sunday
<i>ART On Demand Microtransit</i>			
North Port St. Lucie	On-demand	6:00 AM -10:00 PM	Monday - Saturday
South Port St. Lucie	On-demand	6:00 AM -10:00 PM	Monday - Saturday
North Fort Pierce	On-demand	6:00 AM -10:00 PM	Monday - Saturday
South Fort Pierce	On-demand	6:00 AM -10:00 PM	Monday - Saturday

Capital/Infrastructure/Technology/Policy Needs

Implementation of these transit services should be supported by necessary capital infrastructure and technology improvements to ensure an enhanced experience for ART users. The following improvements have been identified to support the operational investments summarized previously.

New Port St. Lucie Intermodal Center

This new facility improvement in Port St. Lucie is already planned and, once completed, will replace the existing transfer center adjacent to the Port St. Lucie Community Center and Airosa Boulevard. Currently, it is estimated to cost \$3 million. ART has secured \$1.5 million from the FTA for construction and an additional \$1.5 million from FDOT. The project is currently in the design phase and will have restroom facilities and crime prevention through environmental design (CPTED) design features.

New ART Operations & Maintenance Facility

This new facility is already planned to centralize ART services (Figure 8-1). Located along Selvitz Road, it will consolidate transit operations, administration, maintenance, and vehicle storage.

Figure 8-1: ART Operations & Maintenance Facility Concept



Source: ART

Figure 8-2: High Ridership Bus Stop Concept



Source: FDOT

Invest in Bus Stop Infrastructure at High Ridership Stops

ART needs to continue investing in bus stop infrastructure such as shelters, benches, bike racks, and other amenities at its highest ridership stops to support the proposed new routes and enhancements to existing services (Figure 8-2). Furthermore, installing the appropriate level of amenities at bus stops may help attract more discretionary riders and provide current riders with a higher quality experience.

Vehicle Replacement/Alternative Fuel Vehicle Fleet Integration Program

ART should work with St. Lucie County, the St. Lucie TPO, and other partners to explore purchasing alternative fuel vehicles when implementing the previously identified service needs, especially with the new proposed services. ART should also consider acquiring alternative fuel buses as replacements to its current diesel fleet when possible, which may attract discretionary riders and also help ART’s overall marketing strategy to appeal to a wider population base.

Figure 8-3: TSP with Queue Jump Lane Concept

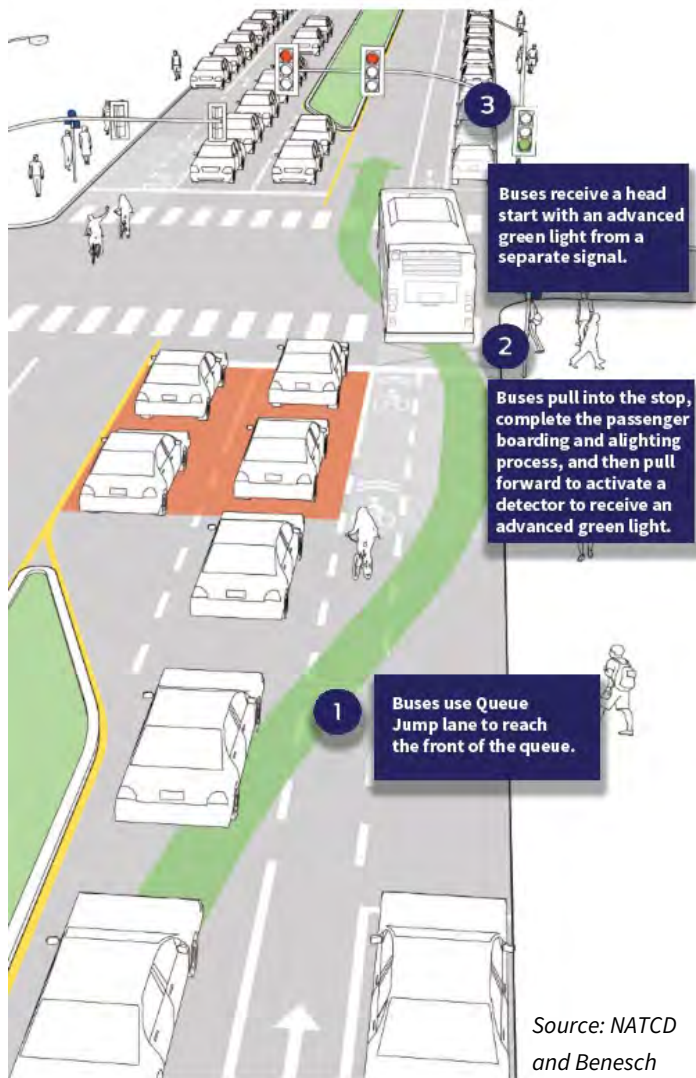

Bus Preferential Treatment

Traffic can impact the travel time of transit services operating in mixed traffic, possibly making transit unattractive to potential riders and unreliable for current riders. Bus preferential treatments such as Transit Signal Priority (TSP) and/or queue jumps may help buses to adhere to schedules during congested periods on key corridors such as US 1. Figure 8-3 shows a TSP and queue jump configuration example to help prioritize transit movement at an intersection.

TSP and/or queue jumps are recommended for selected intersections with high traffic volumes to improve transit’s appeal over driving on the same corridor. ART should coordinate with FDOT to plan and implement TSP and queue jumps along major transit corridors such as on US 1. Identifying intersections and specific technologies to deploy these measures will require a separate study.

Wi-Fi on Buses and Selected Bus Stops

Adding Wi-Fi on buses and at select high-ridership bus stops will add convenience while offering other practical benefits. Adding Wi-Fi at high-ridership bus stops will assist riders transferring from a fixed route to ART On Demand or access ART’s real-time bus information. Additionally, this feature can allow riders to work or complete schoolwork online while riding. Overall, this new feature will improve the overall rider experience while assisting ART with communication.

Enhanced Paratransit Service Eligibility Process

To make the program more efficient and cost feasible, St. Lucie County should improve the current ADA paratransit eligibility process by allowing doctors to certify riders to ensure fair and effective access to transportation.

Fare Policy/Structure Evaluation Study

ART should conduct a review and evaluation of its current fare-free structure within the next three years. With the popularity and potential expansion of ART On Demand services, this is an essential post-TDP need. ART should review the impacts of staying fare-free and the potential for implementing a fare structure and revised policies. This could include an analysis of new fare collection technology, peer system fare structures, and the estimated impact on ridership. It is also an optime time to conduct a fare policy/structure evaluation study in the “new normal” after the pandemic and at a time ART is reimagining its services.

It is recommended that St. Lucie County implements a fare structure, at a minimum, for the expanded ART On Demand service. The expanded service will connect to additional destinations quickly, making ART On Demand a premium service.

Expand Transit Marketing/Education Program

Although it is important to make transit more convenient to use and attractive to appeal to new ridership, it is equally important to ensure that the community is aware of where/when these services are available and how they work. Based on



input from the public and stakeholders, lack of awareness and education about ART’s services and facilities is a major hurdle to making transit a more viable option in St. Lucie County.

A carefully coordinated and multi-year marketing campaign and awareness strategy involving local stakeholders and businesses is recommended. While this TDP keeps the details and scale of this effort open, it strongly emphasizes the need for such a program prior to implementing the proposed *Reimagine Transit* improvements.

Establish Route-Level Performance Monitoring Program

A performance monitoring program tracks and measures the performance and efficiency of routes and the system. ART should continue its monitoring efforts and establish a performance monitoring program, similar to the sample process in Appendix E, for new transit services implemented in the next 10 years.



Evaluation of Transit Needs

This section presents the evaluation methodology for the 10-year transit needs to assess the strategies and help ART set meaningful priorities for funding over the next 10 years. The evaluation process is structured to cover a wide spectrum of factors that are qualitative and quantitative to ensure it is comprehensive.

A quantitative-qualitative hybrid methodology was used to evaluate and prioritize the transit needs. By conducting this evaluation, ART can meaningfully prioritize projects and allocate funding using an objective process. The four evaluation categories identified below and the category weights discussed were used to rank the TDP service needs.

- **Public Support** – A key reason for the success of any improvement is its acceptance and support by the community it serves and impacts. The conclusions from public outreach efforts and input from stakeholders are reviewed to gauge public support.
- **Potential Demand** – The findings from GIS-based technical analyses conducted as part of the demand/gap assessment and ridership projections are reviewed to assess the potential demand.
- **Activity Center Connectivity** – Connectivity to key activity centers and hubs play a critical role as ART focuses on enhancing services for residents and meeting the demands of creating a truly multimodal transportation system for their use.
- **Financial Feasibility** – Financial feasibility with funding often is one of the most restrictive factors and, therefore, is sometimes a heavily-weighted criterion. The costs of implementation were considered together with the associated funding and policy support.

Table 8-2 lists the evaluation criteria and their associated measures of effectiveness. Each measure and criterion are assigned a weight to relay the relative importance of each among the group of criteria.

Table 8-2: 10-Year TDP Service Needs Evaluation Factors and Weights

Criteria	Measure	Measure Description	Measure Weight	Criteria Weight
Public Support	General Public Input	Level of interest in specific alternatives (Very High, High, Moderate, None), gathered via TDP public input surveys	15%	35%
	Stakeholder Input	Level of interest in specific improvements (None, Moderate, High, Very High), gathered via the TDP outreach process	20%	
Ridership Potential	Traditional Market Coverage	Coverage of traditional markets (areas with a Transit Orientation Index rating of “High” or “Very High” from the TOI)	10%	25%
	Discretionary Market Coverage	Coverage of discretionary markets (areas with 4 or more jobs or dwelling units per acre from the DTA)	10%	
	Ridership Productivity	TBEST demand model trips per hour simulated 2034 ridership	5%	
Activity Center Connectivity	Connections to Key Destinations	Connections to key population and employment hubs within St. Lucie County and in the immediate region	10%	10%
Financial Feasibility	Cost Efficiency	Operating cost per trip	30%	30%
Total			100%	100%

Improvement Scoring Thresholds

A mix of qualitative and quantitative analyses is used to gain a more comprehensive understanding of priorities for ART. A score is assigned to each proposed improvement. For the quantitative criteria (e.g., traditional market, choice market, trips per hour, and operating cost per trip) the scoring is determined using the average of the entire data set and one standard deviation above or below the average. For the remaining qualitative criteria, the score is based on professional judgment of the information (i.e., collective stakeholder input) compared across the transit alternatives. A higher score is consistent with a higher ranking for a given alternative.

Table 8-3 shows the thresholds and scoring for each criterion used in the alternatives evaluation.

Table 8-3: 10- Year Needs Evaluation – Scoring Thresholds

Measure	Range	Score
General Public Input	Less than (Average – 1 SD)	1
	Between (Average – 1 SD) to Average	3
	More than Average to (Average + 1 SD)	5
	More than (Average + 1 SD)	7
Stakeholder Input	None	1
	Moderate	3
	High	5
	Very High	7
Traditional Market Potential	Low (Average – 1 SD)	1
	Average (Average – 1 SD to Average)	3
	High (Average to Average + 1 SD)	5
	Very High (Average to Average + 2 SD)	7
Discretionary Market Potential	Low (Average – 1 SD)	1
	Average (Average – 1 SD to Average)	3
	High (Average to Average + 1 SD)	5
	Very High (Average to Average + 2 SD)	7
Ridership Productivity (Trips per Hour)	Low (Average – 1 SD)	1
	Average (Average – 1 SD to Average)	3
	High (Average to Average + 1 SD)	5
	Very High (Average to Average + 2 SD)	7
Connections to Key Destinations	None	1
	Moderate	3
	High	5
	Very High	7
Cost Efficiency (Operating Cost per Trip)	Low (Average – 1 SD)	1
	Average (Average – 1 SD to Average)	3
	High (Average to Average + 1 SD)	5
	Very High (Average to Average + 2 SD)	7

Note: SD = statistical Standard Deviation

As noted, each criterion is assigned a weight, which allows measurement of the relative importance of each criterion among the group of criteria to be applied. For each transit improvement, a score was determined either through the computation of the selected measure of effectiveness or the educated judgment of the analyst. Potential scores were assigned depending on the relative comparison of a given transit improvement with other transit improvements as it relates to a given criterion. A higher score is consistent with a higher ranking for a given improvement for the criterion being evaluated. The thresholds for computation-based criteria were determined using the average of the entire data set and one standard deviation above or below the average.

Alternatives Evaluation Results Summary

Each improvement was evaluated using the process summarized previously, and the results are presented in Table 8-4, showing the service improvements scored based on the criteria and thresholds identified previously. Each improvement was scored and then ranked based on the score. Table 8-2 shows the rankings of each TDP service improvement, which identifies the priorities based on the evaluation methodology used. The rankings were used to assist in development of the implementation plan for the TDP improvements.

Table 8-4: 10- Year Service Improvements Evaluation Results

Ranking	Improvements	General Public Input	Stakeholder Input	Traditional Market Coverage	Discretionary Market Coverage	Ridership Productivity	Connections to Key Destinations	Cost Efficiency	Score
1	Expanded North Port St. Lucie Microtransit	7	7	5	7	7	7	7	6.8
2	30-minute Frequency on Routes 1 and 3	7	7	5	7	7	7	7	6.8
3	New North Fort Pierce Microtransit	7	7	7	5	7	5	7	6.6
4	Extend Weekday Service Span to 10PM	7	7	7	7	7	7	5	6.4
5	New South Fort Pierce Microtransit	7	7	3	5	5	7	7	6.3
6	Downtown/Rail Station/Beach Shuttle	7	5	5	5	5	7	7	6.1
7	Add Sun. Service on Routes 1, 2, 3, and 4	5	3	7	7	7	5	7	5.7
8	Extended Route 8	5	7	3	7	5	7	3	5
9	Dual Enrollment Shuttle	5	5	3	3	1	5	7	5
10	Add Saturday Service on Route 8	3	5	3	5	3	5	5	4.4
11	Streamline Route 7	1	1	5	3	7	3	7	3.9
12	Port St. Lucie Express	3	3	1	3	3	5	5	3.6
13	Airport/College Express	3	3	1	1	3	3	1	2



Section 9. Reimagine Transit: 10-Year Plan

This section summarizes the recommended 10-year transit plan for the *Reimagine Transit* TDP. This plan is crafted and derived from extensive data analysis along with input and support from the local community and its key stakeholders to reimagine transit services in St. Lucie County. The plan seeks to increase access and availability of alternative transportation modes within and adjacent to the county.

The recommended transit service, capital, technology, and policy improvements presented in this section are a culmination of the efforts conducted for this TDP, as summarized previously, to provide a road map to reimagine transit in St. Lucie County. This includes improvement projects that can be funded or are unfunded. The capital/operating cost and revenue assumptions used to develop these funded and unfunded priorities are summarized before presenting a financial plan for the 10-year TDP. Subsequently, the 10-year implementation plan to reimagine St. Lucie's transit also is detailed.

Reimagine Transit

With guidance and direction from St. Lucie TPO and St. Lucie County, the *Reimagine Transit* TDP was developed to rethink transit options throughout St. Lucie County. By reconfiguring and repurposing the traditional fixed-route bus network and expanding technology-based on-demand microtransit services significantly, transit in St. Lucie will serve more areas and a greater number of people and trip purposes.

Immediate and sweeping changes to the services currently provided are not intended nor included in the 10-year plan to not disproportionately impact any service area or communities currently served. However, the recommended plan does include a clear shift from providing traditional large-vehicle bus services to more technology-based microtransit services using smaller vehicles.

As shown in Figure 9-1, the geographic coverage area of traditional bus service would see a reduction from 39% to 16%, while on-demand microtransit service would increase from 39% to 84% over the next 10 years. However, the reimaged plan still includes the large-vehicle fixed-route bus service options, especially on major corridors, as they are more efficient in capacity and cost.

With the implementation of this TDP, the transit service coverage in St. Lucie County would increase by 96% by 2034, providing the residents and visitors of St. Lucie County a mix of transit services to connect locally and regionally, including an app- and phone-based microtransit system, fixed-route bus service on major roadway and in high demand areas, express buses to connect regionally, and a vanpool program.

Figure 9-1: Mode Share / Existing and Reimagine Transit

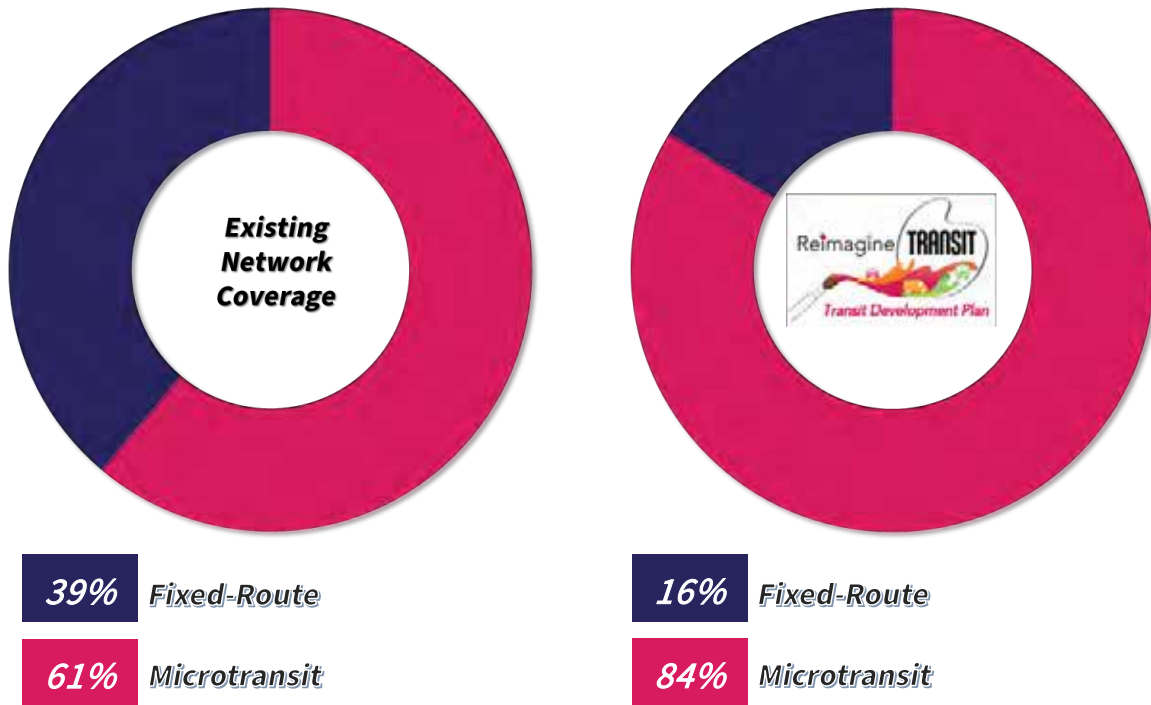

96% increase in service coverage

The recommended 10-year service, capital, and technology improvements for the *Reimagine Transit* plan, presented in the remainder of this section, were derived after examining the previously presented needs with consideration to community direction, an understanding of the unique environment, review of goals and objectives, and demand assessments in conjunction with the projected funding sources. The recommended services are identified under each of the major improvement categories, including service, capital/infrastructure, and policy.

Service Improvements

The *Reimagine Transit* TDP service improvements that support the reconfiguration of service in St. Lucie County include the following.

Enhance Existing Fixed-Route Bus Route Network

- **30-minute Frequency on Routes 1 and 3** – Increase headways on Routes 1 and 3, which are the most productive ART routes today, to 30 minutes to create a high-frequency network. Routes 1 and 3 will also connect with other ART routes at the Fort Pierce Intermodal Center, extending its reach.

- **Add Sunday Service on Routes 1, 2, 3, 4** – Add limited Sunday service on Routes 1, 2, 3, and 4 to provide riders who utilize these highly productive routes with daily service to key locations and corridors.
- **Repurpose Route 5** – Discontinue Route 5 and repurpose resources to extend Route 8.
- **Repurpose Route 6** – Discontinue Route 6 and repurpose resources into expanding ART On Demand microtransit within the Route 6 service area.
- **Streamline Route 7** – Realign segments of Route 7 to better serve residents in north St. Lucie County by creating north and south connectivity on Turnpike Feeder Road and US 1.
- **Extend Route 8** – Use repurposed resources from Route 5 to extend Route 8 from its current terminus at the Port St. Lucie Intermodal Center to the Tradition area. This route will then provide a one-seat ride between Fort Pierce and Tradition as well as to the Jobs Express Park-and-Ride, which is served by the new regional bus service from Palm Beach County.
- **Add Saturday Service on Route 8** – Add Saturday service on extended Route 8 will provide a direct weekend connection from Fort Pierce to the Tradition area.
- **Extend Service Span to 10 PM** – The ART fixed-route network will provide service until 10 PM to extend transit service/access to later hours on weekdays.

Add New Services

- **Port St. Lucie Express** – A regional connection from Jobs Express Park-and-Ride in Port St. Lucie to Palm Beach County, linking ART to the Palm Tran bus network.
- **Downtown/Rail Station/Beach Shuttle** – Quick and high-frequency downtown-based service that will connect Downtown Fort Pierce to ART Intermodal Center, beaches on Hutchinson Island, and any future passenger rail station in Fort Pierce (location to be determined).
- **Dual Enrollment Shuttle** – Shuttle service that will connect selected high schools in St. Lucie County to IRSC campuses.
- **Establish Vanpool Program** – A collaborative effort led by ART with South Florida Commuter Services to establish a well-coordinated vanpool program, adding another layer of travel alternatives in St. Lucie County.

Expand On-Demand Microtransit Services

The most significant improvement in the *Reimagine Transit* plan is the expansion of technology-based on-demand microtransit for St. Lucie County in the next 10 years. In addition to continuing the two existing and popular ART On Demand zones in the north and south Port St. Lucie areas, the plan recommends expanding ART On Demand microtransit services to substantially widen transit access in most of the populated areas in St. Lucie County over the next 10 years. The recommended plan expands the microtransit coverage, identified previously in the 10-year needs plan, to even more areas, based on input from the recent TDP Phase II public outreach efforts, County staff direction, and a review of available and projected revenues. The recommended new microtransit service zones for the *Reimagine Transit* TDP, as summarized below, will offer an additional 121 square miles of transit access in St. Lucie County, compared to 71 square miles today.

- **New ART On Demand Central Fort Pierce** – This zone would add on-demand transit in the area adjacent to the Treasure Coast International Airport/south of Indrio Road and north of St Lucie Boulevard. This service would provide on-demand coverage to neighborhoods and businesses in the Fort Pierce area in addition to the IRSC-Massey campus. This zone expands coverage to a growing area while giving access to existing local Routes 2 and 3 and a regional connection to Indian River County, Route 7.
- **New ART On Demand North St. Lucie** – This on-demand transit zone enhances transit access and establishes on-demand service in north St. Lucie County, an area that only has transit access to regional Route 7 at this time. The zone covers areas south of Indian River County and borders the Central Fort Pierce zone while connecting to the Fort Pierce Intermodal Center.
- **New ART On Demand Indian River Estates** – This new on-demand transit zone would connect riders in the Indian River Estates/Port St. Lucie area to Route 1 (which is proposed to operate every 30 minutes) and the extended Route 8, the Fort Pierce Intermodal Facility, and other destinations along US 1 north of Prima Vista Boulevard.
- **New ART On Demand South St. Lucie** – This new on-demand transit zone aims to connect riders in the southeastern part of St. Lucie within the area and to Routes 1 and 4, the Port St. Lucie Intermodal Facility, and various destinations along US 1 and Port St. Lucie Boulevard.
- **Maintain ART On Demand North Port St. Lucie** – The existing ART On Demand North service will be maintained, serving south of the Crosstown Parkway to the Midway Road area and west of 25th Street to areas near Glades Cutoff Road. This zone will also cover areas previously served by Route 6 while connecting riders in the Port St. Lucie area to extended Route 8, the Port St. Lucie Intermodal Facility and IRSC’s Pruitt campus.
- **Maintain ART On Demand South Port St. Lucie** – The existing ART On Demand South Port St. Lucie would continue to serve areas south of the Crosstown Parkway to the St. Lucie County line from the Tradition area to the St. Lucie River. Like ART On Demand North Port St. Lucie, this zone will also connect to the Port St. Lucie Intermodal Facility in addition to the Jobs Express and Bayshore Park and Ride facilities.

Map 9-1 shows the recommended 10-Year plan.

Map 9-1: 2034 Reimagine Transit Network

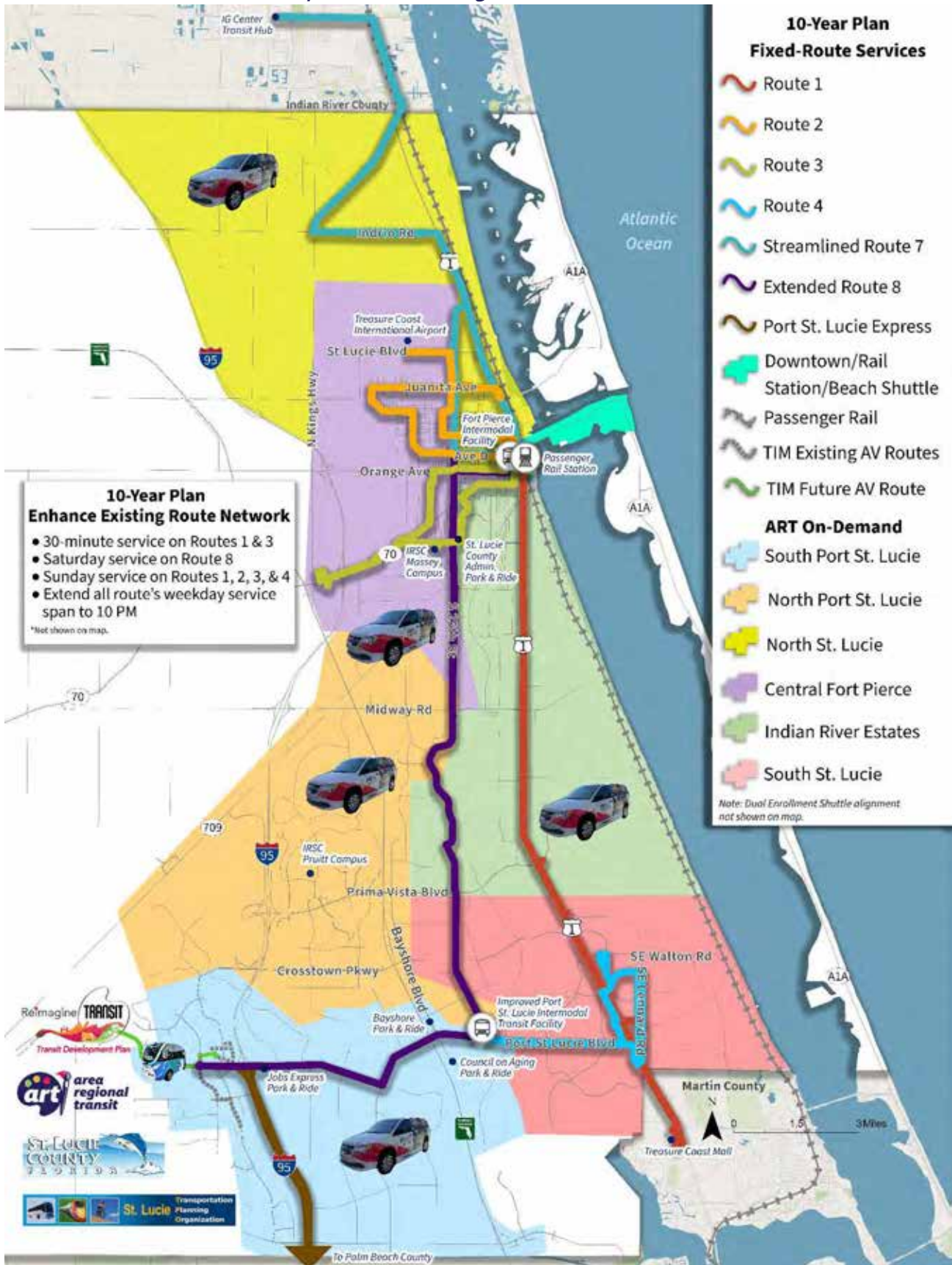

Table 9-1: Recommended ART 10-Year Network Characteristics

Route	Headway	Weekday Service Span	Days of Service
<i>Fixed-Route</i>			
1	30	6:00 AM–10:00 PM	Monday –Sunday
2	60	6:00 AM–10:00 PM	Monday–Sunday
3	30	6:00 AM–10:00 PM	Monday–Sunday
4	60	6:00 AM–10:00 PM	Monday–Sunday
Streamlined 7	60	6:00 AM–10:00 PM	Monday–Friday
Extended 8	60	6:00 AM–10:00 PM	Monday–Saturday
Downtown/Passenger Rail Station/Beach Shuttle			
	15	6:00 AM–10:00 PM	Monday–Saturday
Port St. Lucie Express	Peak Only	2 trips AM & PM Peak	Monday–Friday
Dual Enrollment Shuttle	60	10:00 AM–6:00 PM	Monday–Friday
Expanded TIM	Varies	10:00 AM–2:00 PM; 5:00 PM–9:00 PM	Monday–Sunday
<i>ART On Demand Microtransit</i>			
North Port St. Lucie	On-demand	6:00 AM–10:00 PM	Monday –Saturday
South Port St. Lucie	On-demand	6:00 AM–10:00 PM	Monday–Saturday
Central Fort Pierce	On-demand	6:00 AM -10:00 PM	Monday–Saturday
North St. Lucie	On-demand	6:00 AM -10:00 PM	Monday–Saturday
Indian River Estates	On-demand	6:00 AM -10:00 PM	Monday–Saturday
South St. Lucie	On-demand	6:00 AM -10:00 PM	Monday–Saturday

Capital/Policy/Technology Improvements

- New ART Operations & Maintenance Facility**– The proposed operations and maintenance facility in St. Lucie County, now in the concept phase and expected to be located along Selvitz Road, will assist in supporting operations and increasing demand for services with the projected growth in the County. The facility will consolidate maintenance, administration, operations, vehicle parking, and vehicle maintenance to one single site for better coordination and efficiency. Partial funding for this facility has already been identified and future competitive grant funding will be pursued for the remaining amount needed.
- New Port St. Lucie Intermodal Center** – The new Port St. Lucie Intermodal Center, which will be built at the same location ART currently uses as a key transfer point, is currently in the design phase and is soon expected to be advertised for a construction bid. The new and enhanced facility will feature six bus bays and incorporate CPTED design features along with restrooms.

performance and efficiency of routes and the system as a whole and provides a convenient tool for ensuring the provision of efficient and effective transit service.

- **Deploy TSP/queue jumps at selected intersections** – TSP technologies and queue jumps will be deployed at applicable intersections on US-1 as part of implementing the enhancement of Route 1 service. Currently, there are 12 signalized intersections along US-1 selected for TSP and 12 selected for queue jumps. However, further evaluations/studies are necessary to determine the actual scale of deployment prior to implementing the technology.
- **Fare Policy/Structure Evaluation Study** – ART has been fare-free since 2017. ART should conduct a study to evaluate potential systemwide changes to fare amount and policy along with the resulting implications.
- **Continue fleet replacement and acquisition program** – As previously noted, ART should continue vehicle replacements and acquisitions to operate the proposed 10-year network.

10-Year TDP Financial Plan

A financial plan was developed and is summarized in this section to help program and facilitate the implementation of TDP improvements in the next 10 years. The cost and revenue assumptions used to develop the financial plan and a summary of cost and revenue projections are presented. The summary includes annual costs for service and capital projects including infrastructure, technology, or policy improvements programmed for implementation within the next 10 years and supporting revenues that are reasonably expected to be available to fund the implementation.

Operating Cost Assumptions

Numerous assumptions were made to forecast transit operating costs from 2025 through 2034. These assumptions are based on data from ART and other transit industry data. Key operating cost assumptions include the following:

- Operating costs for fixed-route services were estimated using an operating cost per revenue hour of \$84.96 (2024\$), based on an analysis of current and historical performance data provided by ART.
- Operating costs for current and new ART On Demand services were estimated using a per revenue hour cost of \$26.23 (2024\$) for FY2025, based information provided by ART. Due to an anticipated new contract, an increase in cost is expected and an estimated revenue hour cost of \$50.00 was used subsequently.
- Operating costs for paratransit, Advantage Ride, Direct Connect, and other purchased transportation services and associated software and other expenses are based on information provided by ART.
- Establishing and maintaining a vanpool program is estimated at \$100,000 (2025\$) annually. The cost was estimated based on the peer review in the St. Lucie Vanpool Assessment.
- As TIM services are privately funded, the operating costs for current or future TIM services are not included in this plan.

- As previously noted, the Dual Enrollment and Downtown/Passenger Rail Station/Beach Shuttles’ routing are not yet determined. For cost calculation purposes, the following was assumed:
 - The Dual Enrollment Shuttle is to operate 8 hours a day during weekdays only using 2 vehicles.
 - The Downtown/Passenger Rail Station/Beach Shuttle is to operate 16 hours a day on weekdays and Saturdays using 1 vehicle.
- Based on data from ART, an inflation rate of approximately 2% was assumed. Salaries, which are categorized under “Other Expenses,” are inflated at a rate of 3%.

Capital/Infrastructure Cost Assumptions

Several assumptions were made to project costs for infrastructure/technology needs to support implementation of the service alternatives described previously. These capital cost assumptions include the following:

- Based on data from ART an inflation rate of 2% was assumed.
- The cost of the Port St. Lucie Intermodal and Operations and Maintenance Facility architectural and engineering design and construction permitting, provided by ART, is assumed at \$1.45 million (2025\$) annually for FY2025 and FY2026. The construction of the Operations and Maintenance Facility is pending grant funding but is expected to cost \$30 million.
- The costs of technology upgrades, bus stop/shelter improvements, and planning studies were based on information provided by ART.
- The cost of deploying TSP at an intersection is assumed to be \$25,000 (2024\$) and converting existing right-turn lanes to queue jump lanes at an intersection is assumed at \$150,000 (2024\$) per intersection. These assumptions are based on recent data from studies in the southeast region of the U.S. This plan assumes there will be 12 intersections in which TSP and queue jumps will be deployed.
- The cost of Wi-Fi on buses is assumed to be \$25,000 (2024\$) annually with an initial set-up cost of \$100,000 (2024\$). This assumption is based on recent data from studies in the southeast region of the U.S.

Vehicle Replacement/Acquisition

The vehicle replacement plan is a critical component of the financial plan. Figure 9-3 shows the cost for replacement and new vehicles by year for the TDP. The FTA-standard rate of 20 percent spare vehicle ratio is assumed for any new vehicle purchases.

The following assumptions were made:

- Vehicle life cycle (in years) assumptions are based on guidance from ART and include 12 years for fixed-route buses and 7 years for paratransit buses.

- Replacement vehicles planned to be purchased include those necessary to replace vehicles within the existing fleet that will reach the end of their useful life within the TDP planning period.
- The cost of a diesel bus is assumed at \$600,000 (2024\$) and the cost of a microtransit van is assumed at \$74,897 (2024\$), derived from data provided by ART staff.
- Due to the implementation of the ART On Demand Central Fort Pierce in FY2025, it was assumed that these vehicles have already been acquired.
- As previously noted, an annual growth rate of 2% is used for capital cost projections, including vehicles.

Figure 9-3: 10-Year Vehicle Replacement and Acquisition Cost Plan

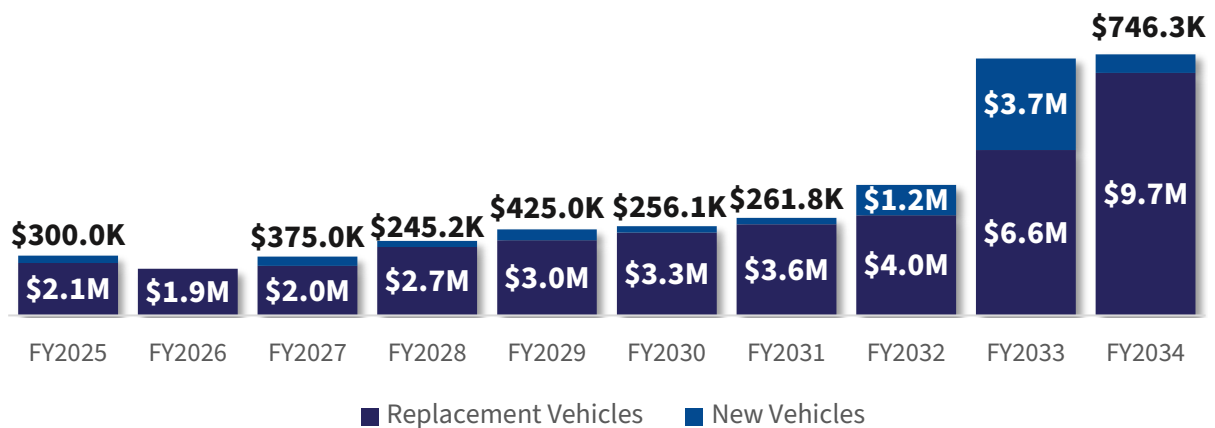

Other Cost Assumptions

When developing capital or operational improvements, it is important to anticipate supporting services such as additional planning resources and education/ marketing campaign costs. The following assumptions were made:

- The cost of expanding the transit marketing/education program is assumed at \$100,000 (2024\$) annually, beginning in FY2026.
- The Transit Fare and Financial Study is assumed to be \$300,000 (2026\$).

Revenue Assumptions

Several revenue-related assumptions were used to project streams of revenue to support the 10-year TDP implementation. Revenue assumptions and projections for ART are based on data from ART staff, and information on transit industry/FDOT funding programs. The basic structure/composition of ART’s mix of funding sources today, including federal, state, local, and agency-generated revenues, is expected to continue for the next 10 years.

The following additional key assumptions were used to project *Reimagine Transit* TDP revenues:

- Revenue projections from federal sources, including annual FTA formula grant funds and short-term grants, are based on information from ART.

- Contributions from the FTA 5307 Coronavirus Aid, Relief, and Economic Security (CARES) Act are assumed at \$2.7 million (2025\$) in FY2025.
- Projections for existing funds from FDOT, such as Block Grant funding, are assumed to continue, per ART.
- Projections for existing FDOT grants, such as Corridor Development and Service Development funding, are assumed to continue until FY2026, per ART.
- The Florida Commission for Transportation Disadvantaged trip and equipment funding is expected to continue at \$692,800 (2025\$) annually.
- Local sources, including Municipal Service Taxing Unit (MSTU) funds, are assumed at \$8.4 million annually (2025\$). Reserves from MSTU are expected to contribute \$4.3 million (2025\$) for FY2025. Contributions from the MSTU for buildings are expected to contribute \$53,250 (2025\$) in FY2025.
- Contributions from the General Fund are expected to be \$5.5 million (2025\$) in FY2025.
- Other revenues include Clear Channel advertising, \$66,105 (2025\$) annually, and interest on investments, \$20,240 (2025\$) annually.
- Capital funds that are expected to roll over from the previous fiscal year are \$867,715 (2025\$) in FY2025.
- This plan assumes additional new funding to assist with the implementation of key projects to improve the attractiveness of transit for discretionary riders and increase the quality of service for existing riders locally and regionally.
 - A new Federal Section 5310 Operating grant is expected to contribute \$100,000 (FY2026\$) annually from FY2026 to FY2034.
 - A new Federal Section 5310 Travel Training grant is assumed to cover \$803,179 from FY2025 to FY2034.
 - A new Federal Section 5311 grant is assumed to cover \$642,978 from FY2025 to FY2034.
 - A new FDOT Service Development grant would cover partial operating expenses for new microtransit zones.
 - A new FDOT Intermodal Grant, assumed at \$1.5 million (2025\$), would help cover a portion of the Port St. Lucie Intermodal Center.
 - A new FDOT grant would help cover replacement and new vehicles.
 - Additionally, FDOT Corridor Development funding in partnership with PalmTran will cover operating and capital expenses for the Port St. Lucie Express.
 - The South Florida Commuter Services would provide funding for the vanpool services, assumed at \$100,000 (2025\$) annually.
 - New local or grant funding, totaling \$28 million, is needed to fund the Operations and Maintenance facility and the Port St. Lucie Intermodal Facility.
- As ART is currently fare-free, the plan assumes no change to the current fare policy and no fare revenues.

10-Year Cost/Revenue Summary

Annual operating and capital costs and supporting revenues for ART are summarized in Table 9-2. As shown, it would cost \$188.9 million to operate ART services in the next 10 years, with another \$46.4 million in capital costs to support the necessary fleet and capital infrastructure. Operating costs would continue to be funded mainly with a mix of local, state, and federal sources.

Figure 9-4 shows the annual operating and capital costs for the *Reimagine Transit* TDP implementation plan, and Figure 9-5 shows the total costs and revenues by year to support it. Figure 9-6 shows the expected revenues by source.

Figure 9-4: Total Costs – Operating and Capital

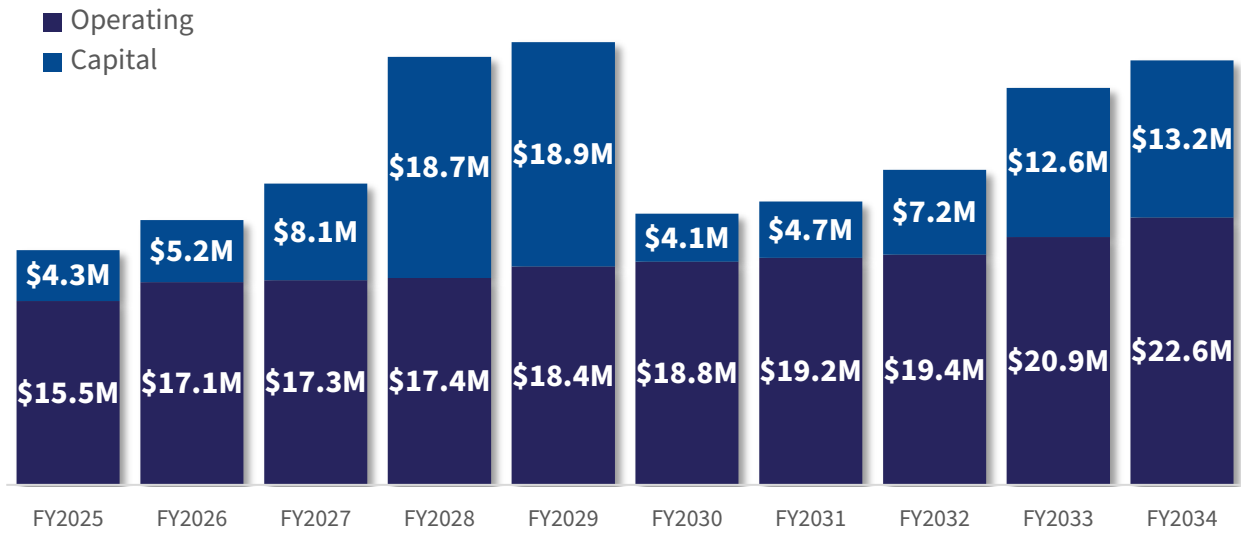

Figure 9-5: Total Costs and Revenues

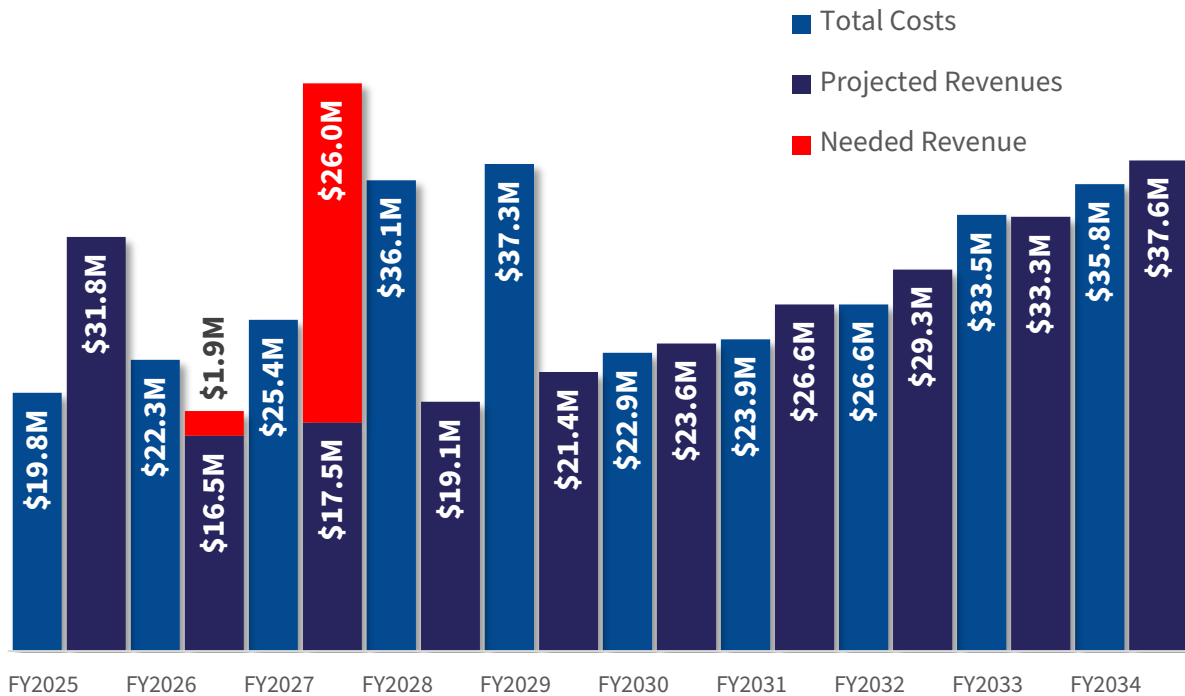
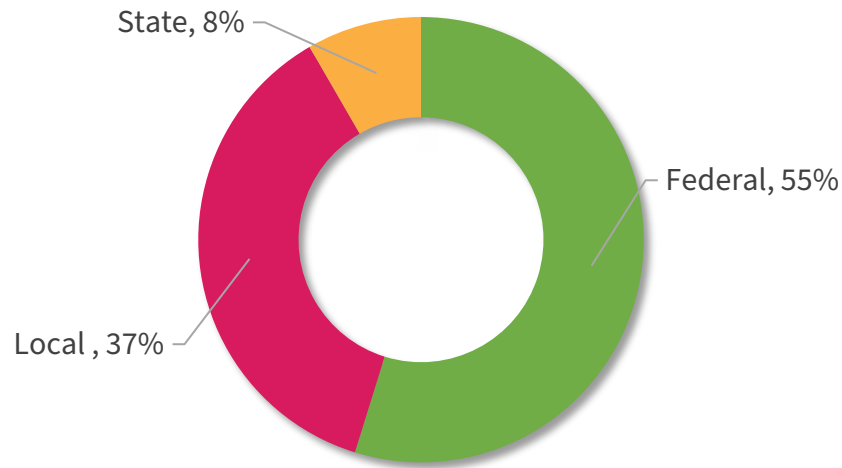

Table 9-2: 10-Year Financial Plan

Cost/Revenue	FY2025	FY2026	FY2027	FY2028	FY2029	FY2030	FY2031	FY2032	FY2033	FY2034	Total
Operating Costs											
Existing ART Fixed-Route	\$3,420,105	\$3,488,508	\$3,558,278	\$3,629,443	\$3,702,032	\$3,776,073	\$3,059,926	\$3,121,124	\$3,183,547	\$3,247,218	\$34,186,253
Existing ART On-Demand (Zone 1 and 2)	\$1,350,320	\$3,042,000	\$3,102,840	\$3,163,680	\$3,224,520	\$3,285,360	\$3,346,200	\$3,407,040	\$3,467,880	\$3,528,720	\$30,918,560
Paratransit	\$4,520,304	\$4,429,898	\$4,341,300	\$4,254,474	\$4,211,929	\$4,169,810	\$4,128,112	\$4,086,831	\$4,045,962	\$4,005,503	\$42,194,123
Advantage Ride	\$152,550	\$155,143	\$157,781	\$160,463	\$163,191	\$165,965	\$168,787	\$171,656	\$175,089	\$178,591	\$1,649,216
Direct Connect	\$459,318	\$468,504	\$477,874	\$487,432	\$497,181	\$507,124	\$517,267	\$527,612	\$538,164	\$548,928	\$5,029,404
Purchased Transportation Staffing and Maintenance	\$2,409,637	\$2,323,507	\$2,369,977	\$2,417,377	\$2,465,724	\$2,515,039	\$2,565,339	\$2,616,646	\$2,668,979	\$2,722,359	\$25,074,584
Software	\$452,032	\$219,078	\$223,459	\$227,928	\$246,886	\$251,823	\$266,051	\$278,118	\$283,681	\$289,354	\$2,738,410
Other Operating Expenses	\$1,373,799	\$1,012,038	\$1,041,098	\$1,071,004	\$1,101,780	\$1,133,453	\$1,166,049	\$1,199,594	\$1,223,586	\$1,248,057	\$11,570,457
New Vanpool Program	\$100,000	\$102,000	\$104,040	\$106,121	\$108,243	\$110,408	\$112,616	\$114,869	\$117,166	\$119,509	\$1,094,972
New ART On-Demand Microtransit	\$368,269	\$936,000	\$954,720	\$973,440	\$1,736,280	\$1,769,040	\$2,574,000	\$2,620,800	\$3,467,880	\$3,528,720	\$18,929,149
30-minute Frequency on Route 1	\$702,979	\$717,039	\$731,380	\$746,007	\$760,928	\$776,146	\$791,669	\$807,502	\$823,652	\$840,125	\$7,697,429
Extended Route 8	\$182,351	\$186,373	\$190,483	\$194,684	\$198,978	\$203,366	\$207,851	\$212,435	\$217,120	\$221,909	\$2,015,549
Sunday Service on Routes 1, 2, 3, & 4	\$0	\$0	\$0	\$0	\$0	\$151,072	\$154,404	\$157,809	\$161,289	\$164,847	\$789,420
Add Saturday Service on Route 8	\$0	\$0	\$0	\$0	\$0	\$0	\$92,642	\$94,685	\$96,774	\$98,908	\$383,009
30-minute Frequency on Route 3	\$0	\$0	\$0	\$0	\$0	\$0	\$0	\$0	\$427,691	\$437,124	\$864,815
Extend Weekday Service to 10PM	\$0	\$0	\$0	\$0	\$0	\$0	\$0	\$0	\$0	\$427,756	\$427,756
Dual Enrollment Shuttle	\$0	\$0	\$0	\$0	\$0	\$0	\$0	\$0	\$0	\$427,756	\$427,756
Downtown/Rail Station/Beach Shuttle	\$0	\$0	\$0	\$0	\$0	\$0	\$0	\$0	\$0	\$515,674	\$515,674
Total Operating Costs	\$15,491,665	\$17,080,087	\$17,253,229	\$17,432,052	\$18,417,671	\$18,814,679	\$19,150,912	\$19,416,722	\$20,898,461	\$22,551,056	\$186,506,535
Capital Costs											
New Vehicles	\$300,000	\$0	\$375,000	\$245,178	\$425,000	\$256,112	\$261,761	\$1,214,404	\$3,650,799	\$746,263	\$7,474,517
Replacement Vehicles	\$2,086,458	\$1,865,393	\$1,974,829	\$2,730,000	\$3,003,000	\$3,303,300	\$3,633,630	\$3,996,993	\$6,595,038	\$9,672,723	\$38,861,365
Vehicles	\$2,386,458	\$1,865,393	\$2,349,829	\$2,975,178	\$3,428,000	\$3,559,412	\$3,895,391	\$5,211,397	\$10,245,837	\$10,418,986	\$46,335,882
Planning Studies	\$0	\$0	\$0	\$200,000	\$0	\$0	\$0	\$300,000	\$250,000	\$300,000	\$1,050,000
Transit Fare & Financial Study	\$0	\$300,000	\$0	\$0	\$0	\$0	\$0	\$0	\$0	\$0	\$300,000
Technology Upgrades	\$385,000	\$500,000	\$0	\$0	\$0	\$0	\$337,849	\$344,606	\$351,498	\$717,056	\$2,636,008
New and Existing Bus Stop/Shelter Improvements	\$108,704	\$221,756	\$226,191	\$230,715	\$235,329	\$240,036	\$244,837	\$374,600	\$764,184	\$779,468	\$3,425,821
O+M Facility	\$1,207,000	\$1,207,000	\$0	\$15,000,000	\$15,000,000	\$0	\$0	\$0	\$0	\$0	\$32,414,000
PSL Intermodal Facility	\$215,500	\$215,500	\$4,500,000	\$0	\$0	\$0	\$0	\$0	\$0	\$0	\$4,931,000
Expand Transit Marketing/Education Program	\$0	\$208,919	\$213,527	\$218,236	\$223,049	\$227,968	\$232,996	\$476,269	\$486,773	\$995,018	\$3,282,755
TSP	\$0	\$104,460	\$106,763	\$0	\$0	\$0	\$0	\$59,534	\$60,847	\$0	\$331,603
Queue Jumps	\$0	\$626,757	\$640,580	\$0	\$0	\$0	\$0	\$357,202	\$365,080	\$0	\$1,989,619
Wi-Fi on Buses	\$0	\$0	\$100,000	\$27,279	\$27,881	\$28,496	\$29,125	\$29,767	\$30,423	\$31,094	\$304,066
Other Capital and Policy	\$1,916,204	\$3,384,392	\$5,787,061	\$15,676,231	\$15,486,260	\$496,500	\$844,806	\$1,941,978	\$2,308,805	\$2,822,635	\$50,664,872
Total Capital Costs	\$4,302,662	\$5,249,785	\$8,136,890	\$18,651,409	\$18,914,260	\$4,055,912	\$4,740,197	\$7,153,375	\$12,554,643	\$13,241,622	\$97,000,754
Revenues											
Local Operating Funds											
MSTU	\$8,416,621	\$8,584,953	\$8,756,652	\$8,931,786	\$9,110,421	\$9,292,630	\$9,478,482	\$9,668,052	\$9,861,413	\$10,058,641	\$92,159,652
MSTU Reserves	\$4,336,883	\$0	\$0	\$0	\$0	\$0	\$0	\$0	\$0	\$0	\$4,336,883
South Florida Commuter Services	\$100,000	\$102,000	\$104,040	\$106,121	\$108,243	\$110,408	\$112,616	\$114,869	\$117,166	\$119,509	\$1,094,972
Federal Funds											
Supergrant- 5307	\$2,447,711	\$2,937,253	\$3,524,704	\$4,229,645	\$5,075,574	\$6,090,688	\$7,308,826	\$8,770,591	\$10,524,709	\$12,629,651	\$63,539,352
5310 Operating Grant	\$0	\$100,000	\$102,000	\$104,040	\$106,121	\$108,243	\$110,408	\$112,616	\$114,869	\$117,166	\$975,463
5310 Travel Training	\$159,456	\$0	\$75,000	\$76,500	\$78,030	\$79,591	\$81,182	\$82,806	\$84,462	\$86,151	\$803,179
5311	\$128,000	\$0	\$60,000	\$61,200	\$62,424	\$63,672	\$64,946	\$66,245	\$67,570	\$68,921	\$642,978
State Funds											
FDOT Corridor Development	\$300,000	\$300,000	\$0	\$0	\$0	\$0	\$0	\$0	\$0	\$0	\$600,000
FDOT Block Grant	\$766,399	\$781,727	\$797,362	\$813,309	\$829,575	\$846,166	\$863,090	\$880,352	\$897,959	\$915,918	\$8,391,855
FDOT Service Dev- Micro Zone 2	\$429,647	\$159,098	\$0	\$0	\$0	\$0	\$0	\$0	\$0	\$0	\$588,745
FCTD Trip & Equipment Grant	\$692,844	\$706,701	\$720,835	\$735,252	\$749,957	\$764,956	\$780,255	\$795,860	\$811,777	\$828,013	\$7,586,448
FDOT Service Development- New Micro Zones	\$0	\$0	\$0	\$0	\$432,515	\$440,744	\$839,693	\$465,336	\$873,940	\$889,453	\$3,941,681
Other Revenues											
Clear Channel Advertising	\$66,105	\$67,427	\$68,776	\$70,151	\$71,554	\$72,985	\$74,445	\$75,934	\$77,453	\$79,002	\$723,831
Interest on Investments	\$20,340	\$20,747	\$21,162	\$21,585	\$22,017	\$22,457	\$22,906	\$23,364	\$23,832	\$24,308	\$222,717
Total Operating Revenues	\$17,864,066	\$13,759,906	\$14,230,530	\$15,149,587	\$16,646,430	\$17,892,541	\$19,736,850	\$21,056,024	\$23,455,148	\$25,816,733	\$185,607,757
Capital Revenues											
Local Funds- taken from operations	\$390,000	\$0	\$0	\$0	\$0	\$0	\$0	\$0	\$0	\$0	\$390,000
General Fund 316	\$4,248,000	\$0	\$0	\$0	\$0	\$0	\$0	\$0	\$0	\$0	\$4,248,000
General Fund 316 Reserves	\$1,000,000	\$0	\$0	\$0	\$0	\$0	\$0	\$0	\$0	\$0	\$1,000,000
General Fund 001 (Building - 562000)	\$230,564	\$0	\$0	\$0	\$0	\$0	\$0	\$0	\$0	\$0	\$230,564
MSTU Buildings 130 (552200)	\$53,250	\$0	\$0	\$0	\$0	\$0	\$0	\$0	\$0	\$0	\$53,250
FTA Super Grant (5307 + 5339)	\$2,287,752	\$2,745,302	\$3,294,363	\$3,953,235	\$4,743,883	\$5,692,659	\$6,831,191	\$8,197,429	\$9,836,915	\$11,804,298	\$59,387,027
FTA/BDOT 5310 Vehicle grant	\$593,409	\$0	\$0	\$0	\$0	\$0	\$0	\$0	\$0	\$0	\$593,409
FDOT Intermodal Grant	\$1,500,000	\$0	\$0	\$0	\$0	\$0	\$0	\$0	\$0	\$0	\$1,500,000
FTA 5307 CARES Act Grant (130138)	\$2,724,971	\$0	\$0	\$0	\$0	\$0	\$0	\$0	\$0	\$0	\$2,724,971
Capital Funds Rolled Over	\$867,715	\$0	\$0	\$0	\$0	\$0	\$0	\$0	\$0	\$0	\$867,715
New Local or Grant Funds Needed	\$0	\$1,900,000	\$26,000,000	\$0	\$0	\$0	\$0	\$0	\$0	\$0	\$27,900,000
Total Capital Revenues	\$13,895,661	\$4,645,302	\$29,294,363	\$3,953,235	\$4,743,883	\$5,692,659	\$6,831,191	\$8,197,429	\$9,836,915	\$11,804,298	\$98,894,936
All Revenues	\$31,759,667	\$18,405,209	\$43,524,893	\$19,102,823	\$21,390,313	\$23,585,200	\$26,568,040	\$29,253,453	\$33,292,063	\$37,621,031	\$284,502,692
10-Year Cost & Revenue Summary											
Total Revenues	\$31,759,667	\$18,405,209	\$43,524,893	\$19,102,823	\$21,390,313	\$23,585,200	\$26,568,040	\$29,253,453	\$33,292,063	\$37,621,031	\$284,502,692
Total Costs	\$19,794,327	\$22,329,872	\$25,390,120	\$36,083,463	\$37,331,931	\$22,870,592	\$23,891,109	\$26,570,096	\$33,453,104	\$35,792,677	\$283,507,289
Revenues Minus Costs	\$11,965,340	-\$3,924,663	\$18,134,773	-\$16,980,638	-\$15,941,618	\$714,608	\$2,676,932	\$2,683,357	-\$161,040	\$1,828,354	
Rollover from Prev. Year	\$0	\$11,965,340	\$8,040,676	\$26,175,450	\$9,194,811	-\$6,746,807	-\$6,032,199	-\$3,355,267	-\$671,910	-\$832,950	
Surplus/Shortfall	\$11,965,340	\$8,040,676	\$26,175,450	\$9,194,811	(\$6,746,807)	(\$6,032,199)	(\$3,355,267)	(\$671,910)	(\$832,950)	\$995,404	\$995,404

Figure 9-6: 10-Year Revenue Distribution



10-Year TDP Implementation Plan

The implementation plans presented in Tables 9-3 and 9-4, respectively, outline operating and capital improvements that are funded in the 10-Year TDP, as well as unfunded needs. The tables also show the implementation years, operating and capital costs associated with the improvements, and the type of anticipated funding sources for the plan.

It should be noted that the schedule shown in the table does not preclude the opportunity to delay or advance any projects. As priorities change, funding assumptions do not materialize, and/or more funding becomes available, this project implementation schedule can and should be adjusted.

Table 9-3: Reimagine Transit TDP Implementation Plan and Unfunded Needs / Service

Improvements	Funding Status	Implementation Year (FY)	Annual Operating Cost (2025\$)	Total Capital Cost (2025\$)	Potential Revenue Source	TDP Goal/Objective
Central Fort Pierce ART On Demand	Funded	2025	\$368,269	\$224,691	Local/FDOT Serv. Dev.	① ② ⑤
Port St. Lucie Express	Funded	2025	\$1,100,000	N/A	FDOT Corridor Dev./PalmTran	① ② ③ ⑤
30-minute Frequency on Route 1	Funded	2025	\$702,979	N/A	Local	① ② ⑤
Streamline Route 7	Funded	2025	\$0	N/A	Local	① ② ⑤
Extended Route 8	Funded	2025	\$182,351	N/A	Local	① ② ⑤
Establish Vanpool	Funded	2025	\$100,000	N/A	Local	① ② ⑤
South St. Lucie ART On Demand	Funded	2029	\$694,620	\$224,691	Local/FDOT Serv. Dev.	① ② ⑤
Add Sun. Service on Routes 1, 2, 3, and 4	Funded	2030	\$132,538	N/A	Local	① ② ⑤
Indian River Estates ART On Demand	Funded	2031	\$694,620	\$224,691	Local/FDOT Serv. Dev.	① ② ⑤
Add Saturday Service on Route 8	Funded	2031	\$79,523	N/A	Local	① ② ⑤
30-minute Frequency on Route 3	Funded	2033	\$351,450	\$600,000	Local	① ② ⑤
North St. Lucie ART On Demand	Funded	2033	\$694,620	\$224,691	Local/FDOT Serv. Dev.	① ② ⑤
Extend Weekday Service Span to 10 PM	Funded	2034	\$343,918		Local	① ② ⑤
Dual Enrollment Shuttle	Funded	2034	\$343,918	\$1,200,000	Local	① ② ⑤
Downtown/Passenger Rail Station/Beach Shuttle	Funded	2034	\$414,605	\$600,000	Local	① ② ⑤
Airport/College Express	Unfunded	Unfunded	\$257,939	\$600,000	Unfunded	① ② ⑤

Table 9-4: Reimagine Transit TDP Implementation Plan and Unfunded Needs / Capital

Improvements	Funding Status	Implementation Year (FY)	Annual Operating Cost (2025\$)	Total Capital Cost (2025\$)	Potential Revenue Source	TDP Goal/Objective
Bus Stop/Shelter Improvements	Funded	2025	N/A	\$100,000	FTA	① ② ③ ④ ⑤
Port St. Lucie Intermodal	Partially Funded	2025-2027	N/A	\$5,000,000	Local/FTA	① ② ③ ④ ⑤
Operations and Maintenance Facility	Partially Funded	2025-2029	N/A	\$30,000,000	Local/FTA	① ② ③ ④ ⑤
Fare Policy/Structure Evaluation Study	Funded	2026	N/A	\$300,000	Local	① ②
Expand Transit Marketing/Education Program	Funded	2026	N/A	\$100,000	Local	① ② ③ ⑤
TSP	Funded	2026-2033	N/A	\$25,000	Local/FTA	① ② ③ ④ ⑤
Queue Jumps	Funded	2026-2033	N/A	\$150,000	Local/FTA	① ② ③ ④ ⑤
Wi-Fi on Buses	Funded	2027-2034	\$25,000	\$100,000	Local	① ② ③ ⑤

Section 10. Coordination and Implementation

The goal of this TDP is to develop an implementable transit plan for ART that reimagines the current transit network, potentially making it a viable and accessible option to all. However, developing the *Reimagine Transit* plan and obtaining the approval of the decision-makers to implement the TDP are really only the first steps in a longer process of bringing the TDP to fruition.

The ultimate success of *Reimagine Transit* would require balancing of the technical challenges with the art of navigating the local funding and political landscapes. This balancing act necessitates that a transit agency and its partners develop and lean on their competence, consistency, and political acuity, as well as remaining highly resilient and able to absorb and successfully respond to both praise and criticism during the process.

To support transit agency and its partners make this transition and prepare them to maneuver through the challenges ahead as the TDP's recommendations evolve into implementable projects, this section provides useful tools/guidance for implementing TDP recommendations and integrating them into the agency's existing operations, as well as the planning fabric of the community and region. Starting at plan adoption, this section presents a set of actions for ART to ensure that the TDP is implemented, coordinated, and communicated in the coming months and years.

Implementation/Coordination Action Items

The following action items should be carefully considered and followed through to ensure that public support and funding and operational support are preserved until the next major TDP update:

- Securing/maintaining funding for the plan** - St. Lucie County has put forth significant efforts to improve and promote transit in the county by becoming fare-free. In discussions during the TDP outreach process, stakeholders were supportive of remaining fare-free and expanding to new service types. While the MSTU-based dedicated funding for transit has increased significantly, it should be managed well and maximized for leveraging other funding, so the benefits of this funding increase are maximized and maintained. Making sure the necessary funding is available each year to maintain and add any new services or facilities programmed in the TDP implementation plan is key to the success of this transit plan. While the TDP implementation schedule does not preclude ART the opportunity to delay or advance any projects, ART should put its best efforts into staying on schedule.

- **Engage regional partners** – FDOT’s commitment to enhancing mobility strategies to develop major connected corridors with transit operations, transforming passenger terminals into mobility hubs with a wide range of modal options, and first/last mile connections allows ART an opportunity to partner with FDOT to secure State and Federal funds to help support similar strategies in its TDP. ART should continue to identify potential grants and apply for funding to implement transit alternatives, and use the information provided in the TDP to develop project applications, including defining/describing the projects, justifying needs, providing service and operational parameters, outlining a proposed budget, and providing performance measures. In addition, discussions with FDOT on participating in the FDOT Commuter Services program on a new vanpool program should continue and may expand to other modes as well. It will be important to coordinate with regional transit agency partners as well, including PalmTran and Marty, for additional/enhanced opportunities for regional connections.
- **Build on TDP efforts and engage with the community** - Throughout the development process, the TDP has identified advocates and stakeholders while reaching out to the public for input and guidance on developing ART’s future needs. The agency should leverage these relationships to continue building support for the recommended improvements, especially those that may require strong support and buy-in from the community. Additionally, community engagement efforts should include working with appropriate agencies to ensure a holistic approach to both land use and transit. Interested agency personnel may serve as facilitators for a grassroots outreach program or could become transit ambassadors to raise awareness of existing services and additional support for new services. However, to assist these efforts, it is important that ART prioritize projects and strategies that align closely with and support the community’s vision and emphasize its commitment to be a good steward of public funds.
- **Boost awareness and motivate with the TDP** - The adopted TDP should be used as a tool to substantiate and explain the reasons for continued investments in transit services and capital needs. The return on investment from conducting this planning effort should span at least over the next five years until the next major update is undertaken. ART should capitalize on and continue to maximize community support whenever possible to realize the recommended implementation plan.
- **Develop and use a TDP Executive Summary as a marketing tool** - The *Reimagine Transit* TDP Executive Summary (when its developed after the TDP adoption) should be used as a promotional tool and an effective medium to continue generating support for the TDP’s recommendations. A concise document that includes only key information from the TDP may be more effective than distributing a large report with technical details for soliciting support from the general public and/or stakeholders. ART should share this Executive Summary as part

of marketing/awareness campaigns, targeting meetings, activities, and events to provide details of the planned transit growth and educate the community and leaders to keep the momentum of the TDP process fresh beyond the TDP adoption.

- **Inform and coordinate with other plans** - St Lucie TPO's efforts in preparing the transit element of its LRTP should be coordinated with the ART and leverage the alternatives and recommendations from Reimagine Transit TDP major update. Better timing and coordination of these plans can make the related analyses, outreach, and results far more valuable and productive for each plan. In addition, analyses completed during the TDP can be used to help update required plans for ADA access and Title VI service provisions, as they document how the system will serve older adults and populations that fall under Title VI protections. The adopted TDP can also be useful to other entities with subsequent planning efforts, such as local TD plans, comprehensive plans, area redevelopment plans, plans to develop affordable housing, and Florida's SIS Needs Plan.



Coco Vista Centre
 466 SW Port St. Lucie Blvd, Suite 111
 Port St. Lucie, Florida 34953
 772-462-1593 www.stlucietpo.org

AGENDA ITEM SUMMARY

Board/Committee:	Technical Advisory Committee (TAC)
Meeting Date:	May 21, 2024
Item Number:	6d
Item Title:	Advanced Air Mobility (AAM) Study Phase 2
Item Origination:	UPWP
UPWP Reference:	Task 3.6- Freight Planning
Requested Action:	Recommend acceptance of Phase 2 of the AAM Study, recommend acceptance with conditions, or do not recommend acceptance.
Staff Recommendation:	Because the proposed AAM concept aligns with the goals of the SmartMoves 2045 Long Range Transportation Plan, and Phase 2 of the Study further advances the AAM effort by providing a comprehensive evaluation and analysis of the potential vertiports in the TPO area, it is recommended that Phase 2 of the AAM Study be recommended for acceptance by the TPO Board.

Attachments

- Staff Report
- Draft AAM Phase 2 Study



Coco Vista Centre
 466 SW Port St. Lucie Blvd, Suite 111
 Port St. Lucie, Florida 34953
 772-462-1593 www.stlucietpo.org

MEMORANDUM

TO: Technical Advisory Committee (TAC)

THROUGH: Peter Buchwald
 Executive Director

FROM: Yi Ding
 Transportation Systems Manager

DATE: May 14, 2024

SUBJECT: Advanced Air Mobility (AAM) Study Phase 2

BACKGROUND

Advanced Air Mobility (AAM) is an air transportation system that moves people and cargo between places not currently or easily served by surface transportation or existing aviation modes. At a mature state, AAM will integrate revolutionary aircraft including Electrical Vertical Take-Off and Landing Vehicles (eVTOL) and Unmanned Aircraft Systems (UAS) into highly automated networks.

The emerging AAM technology is outpacing the development of the regulatory framework. Currently, there is limited AAM related guidance at the Federal, State, and local levels. In 2022, the St. Lucie TPO retained Kimley-Horn and Associates (KHA), one of the TPO's General Planning Consultants, to conduct a Drone Port/AAM Study Phase 1 which provided a preliminary review of the AAM industry and recommended potential opportunities for the TPO to integrate AAM into the future planning activities. To continue the effort, the AAM Study Phase 2 was included in Task 3.6, Freight Planning, of the FY 022/23 – FY 2023/24 Unified Planning Work Program (UPWP).

ANALYSIS

The attached AAM Study Phase 2 was again conducted by KHA. The first task of the study involved analyzing local consumer demand for AAM transportation. This analysis utilized the most up-to-date census data to

identify census tracts that exhibit the highest demand for AAM transportation and to gain a comprehensive understanding of the potential demand for AAM in the TPO area.

The second task included a preliminary site review of the Treasure Coast International Airport property as part of a preliminary vertiport site review and identified potential vertiport locations on Airport property.

The final step of the study consolidated the findings of the first two evaluations and developed a visualization of AAM operations in the TPO area. Two specific locations, Southern Groves Development Area and Treasure Coast International Airport, for vertiport integration were identified to generate basic travel metrics to provide context of how AAM integration could potentially benefit or impact the current transportation network in the TPO area.

The proposed AAM concept aligns with the goals of the SmartMoves 2045 Long Range Transportation Plan (LRTP) including Supporting Economic Activities and Providing Travel Choices.

RECOMMENDATION

Because the proposed AAM concept aligns with the goals of the SmartMoves 2045 LRTP, and Phase 2 of the Study further advances the AAM effort by providing a comprehensive evaluation and analysis of the potential vertiports in the TPO area, it is recommended that Phase 2 of the AAM Study be recommended for acceptance by the TPO Board.



May 2024
St. Lucie TPO AAM Phase II Study

Table of Contents

- Chapter 1. Introduction 3**
 - 1.1. Background on Advanced Air Mobility and Prior Studies from Port St. Lucie Transportation Planning Organization (TPO) 3
 - 1.2. Purpose of the Study 3
 - 1.3. Goals and Objectives 4
 - 1.4. Technical Advisory Committee (TAC) 5
- Chapter 2. Off-Site Demand Analysis 6**
 - 2.1. American Community Survey 6
 - 2.2. Replica© Data 6
 - 2.3. Study Boundary 7
 - 2.3.1. U.S. Census Tract in St. Lucie 7
 - 2.4. Inventory of Existing Data 8
 - 2.4.1. Population Density/Sq Mile 8
 - 2.4.2. Median Household Income 9
 - 2.4.3. Points of Interests – Pedestrian Shed 10
 - 2.4.4. High Commute Time to Work 14
 - 2.4.5. Origin-Destination Trip Count 15
 - 2.5. Evaluation of Data – GIS-based Demand Analysis 15
 - 2.5.1. Findings Summary 16
- Chapter 3. Preliminary Site Review – Treasure Coast International 21**
 - 3.1. Treasure Coast International Airport 21
 - 3.1.1. Runways 21
 - 3.1.2. FPR’s Airspace and Operating Procedures 22
 - 3.1.3. Landside Access 26
 - 3.2. Vertiport Standards 26
 - 3.2.1. Engineering Brief No. 105 26
 - 3.2.2. Vertiport Design and Geometry 26
 - 3.2.3. Vertiport Airspace 27
 - 3.2.4. Vertiport Support Facilities 28
 - 3.3. Site Review 29
 - 3.3.1. Vertiport Orientation 29

- 3.3.2. Landside Access 29
- 3.3.3. Vertiport / Runway Separation 29
- 3.4. Preliminary Sites 32
 - 3.4.1. Initial Review of Preliminary Sites 33
 - 3.4.2. Vertiport Airspace Obstacle Analysis 34
 - 3.4.3. Integration into Airport Operations 35
 - 3.4.4. Landside Considerations 36
 - 3.4.5. Preliminary Site Determination 37
- 3.5. Assumptions and Limitations 38
- Chapter 4. Airspace and Infrastructure Modeling 39**
 - 4.1. Airports in St. Lucie 39
 - 4.2. Airspace Structure Overview 40
 - 4.2.1. Controlled Airspace 40
 - 4.2.2. Uncontrolled Airspace 40
 - 4.3. Airspace Above St. Lucie 40
 - 4.3.1. Existing Airways and Routing Above St. Lucie 41
 - 4.4. AAM Corridors 42
 - 4.5. Final Recommendation – Conclusion 43

Chapter 1. Introduction

1.1. Background on Advanced Air Mobility and Prior Studies from Port St. Lucie Transportation Planning Organization (TPO)

Advanced Air Mobility (AAM) is an air transportation system that moves people and cargo between local, regional, intraregional, and urban places previously served or underserved by aviation. At a mature state, AAM will integrate revolutionary aircraft including Electrical Vertical Take-Off and Landing (eVTOL) aircraft, Short Take-Off and Landing (STOL) aircraft, Unmanned Aircraft Systems (UAS) or drones, fixed-wing aircraft, and helicopters into highly automated networks. Currently, the new AAM technology is outpacing the development of the regulatory framework with limited AAM-related guidance at the federal, state, and local levels. As such, the St. Lucie Transportation Planning Organization (TPO) is independently seeking to learn more about this emerging industry and explore the possible integration of AAM into the region.

Prior to this study, the TPO has undertaken an initiative as part of its FY 2022/23 Unified Planned Work Program (UPWP) to gain a deeper understanding of the emerging industry. This effort has resulted in the creation of the ***Drone Port/Advanced Air Mobility Preliminary Review***, completed in 2022. This study provides recommendations and outlines potential opportunities for TPO to support the integration of AAM into the TPO area as depicted in **Figure 1** below.

Figure 1 – St. Lucie TPO AAM Integration Roadmap

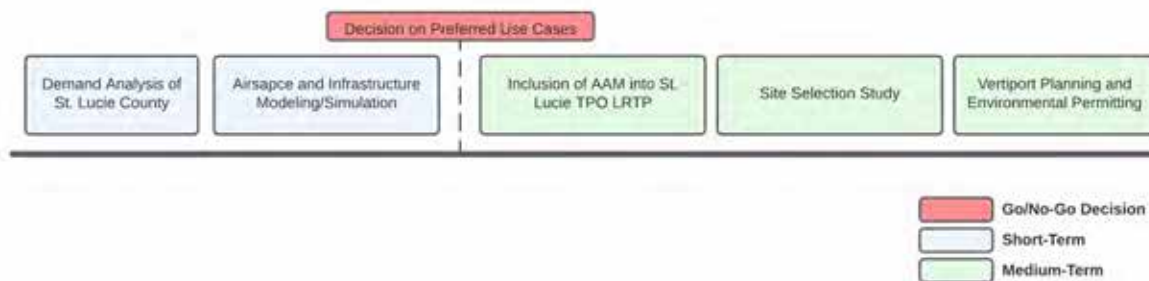

Source: *Drone Port/Advanced Air Mobility Preliminary Review*, St. Lucie TPO 2022

To further advance the AAM effort, TPO has taken the initiative as part of its FY 2023/24 UPWP to make progress on the short-term action items identified in **Figure 1** above, specifically the demand analysis of St. Lucie County and airspace/infrastructure modeling (the blue cells in the above figure). These studies will now be referred to as Phase 2 studies going forward and this technical memorandum provides a summary of the findings from Phase 2. As this technical memorandum does not include general information regarding AAM, readers are encouraged to refer to the TPO's ***Drone Port/Advanced Air Mobility Preliminary Review*** for a better understanding of the AAM system.

1.2. Purpose of the Study

The purpose of this study was to conduct a short-term evaluation as outlined in the roadmap. This evaluation included analyzing potential vertiport locations in the TPO area, assessing the suitability of on-

airport locations at Treasure Coast International Airport (FPR), and modeling and simulating airspace in the St. Lucie County based on the findings of the first two evaluations.

It is important to note that this study does not consider cargo use cases for vertiports, as companies like Amazon Prime Air and Wisk have expressed their intention to deliver goods directly from warehouses to customers' homes. Therefore, location of the cargo use case vertiport would primarily be driven by the existing or planned warehouse locations of delivery and Ecommerce companies. Conversely, the passenger use case requires a last-mile connection to consumers' final destinations. Indicating that location of the destination vertiport is crucial for the users as it impacts the cost of last-mile transportation, time savings, and overall convenience for users of AAM.

The initial task of the study involved analyzing off-site demand to assess local consumer demand in AAM transportation. This analysis utilized anonymous location-based primary trip data and the most up-to-date census data (2020)—such as average commute time to work, median household income, and population density—to identify two census tracts that exhibit the highest demand for AAM transportation, and to gain a comprehensive understanding of the potential demand for AAM in the TPO area.

The second task included a preliminary site review of the Treasure Coast International Airport property as part of a preliminary vertiport site review. The analyses listed below were performed as part of this study, and three (3) potential vertiport location on Airport property were identified as a result of these analyses. Given the limited scope of the study, it is important to acknowledge that the findings generated were preliminary. Therefore, it is recommended that a comprehensive review be conducted by the TPO or the Airport Sponsors prior to integrating a vertiport infrastructure into the FPR.

1. Integration into airspace/airport operations: performed cursory airspace analysis to identify clearance requirements and potential obstacles (e.g., buildings, towers, vegetation) to future vertiport imaginary surfaces, including obstacle clearance surfaces and Part 77 surfaces. This analysis utilized obstacle data provided by the Airport (if applicable), the Airport's most recent FAA-approved airport layout plan (ALP), data from the FAA's Obstruction Evaluation/Airport Airspace Analysis (OE/AAA) database, and/or the Consultant's knowledge of the project area. As part of this analysis, the vertiport approach, departure, and transitional surfaces, as published in Engineering Brief (EB) 105 and Title 14 Code of Federal Regulations (CFR) Part 77, respectfully, were evaluated to determine eVTOL ingress/egress clearance requirements, and potential obstacles. A review of the Airport's approach and departure procedures, traffic flow, and the surrounding airspace was also included.
2. FAA separation standards: reviewed FAA separation standards for aircraft operations, utilizing guidance published in EB 105, FAA Advisory Circular (AC) 150/ 5300-13B – Airport Design, and FAA Order JO 7110. 65 – Air Traffic Control.
3. Potential for future vertiport infrastructure and expansion possibilities: reviewed Airport property to identify three (3) area that may be used for future vertiport and related development.

The final step of the project consolidated the findings of the first two evaluations and developed a visualization of AAM operations in the TPO area. Two specific locations for a vertiport integration were identified to generate basic travel metrics to provide context of how AAM integration could potentially benefit or impact the current transportation network in the TPO region.

1.3. Goals and Objectives

The goals and objectives of this study integrated the goals of the Federal, State, and the TPO's Long Range Transportation Plan (LRTP), **SmartMoves 2045**, which aims to provide the public with a safe and efficient multimodal transportation system. The LRTP goals are as follows:

1. Support Economic Activities
2. Provide Travel Choices
3. Maintain the Transportation system
4. Provide Equitable, Affordable, and Sustainable Urban Mobility
5. Improve Safety and Security

Source: SmartMoves 2045, St. Lucie TPO 2021

While no specific performance measures were considered in this analysis, the above LRTP goals guided the decision-making process throughout the study in order to establish an outcome that promotes a safe and efficient transportation system while also preserving equity of the community members in the TPO area.

1.4. Technical Advisory Committee (TAC)

A Technical Advisory Committee (TAC) was established to provide ongoing guidance and support throughout the project. These members offered local, regional, statewide, and national insights on various issues affecting the AAM industry. Throughout the process, the TAC members were consulted and engaged, providing feedback on the usefulness and effectiveness of each study task. The TAC consisted of stakeholders with extensive knowledge and experience in traditional aviation, AAM, transportation, and related fields. The following organizations were represented by the TAC:

- Federal Aviation Administration (FAA)
- Florida Department of Transportation (FDOT)
- St. Lucie Transportation Planning Organization
- City of Fort Pierce
- City of St. Lucie
- Treasure Coast International Airport

Chapter 2. Off-Site Demand Analysis

The off-site suitability analysis identified two (2) sites for vertiport integration in the TPO area that exhibit the highest demand for passenger use. This analysis utilized the most up-to-date census data (2020) — such as average commute time to work, median household income, and population density—to identify two census tracts that exhibit the highest demand for AAM transportation, and to gain a comprehensive understanding of the potential demand for AAM in the TPO area. Various data sources evaluated as part of the analysis are discussed below.

2.1. American Community Survey

The U.S. Census Bureau conducts the American Community Survey (ACS) annually to gather demographic information. This survey collects data that was previously only included in the long form of the decennial census, such as ancestry, citizenship, education, income, language proficiency, migration, disability, employment, and housing characteristics. Data generated from the survey are widely utilized by various stakeholders in the public, private, and nonprofit sectors for purposes such as funding allocation, tracking demographic changes, emergency planning, and transportation planning. The survey is sent to approximately 295,000 addresses each month, making it the largest household survey administered by the U.S. Census Bureau. In the context of this study, the ACS data provided metrics that were identified as a proxy towards transportation demand for each census tract in the TPO area.

2.2. Replica© Data

In addition to the ACS survey, this project utilized Replica© data to gain a better understanding of existing travel patterns in the TPO area. Replica© is a tool that utilizes credit card transactions and other anonymous location-based sources, providing primary trip data for market and transit assessments. Data from September 2022 to January 2024 was collected and provided insights into various aspects of trips such as purpose, length, duration, mode of transportation, and start and end times. Replica© also provided anonymized data on trip takers, including household income, age, race and ethnicity, approximate home, work, and school locations, and employment status; it also differentiated between trips taken by visitors and full-time residents in TPO area. In the context of this study, data variables such as origin and destination pairing, trip purpose, and other data sets were utilized to help better understand the travel trends and emerging market opportunities for AAM in the TPO area.

2.3. Study Boundary

Started after the 1980 Census, the St. Lucie TPO is a Metropolitan Planning Organization (MPO) responsible for the planning and programming of State and Federal funding for transportation improvements for the City of Fort Pierce, City of Port St. Lucie, St. Lucie Village, and the unincorporated areas of St. Lucie County. Therefore, the AAM study boundary is the same as TPO's jurisdiction boundary as depicted below.

Figure 2 – St. Lucie TPO Boundary

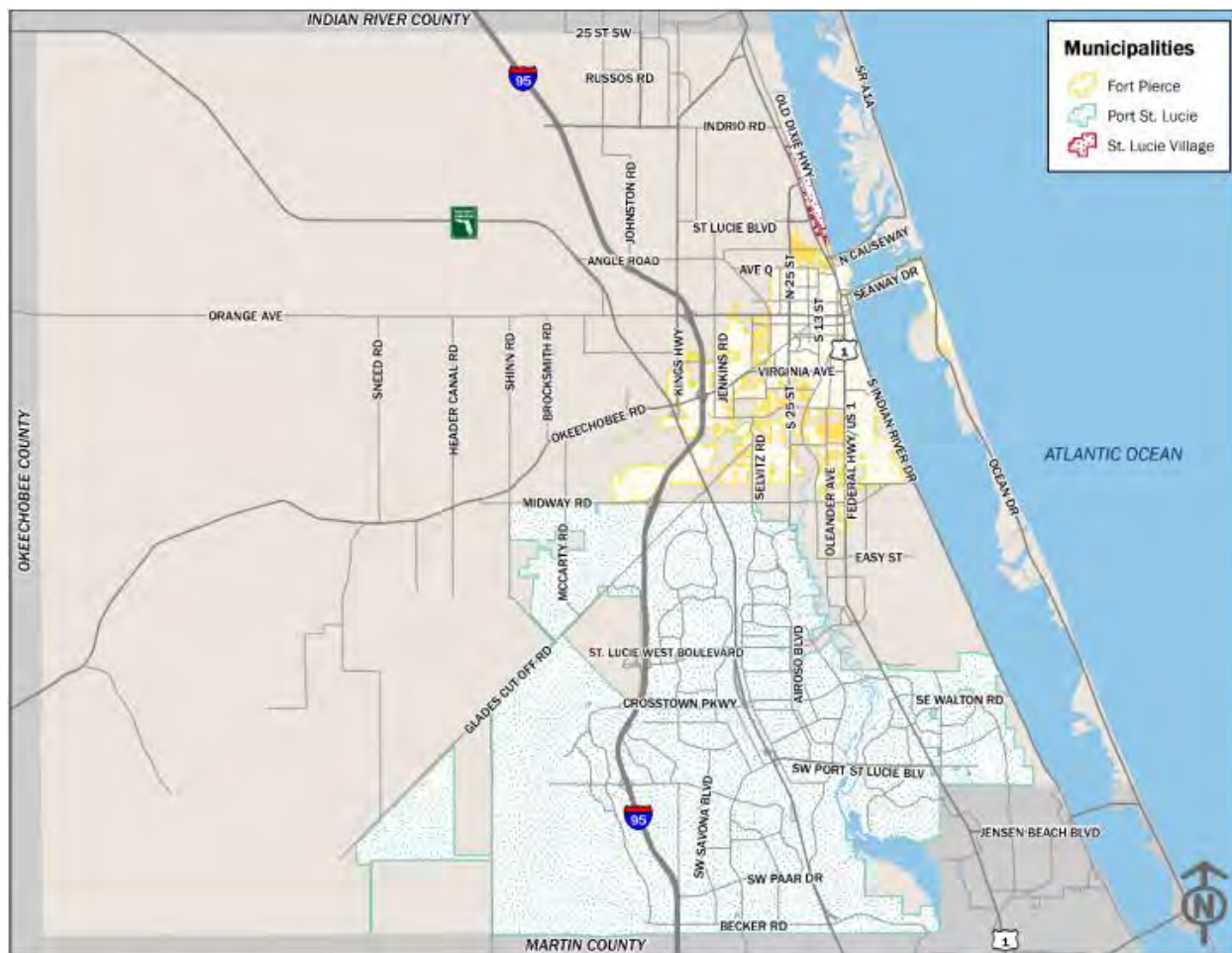

Source: SmartMoves 2045, St. Lucie TPO 2021

2.3.1. U.S. Census Tract in St. Lucie

Establishing a common boundary is crucial to the assignment of unique variables that are associated with each boundary, and there are multiple geographic units available for the purpose of tabulating data. While there are numerous ways to delineate a region, presented below are geographic units that are commonly used in this type of study.

U.S. Census Tract (Recommended) – A small, relatively permanent statistical subdivision of a county delineated by a local committee of census data users for the purpose of presenting data. Census tract boundaries normally follow visible features but may follow governmental unit boundaries and other non-visible features. Census tracts always nest within counties. Designed to be relatively homogeneous units with respect to population characteristics, economic status, and living conditions at the time of

establishment, census tracts average about 4,000 inhabitants. They may be split by any sub-county geographic entity.

U.S. Census Block – A subdivision of a census tract (or, prior to 2000, a block numbering area), a block is the smallest geographic unit for which the Census Bureau tabulates 100-percent data. Many blocks correspond to individual city blocks bounded by streets, but blocks – especially in rural areas – may include many square miles and may have some boundaries that are not streets. The U.S. Census Bureau established blocks covering the entire nation for the first time in 1990. Previous censuses back to 1940 had blocks established only for part of the nation. Over 8 million blocks are identified for Census 2000.

When leveraging census tract data, it is important to acknowledge that each census tract varies in size, thereby resulting in disparities in data concentration. Therefore, some metrics evaluated need to be divided into a standardized format such as per square mile.¹

2.4. Inventory of Existing Data

This section provides an overview of the variables that were assessed for each census tract in the TPO area. The purpose of this inventory was to establish an individual understanding of each data variable that was evaluated comprehensively in section 2.5 using GIS-based suitability analysis. It is important to acknowledge that these variables may not be the sole factors influencing the demand for a vertiport facility. Other factors—such as land availability, airspace regulations, and local patterns that could not be measured/quantified at the time data was collected for this report—may need to be considered in the future when defining a more specific location beyond a census tract level.

2.4.1. Population Density/Sq Mile

Population density is an important variable to consider when determining the suitability of a vertiport location in a region. The number of people residing within a given area is often indicative of the demand for transportation services. Higher population density typically corresponds to a greater concentration of transportation service demand. In addition to being a demand proxy, selecting a vertiport location in an area with high population density ensures that it will be easily accessible to a large number of individuals. It is important to note that when analyzing population data, it is necessary to account for disparities in data concentration. As such, population count for each census tract are divided by the corresponding census tract's area to generate population density that is defined per square mile. **Figure 3** depicts population density of each census tract within the St. Lucie TPO boundary where values range from below 1,000 to over 4,000 people per square mile.

¹ For instance, consider block group A, which encompasses an area of 10 square miles with a population of 10 inhabitants. This would yield a 1 population density per square mile, which is the same population density value for block group B, which spans an area of 20 square miles with a population of 20 inhabitants.

Figure 3 – Population Density

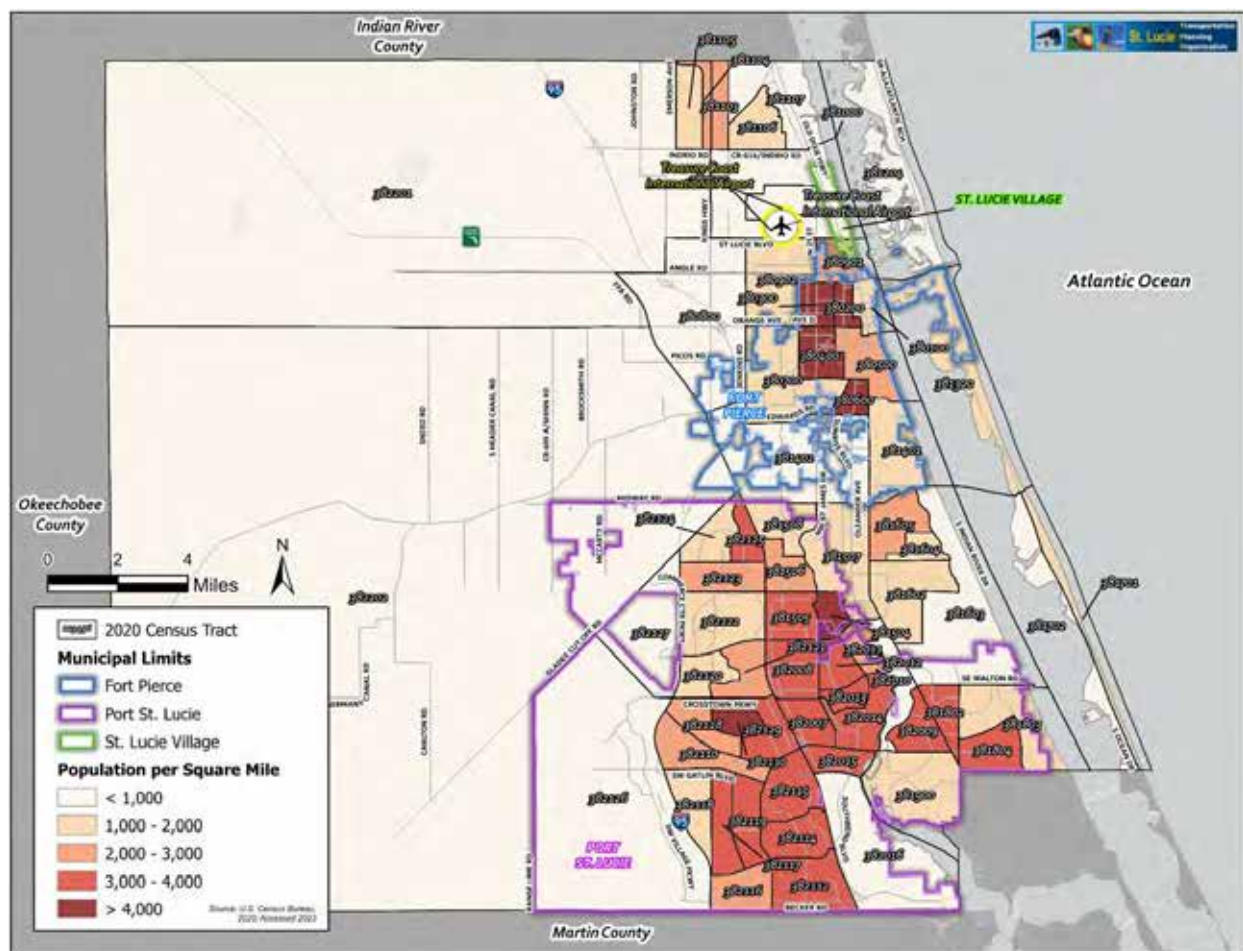

Source: U.S. Census Bureau, 2020

Figure 3 indicates that there are concentrated areas (Census Tract# 380200, 380400, and 380600) of high population density in downtown Fort Pierce and in the residential areas (Census Tract# 382130 381504) of the City of Port St. Lucie. The census tract in Fort Pierce near the downtown region is the most dense with 4,905 of inhabitants per square mile, while the non-incorporated regions and St. Lucie Village generally reported a lower population density compared to the region's average.

2.4.2. Median Household Income

Median household income can serve as a proxy for AAM transportation demand. A higher average income suggests that households have more disposable income to spend on convenience and time saving benefits. Being a new mode of travel, AAM is expected to have a higher cost during its infancy compared to traditional transportation alternatives. Households with higher incomes are more likely to be the early adopters of AAM services. **Figure 4** depicts relative percentile groups of median household incomes for each census tract within the St. Lucie TPO boundary. The median household income value ranged from below \$20,000 to slightly above \$100,000 in the past 12 months.

Figure 4 – Median Household Income

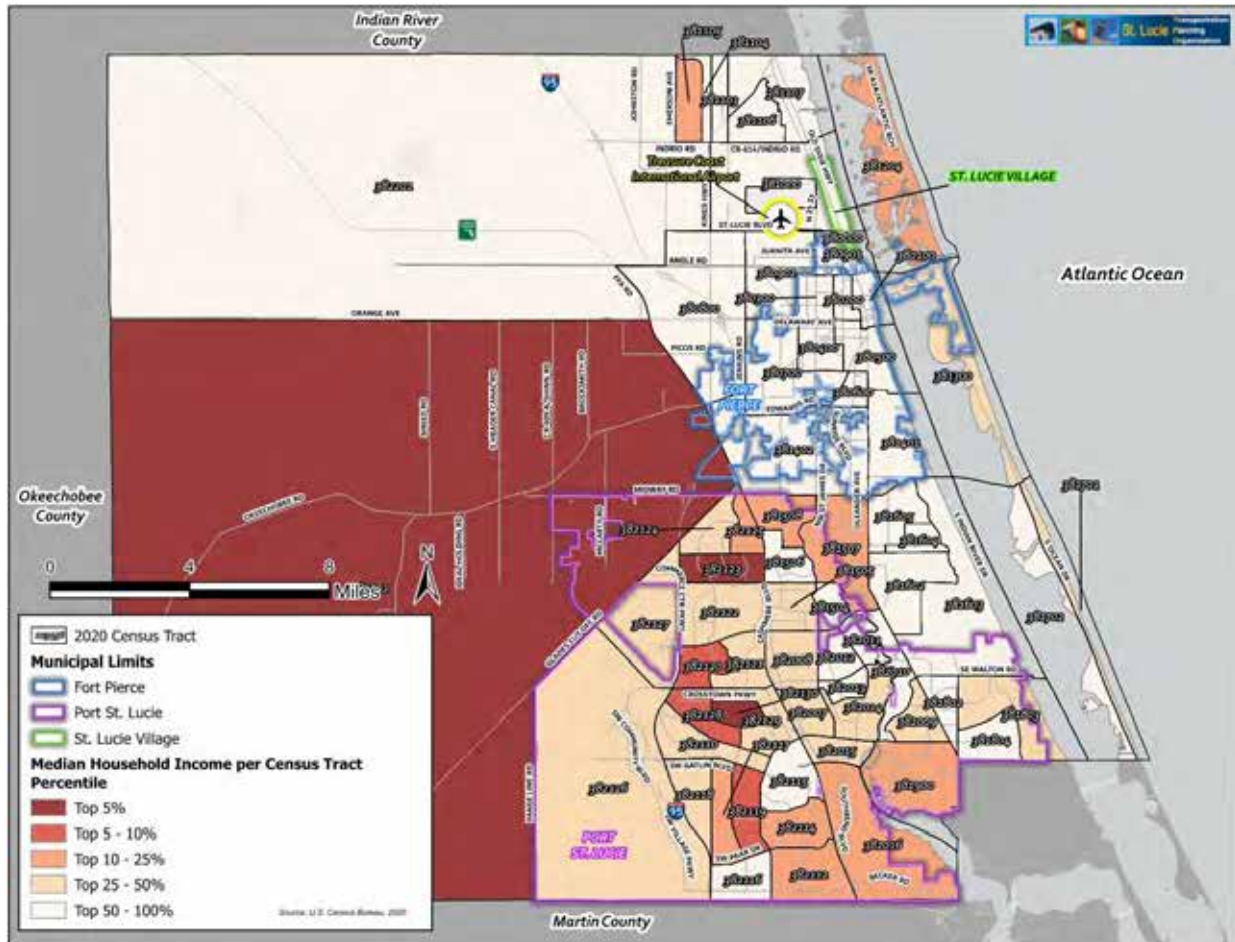

Source: U.S. Census Bureau, 2020

The median household income in the past 12 months is evenly distributed throughout the region, with lower than average incomes reported in the tracts located along the eastern part of the City of Fort Pierce, particularly in the downtown area. The highest median highest household income in the top 5% percentile was reported as \$102,000 in Census Tract# 382123.

2.4.3. Points of Interests – Pedestrian Shed

Points of interest (POI) can serve as a reliable proxy for transportation demand when determining the placement of vertiport infrastructure. These locations—such as commercial developments, tourist attractions, sports stadiums, entertainment venues, etc.—attract a significant concentration of people, indicating a high potential for transportation needs for users of these facilities to get to and from these points of interests. Transportation planning strategically places transit facilities near these points of interest to be able to capture the demand generated by these areas and provide convenient access through AAM transportation services.

Additionally, highly accessed locations often have well-established transportation infrastructure, including roads, highways, and public transit stations. Leveraging this existing infrastructure can enhance last-mile connectivity between the vertiports and other modes of transportation, creating a seamless and efficient transportation network. By capitalizing on the accessibility and central location of points of interest in the

TPO area, AAM can efficiently serve the transportation needs of both residents and visitors, further improving the time saving benefits and the overall passenger experience.

For this evaluation, a preliminary list of the 30 most popular points of interest (POIs) within the study boundary was collected through published sources such as VISIT Florida, St. Lucie website, and the SmartMoves 2045 Long Range Transportation Plan (LRTP). This list was then reviewed and refined by the TAC members during the first committee meeting on February 28, 2024. The final POIs include city centers, beaches, intercity bus facilities, parks, museums, entertainment venues, lodging options, golf courses, stadiums, as well as proposed job opportunity areas for large-scale manufacturing, logistics and retail development (Southern Grove Development). **Table 1** below presents the complete list of POIs utilized as part of this analysis.

Table 1 – Points of Interests in St. Lucie County

Facility Name	Jurisdiction	Type
Blind Creek Beach	Fort Pierce	Beach
Downtown Marina Square	Fort Pierce	City Center
Fort Pierce Inlet State Park	Fort Pierce	Beach
Fort Pierce Station "Dunkin Donuts"	Fort Pierce	Intercity Bus Facility
Fort Pierce Station "Loves Travel Stop"	Fort Pierce	Intercity Bus Facility
Frederick Douglass Memorial Park	Fort Pierce	Beach
Heathcote Botanical Gardens	Fort Pierce	Park
Jetty Park	Fort Pierce	Beach
Navy Seal Museum	Fort Pierce	Museum
Pepper Park Beach	Fort Pierce	Beach
South Beach Park	Fort Pierce	Beach
South Causeway Beach	Fort Pierce	Beach
Sunrise Theater	Fort Pierce	Entertainment
Surfside Park	Fort Pierce	Park
Fairwinds Golf Club	Fort Pierce	Lodging/Golf
Clover Park	Port St. Lucie	Stadium
Fort Pierce/Port Saint Lucie Service Plaza	Port St. Lucie	Intercity Bus Facility
Hilton Garden Inn PGA Village	Port St. Lucie	Entertainment
MIDFLORIDA Event Center	Port St. Lucie	Venue
PGA Village	Port St. Lucie	Entertainment
Port Saint Lucie Station "Shell Gas Station"	Port St. Lucie	Intercity Bus Facility
Port Saint Lucie Station "Sunoco Gas Station"	Port St. Lucie	Intercity Bus Facility
Port St. Lucie Botanical Gardens	Port St. Lucie	Park
Sandpiper Bay Resort	Port St. Lucie	Lodging/Golf
Savannas Preserve State Park	Port St. Lucie	Park
The Saints of Port St. Lucie	Port St. Lucie	Entertainment
Tradition Village Center	Port St. Lucie	Entertainment
Port District	Port St. Lucie	Entertainment
McCarty Ranch Preserve	Port St. Lucie	Park
Florida Sports Hall of Fame	Port St. Lucie	Museum
Oxbox Eco-Center	Port St. Lucie	Park
River Lilly Cruises	Port St. Lucie	Park
Indian River State College	Port St. Lucie	School
Southern Grove – Industrial Area	Port St. Lucie	Industrial Area
Southern Grove – Cultural Arts/Entertainment	Port St. Lucie	Cultural Arts /Entertainment
Southern Grove – Main Street/Office	Port St. Lucie	Main Street/Office

Figure 5 – Points of Interest in St. Lucie County



In addition to the attraction POIs that generate transportation demands to the region, there are also POIs such as transit facility that relieve transportation demands to and from the region and can be a suitable vertiport location. These transit facilities would enhance multi-modality and provide convenient last-minute connections to and from the vertiport. Furthermore, there are proposed developments that do not currently exist, but were taken into consideration. These developments indicate a potential shift in transportation demand; they also provide opportunity for better coordination and integration of the vertiport infrastructure and amenities to ensure that the vertiport is seamlessly woven into the fabric of the overall development, which would create a more cohesive and functional environment. Two specific locations in St. Lucie TPO region—the Fort Pierce/Port Saint Lucie Service Plaza and the proposed Southern Grove Development—are explored further below.

- Fort Pierce/Port Saint Lucie Service Plaza** - Florida's Turnpike Mainline has eight service plazas located approximately every 40 miles. These plazas are open 24/7 and offer various dining options, gift shops, ATMs, public telephones, travel information, dog walks, and other amenities. The main advantages of hosting a vertiport facility in the vicinity of a service plaza are its amenities, the proximity to the turnpike, and the open space nearby that may be more suitable for vertiport's airspace and land use integration.
- Southern Grove Development** - Southern Grove is one of Florida's unique job opportunity areas for large-scale manufacturing, logistics and retail development. It has the largest swath of development-ready vacant land in all South Florida that fronts over four miles of Interstate 95, with interchanges at both Tradition Parkway and Becker Road. Port St. Lucie has a talent-ready labor market with a central location between several major metro areas, including international airports located in Orlando and West Palm Beach. It is an

opportunity for development with the city of Port St. Lucie with over 10 million square feet of office, industrial, warehouse, and retail space. Parcel sizes are flexible to allow opportunities for large-footprint users. Potential development include manufacturing, distribution, warehousing, corporate office, medical office, research and development, retail, multi-family residential, hospitality and educational uses.

The analysis applied a pedestrian “Shed” with a radius of ¼-mile to each of the POIs.² This is because simply counting the number of POIs in each census tract may not provide an accurate representation of their proximity to surrounding tracts. It is possible that a POI may be more easily accessible from a different census tract rather than from the opposite end of the tract it is located within. **Figure 6** presents the ranking of each census tract based on the number of POI pedestrian shed are contained within them.

Figure 6 – Points of Interests

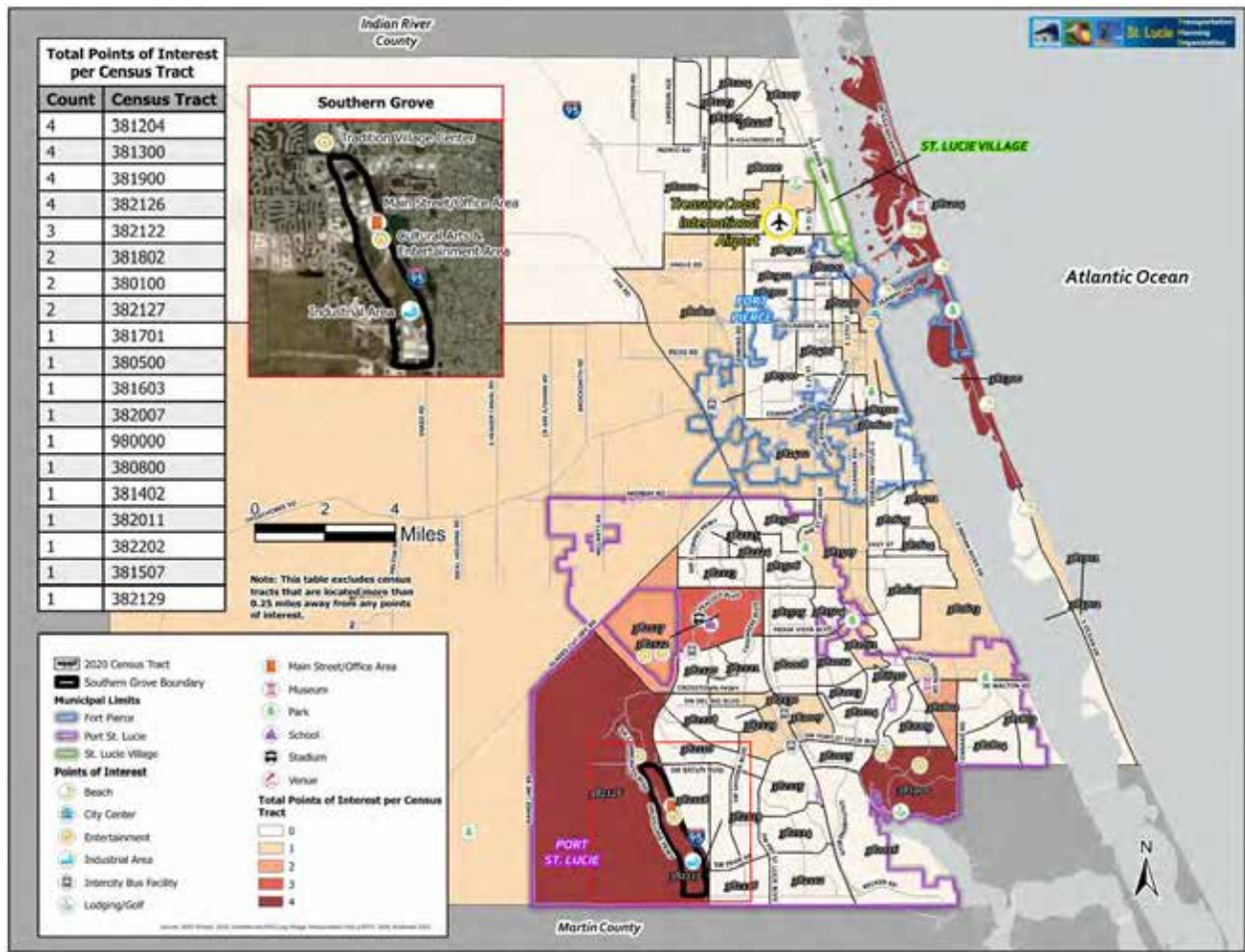

Source: U.S. Census Bureau, 2020

Figure 6 indicates that there are several census tracts that have a high concentration of POIs.

² ¼ mile is what is commonly accepted as the typical distance people are willing to walk.

2.4.4. High Commute Time to Work

High commute time to work serves as a valuable indicator of passenger demand towards transportation and time-saving benefits. When commuters experience long commute times, it often can be tied to a stronger desire to explore alternative transportation options to reduce travel time. AAM has the potential to significantly decrease commute times by bypassing traditional road congestion and utilizing direct flight paths. Therefore, areas with above-average commute times can be considered potential hotspots for AAM services, as individuals in these locations are likely to be motivated to seek alternative transportation to shorten their commutes. Additionally, high commute times can also be attributed to inadequate transportation infrastructure in a particular area, further contributing to the potential demand for AAM services to enhance transportation efficiency. In the context of AAM, this suitability analysis focuses on the percentage of workers whose commute exceeds 45 minutes within a census tract. Any commute time less than 45 minutes is not considered an appropriate proxy for AAM, as the time-saving benefits yielded from AAM are not expected to be significant. **Figure 7** depicts the percent of workers whose commute was 45 minutes or more per census tract within the study boundary.

Figure 7 – Commute Time to Work

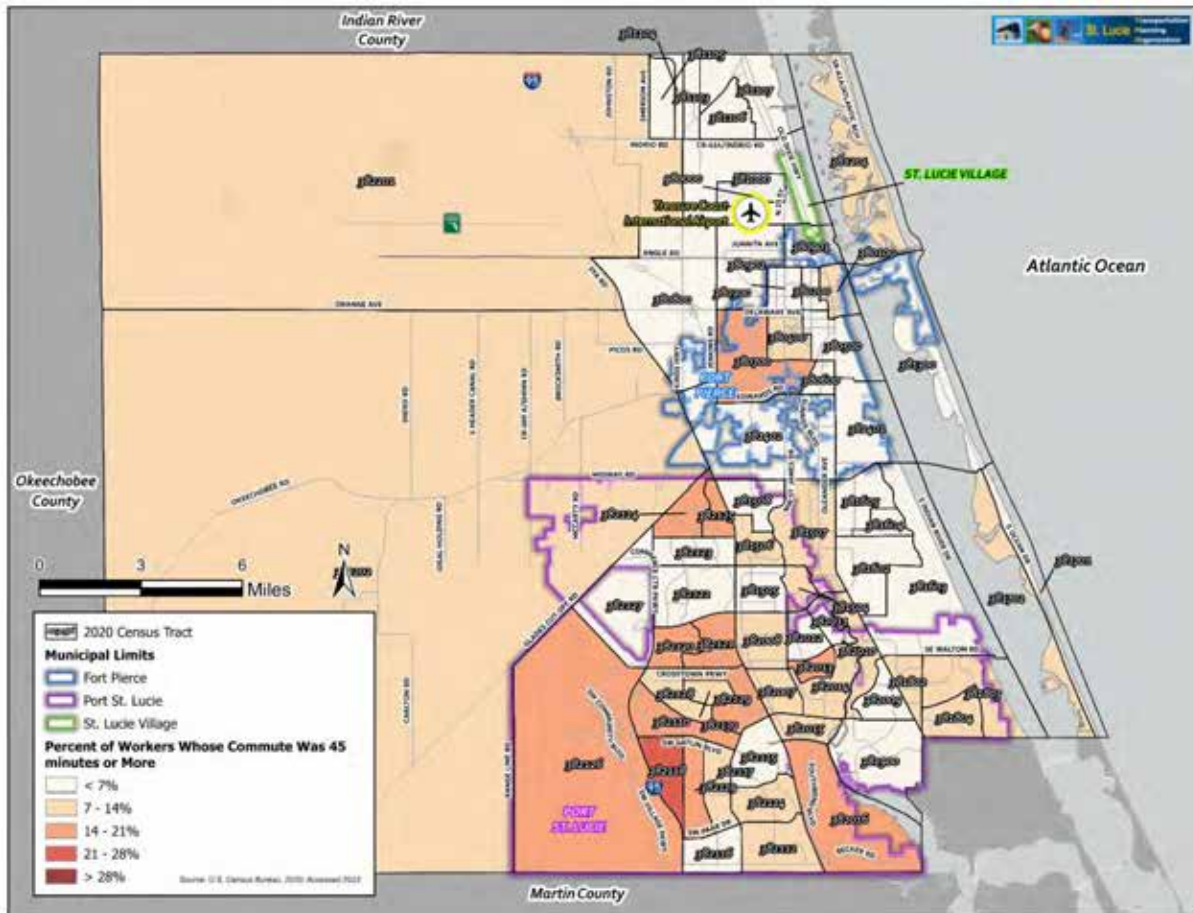

Source: U.S. Census Bureau, 2020

Figure 7 indicates that the percentage of workers whose commute was 45 minutes or more is higher in southern Port St. Lucie area compared to other areas within the study boundary; census tract# 382118 has the highest percentage at 25% of workers with commute times over 45 minutes.

2.4.5. Origin-Destination Trip Count

Origin and destination (O&D) trip count is a direct indication of transportation demand, which accounts for all transportation related activities in each census tract. This data utilizes credit card transactions and other anonymous location-based sources, and provides primary trip data for market and transit assessments. For this project, this data is sourced from Thursdays and Saturdays in the fall of 2023, and provides insights into various aspects of trips such as purpose, length, duration, mode of transportation, and start and end times.

Figure 8 – Origin-Destination Trip Count

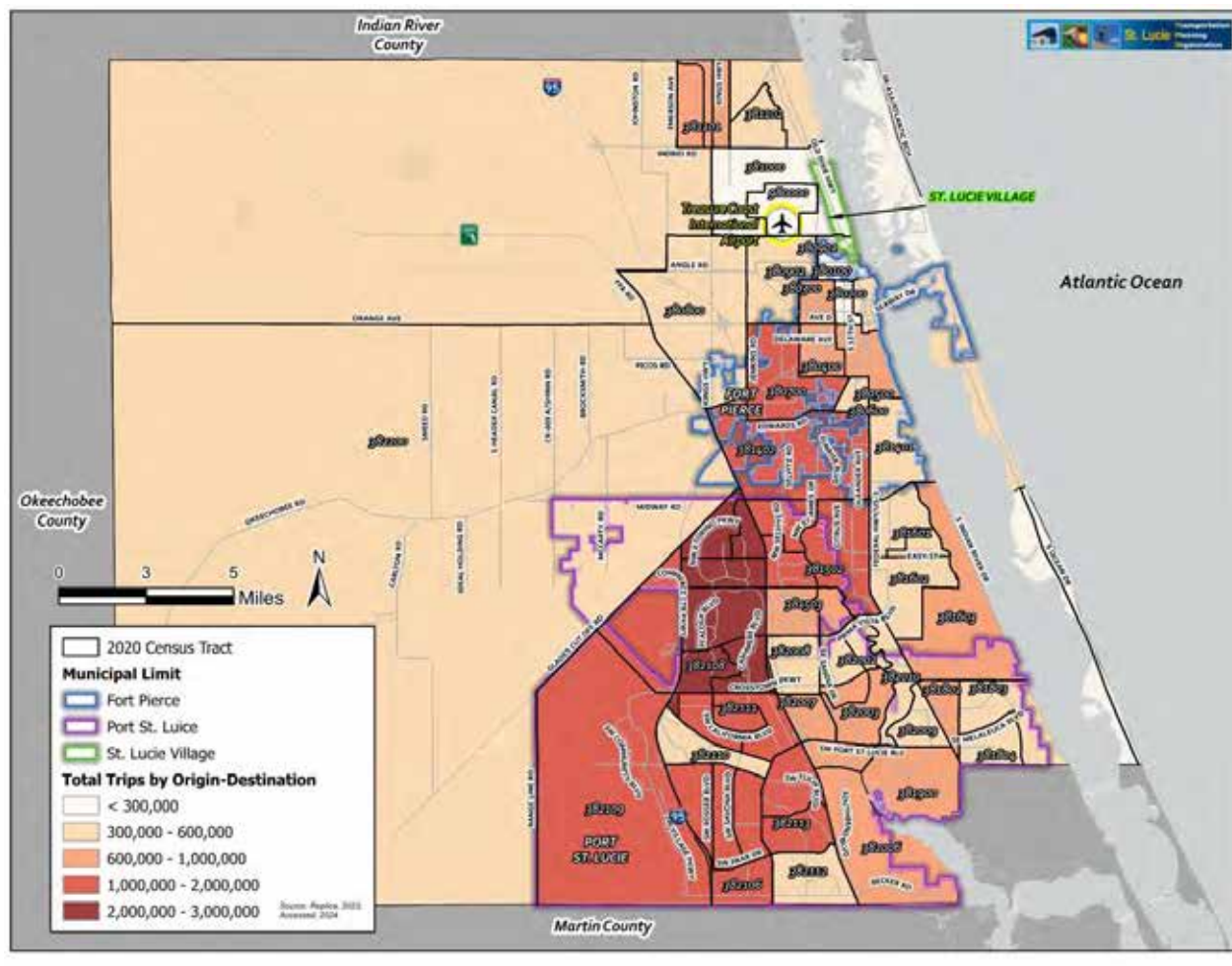

Source: U.S. Census Bureau, 2020

Figure 8 indicates that the highest concentration of O&D trip count was recorded in the region of Port St. Lucie West.

2.5. Evaluation of Data – GIS-based Demand Analysis

The final step of the analysis involved assigning a score to each census tract based on a scoring system developed for each of the variables. The scoring system ranged from 1 – 5 points for a specific variable—depending on how a given census tract performed when compared to other census tracts in the TPO area—with a score of 5 being more favorable than a score of 1. For instance, a census tract with a top 5% median

household income received 5 points, while a lower census tract in the bottom percentile received a lower score. The purpose of developing this scoring system was to incorporate the scores into a comprehensive suitability analysis that combined all the variables’ associated scores in order to calculate a comprehensive ranking. In addition, the Analytical Hierarchy Process (AHP) was utilized to incorporate the community’s vision into the overall process. The AHP process involves surveying participants using pairwise comparisons to quantify individual opinions and establish measurable numeric relationships/prioritization between each of the variables. This process ultimately defined specific weights that were applied to each of the variables used for the GIS-based demand analysis. The TAC members were presented with the individual variables discussed in the previous section, and surveyed using the AHP process.³ The AHP survey results of the TAC members were averaged to determine the collective prioritization of variables for analyzing AAM transportation demand in the TPO area. **Table 2** below depicts the average weights each of the variable, which contributed to the final suitability analysis.

Table 2 – AHP Survey Result

Population Density	Average Commute Time to Work	Median Household Income	Trip Counts	Points of Interests
14%	20%	38%	19%	9%

Note: The AHP Survey result represents the average opinions of all seven TAC members. This survey was conducted during the first committee meeting on February 28, 2024.

2.5.1. Findings Summary

Figure 9 indicates that Census Tract# 382123 and 382130 are the two census tracts that exhibited the highest AAM Demand in the TPO area. The subsequent section provides more in-depth analytics of these two census tracts.

³ An example AHP survey can be accessed from the following link. <https://bpmsg.com/ahp/ahp-calc.php?n=5&c%5B0%5D=Population+Density&c%5B1%5D=Average+Commute+Time+to+Work&c%5B2%5D=Median+Household+Income&c%5B3%5D=Trip+Counts&c%5B4%5D=Points+of+Interests>

Figure 9 – Two Highest Demand Census Tracts

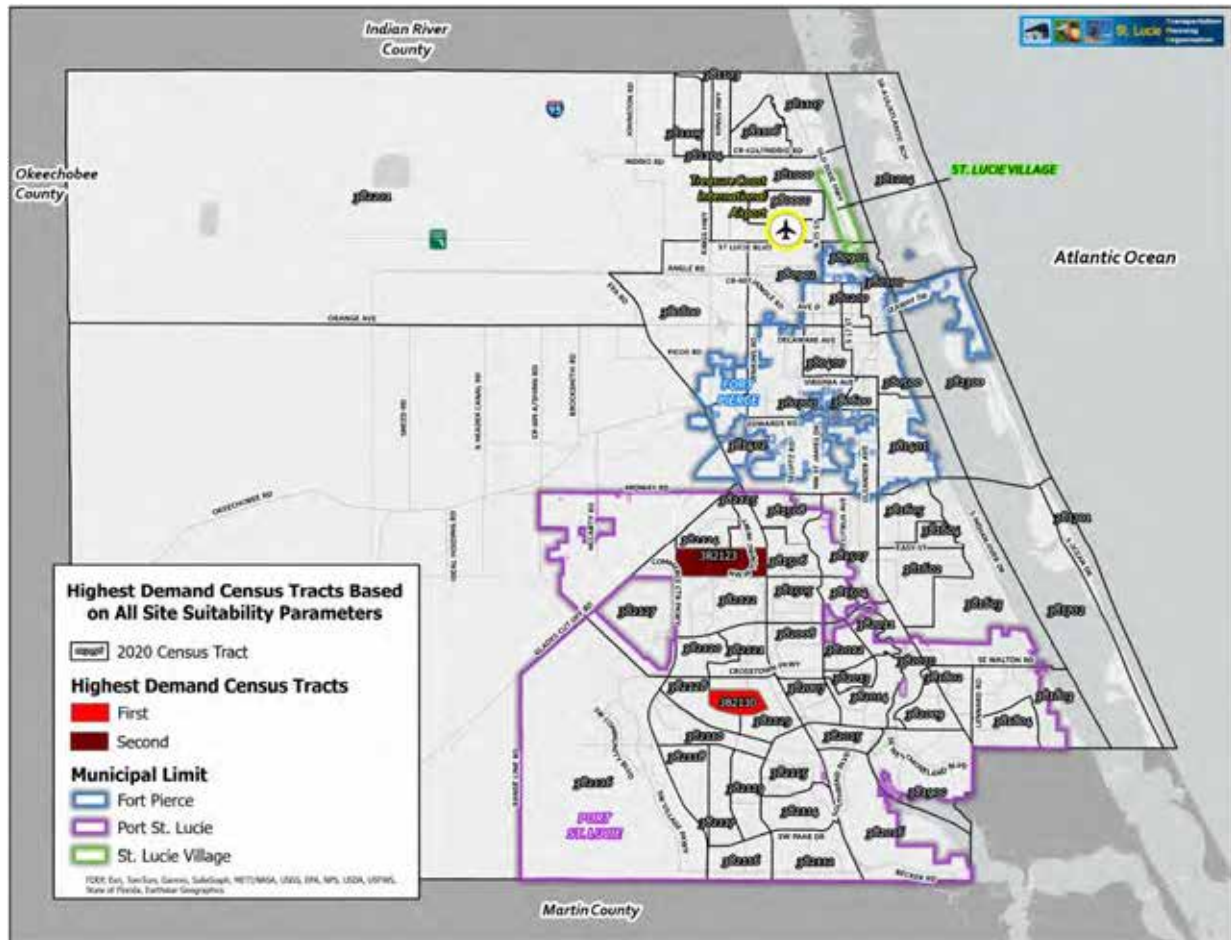

Source: U.S. Census Bureau, 2020

#1 - Census Tract # 382130 – Located in the central area of Port St. Lucie, this census tract exhibited high demand in terms of population density and median household income. Although there were no points of interest directly located within, there are various types of entertainment, retail, industrial, and transit facility POIs in close proximity to the census tract within the 3-mile buffer.

- **Population Density** – 5 out of 5 points with 4,196 person per square mile
- **Average Commute Time to Work** – 2 out of 5 points with 11.4% of workers whose commute was 45 minutes or more
- **Median Household Income** – 5 out of 5 points with \$95,443 median household income.
- **Trip Counts** – 4 out of 5 points with 1.8 million origin and destination trips.

Points of Interests – 0 out of 5 points with 0 POIs located inside the census tract.

#2 – Census Tract # 382123 – Located in the northern area of Port St. Lucie, this census tract exhibited high demand in terms of median household income and trip counts. Although there were no points of interest directly located within, there are various type of entertainment, retail, industrial, and transit facility POIs located north of the census tract within the 3-mile buffer. Furthermore, the census tract is in close proximity to the future Southern Grove development area.

- **Population Density** – 3 out of 5 points with 2,247 person per square mile

- **Average Commute Time to Work** – 1 out of 5 points with 6.3% of workers whose commute was 45 minutes or more
- **Median Household Income** – 5 out of 5 points with \$102,646 median household income.
- **Trip Counts** – 5 out of 5 points with 2.7 million origin and destination trips.

Points of Interests – 0 out of 5 points with 0 POIs located inside the census tract.

While these census tracts exhibited the highest AAM demand, it is important to acknowledge that they may not be the most suitable in terms of the composition of land use. **Figure 10** depicts the land use composition of each census tract within the study boundary.

Figure 10 – Generalized Land Use

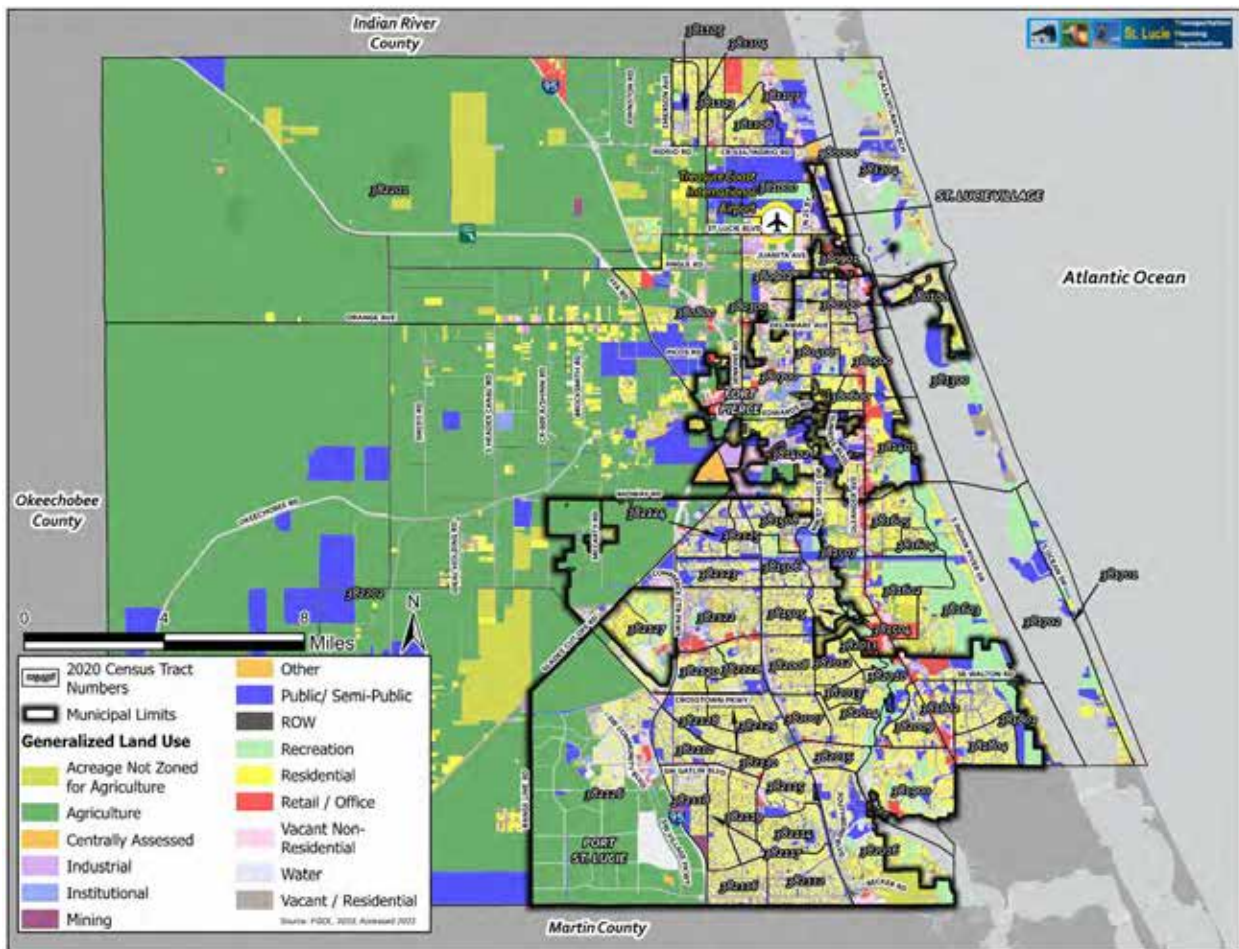

Source: Florida Geographic Data Library (FGDL), 2023

As can be seen from **Figure 10**, the presence of heavy residential land use in the two identified census tracts may amplify the perception of AAM impacts (such as noise, privacy, and safety) to the surrounding communities of the vertiport. Therefore, it is recommended that land use compatibility with the vertiport infrastructure be considered when determining a specific location of the vertiport. To achieve this, a 3-mile threshold (three to ten minutes of driving depending on the area and local speed limit) is established to identify vertiport locations that are more suitable in terms of land use compatibility perspective but also still accessible to the identified high demand census tracts through first- and last-mile connections.

Figure 11 depicts two potential locations for vertiports in the TPO area. The first vertiport is located in St. Lucie West – a commercial/retail area. This location provides convenient access to both census tracts, as it falls within the overlapping area of the two highest demand tracts within a 3-mile radius. The second location is south of census tract # 382130, which is proposed to be developed inside the Southern Grove development. This provides an opportunity for concurrent planning and development of the vertiport infrastructure to ensure that the vertiport is seamlessly woven into the fabric of the overall development.

Figure 11 – Vertiport Locations

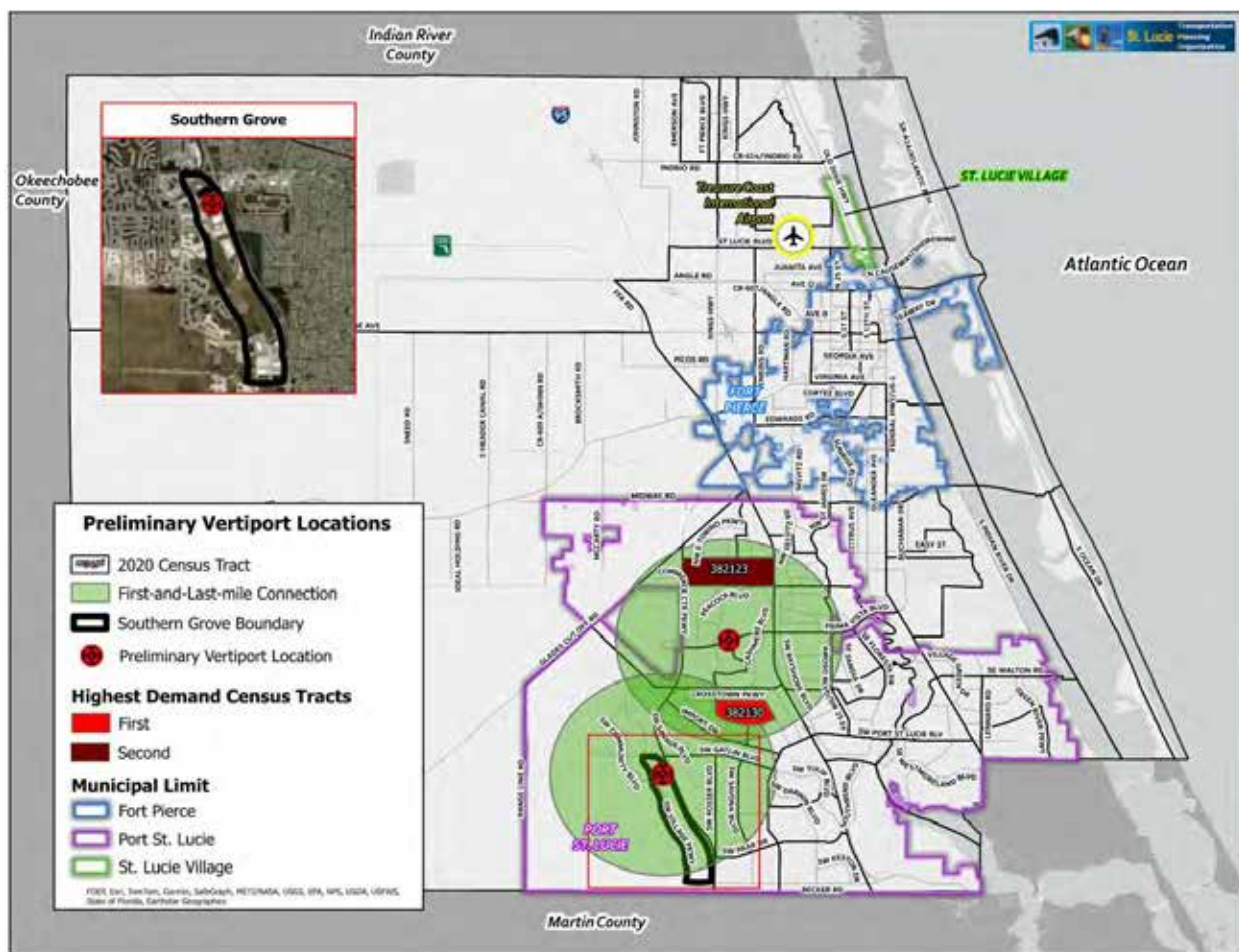

Source: U.S. Census Bureau, 2020

Based on existing transportation indicators, two preliminary vertiport locations have been identified as part of the study. However, discussions with the stakeholders and evaluation of the surrounding land use have indicated that the Port St. Lucie West location may not be feasible for vertiport integration due to foreseen impacts from the AAM corridor. Unlike the Southern Grove development location, which is designated for large-scale manufacturing, logistics, and retail development, the St. Lucie West is in close proximity to existing residential land uses. For these reasons, it is important to consider the vertiport feasibility in relation to the AAM corridors that aircraft will need to traverse to reach the vertiport location.

Although the St. Lucie West vertiport location is still included as a preliminary recommendation, it will further be evaluated in **Chapter 4 – Airspace and Infrastructure Modeling**, which will consider the placement

and impact of AAM corridors to determine the suitability of the identified locations. If deemed unsuitable, the identified locations may be removed/adjusted for the final vertiport recommendation of the study.

Chapter 3. Preliminary Site Review – Treasure Coast International

3.1. Treasure Coast International Airport

Existing aviation assets—airports and heliports—are expected to be the first operating locations for eVTOL aircraft due to the infrastructure in place both on the ground and in the air. As the industry matures, AAM is anticipated to provide air connectivity between airports, mobility hubs, and other locations not traditionally served by aviation in urban, suburban, and rural areas. Given the complexity and long lead times of airport infrastructure projects, it is prudent that airports proactively incorporate AAM considerations into infrastructure, investment, and business planning.

FPR is a public, general aviation (GA) airport sited on 3,660 acres in northeast St. Lucie County, approximately three miles northwest of downtown Fort Pierce and four miles west St. Lucie’s coastline. The Airport is owned and operated by St. Lucie County. As a key economic driver for the region, FPR is well positioned to support the County’s mobility goals through AAM operations.

Existing conditions at the Airport provide a foundation from which a vertiport site review may be based. This section summarizes various facilities and areas at FPR that may impact or be impacted by a vertiport sited at the Airport.

3.1.1. Runways

FPR has three runways. Runway 10R/28L is oriented in an east/west direction and serves as the Airport’s primary runway, measuring 6,492 feet long by 150 feet wide. Notably, a 708-foot western runway extension is noted on FPR’s airport layout plan (ALP), with an ultimate runway length of a minimum of 7,200 feet. Runway 10L/28R is a parallel runway located northwest of 10R/28L. This runway measures 4,000 feet long by 75 feet wide, primarily serves small (i.e., less than or equal to 12,500 pounds) single-engine piston aircraft, and hosts extensive flight training operations. A third runway, designated Runway 14/32 and measuring 4,755 feet long by 100 feet wide, is oriented in a northwest/southeast direction and serves as the Airport’s crosswind runway. Runway 14/32 is located immediately south of Runway 10R/28L and intersects Taxiway A. **Figure 12** illustrates FPR’s runway facilities, including the planned extension to Runway 10R/28L.

Figure 12 – FPR Runways

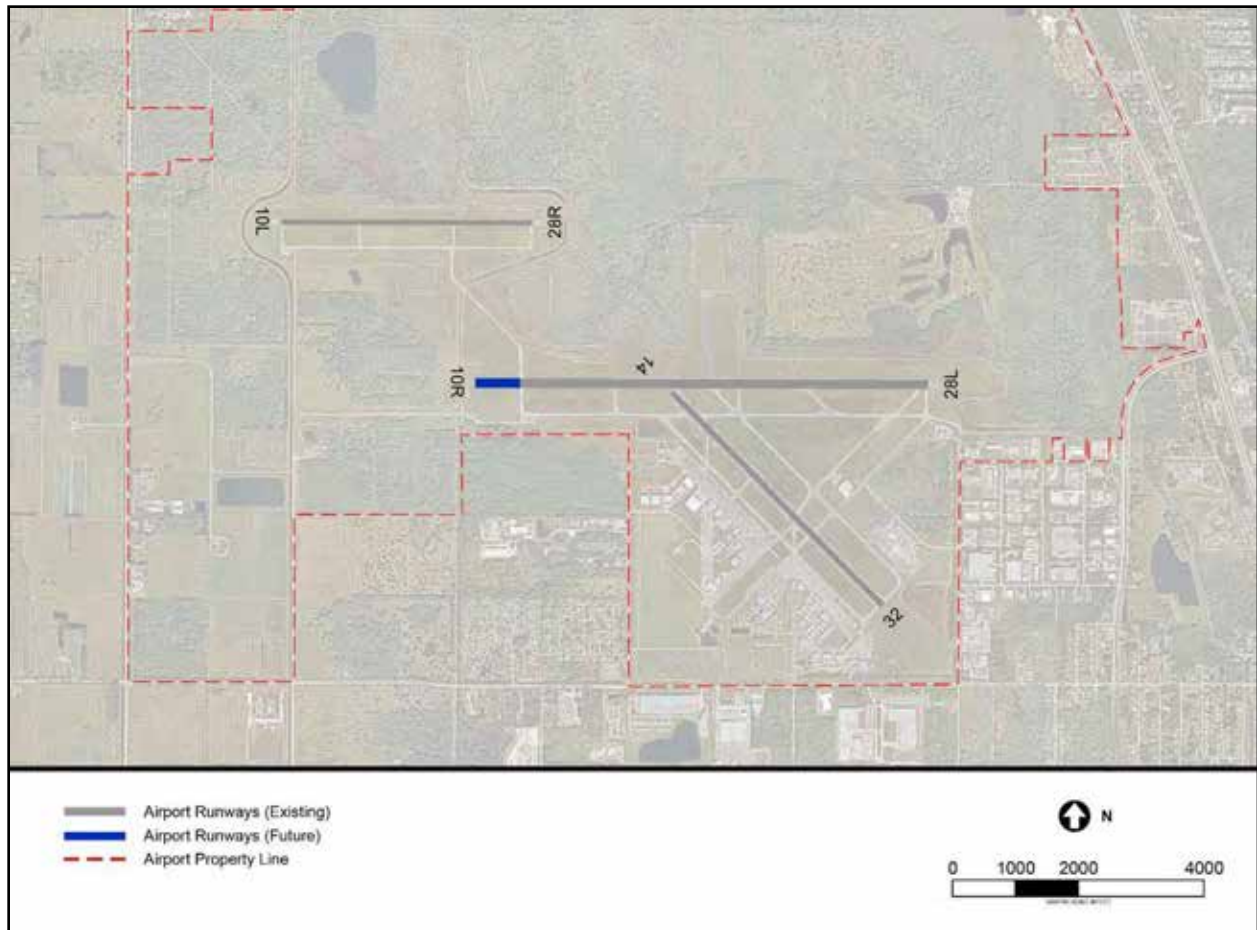

Source: Kimley-Horn, 2024.

Image Source: Nearmap, accessed March 2024.

3.1.2. FPR's Airspace and Operating Procedures

This section provides an inventory of standard aircraft operating procedures and airspace at FPR. This review helps identify potential constraints to future eVTOL operations and preliminary vertiport sites at the Airport. A vertiport located at FPR would represent new aircraft approach and departure paths, in addition to the paths associated with the Airport's existing runways. It is crucial that the site of a vertiport does not adversely impact the safety and efficiency of FPR airspace and fixed-wing aircraft operations.

3.1.2.1. Airspace

FPR is located within Class D airspace, which generally spans from the surface to 2,500 feet above airport elevation at certain airports equipped with an airport traffic control tower (ATCT). At FPR, the Class D airspace has a diameter of three statute miles and extends to 2,523 feet above mean sea level (MSL). Aircraft must establish two-way radio communication with the ATCT prior to entering this airspace.

3.1.2.2. Obstacle Clearance Surfaces

Obstacle Clearance Surfaces (OCS)—approach and departure—help ensure that aircraft have a clear path free from obstacles (e.g., vegetation, structures, poles) when landing at or taking off from a runway. Detailed in FAA Advisory Circular (AC) 150/5300-13B - Airport Design, OCS dimensions vary depending on the

approach capability and visibility minimums of each runway end, and a single runway end may have multiple approach OCSs. The existing approach and departure OCSs at FPR are depicted in **Figure 13**. Future vertiport operations should not adversely impact the approach and departure OCSs.

Figure 13 – Obstacle Clearance Surfaces

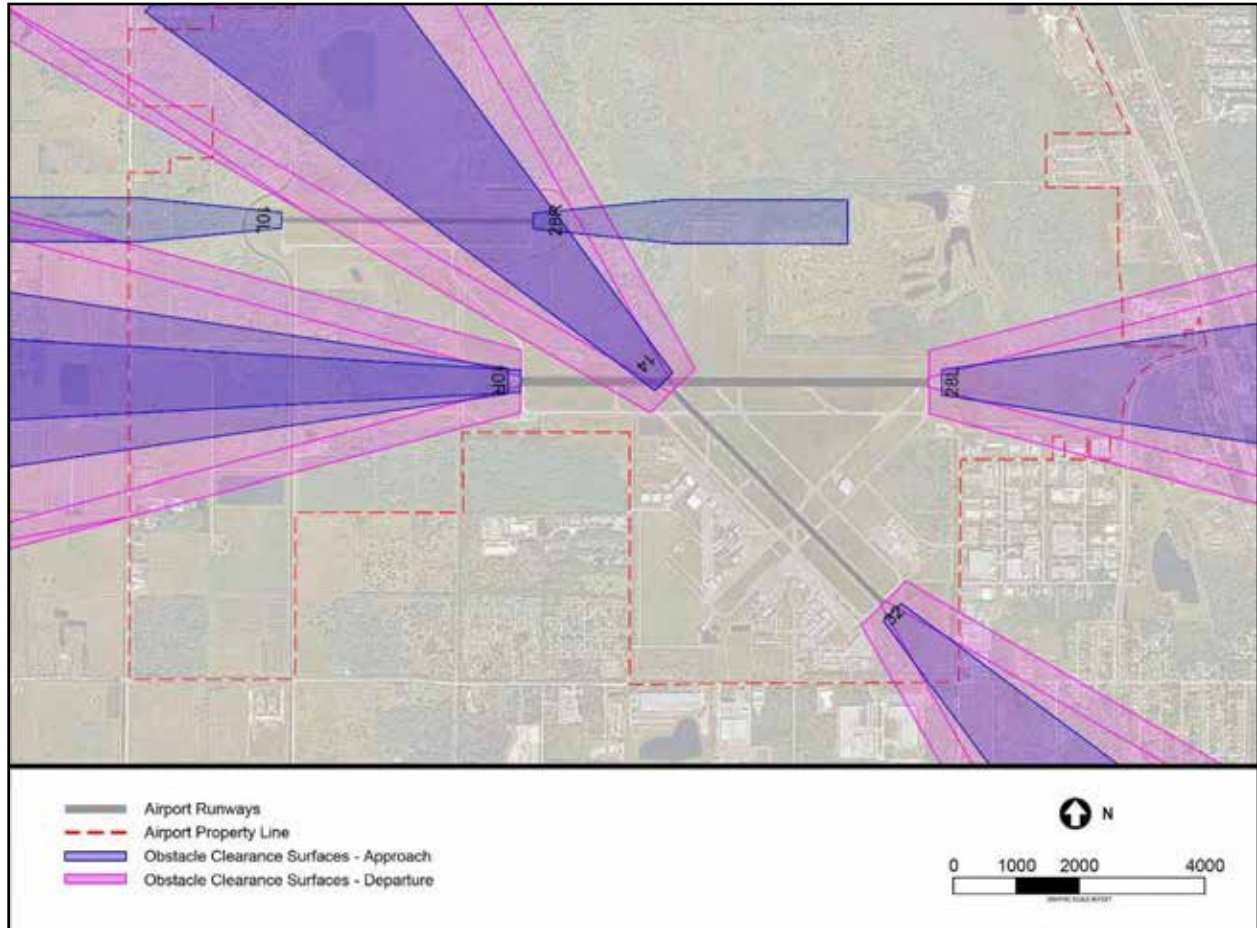

Source: Kimley-Horn, 2024.

Image Source: Nearmap, accessed March 2024.

3.1.2.3. Part 77 Surfaces

Title 14, Code of Federal Regulations, Part 77 - *Safe, Efficient Use and Preservation of the Navigable Airspace* (Part 77) defines airspace surfaces around an airport to identify and mitigate potential obstacles to aircraft operations. Obstacles that are not removable can be mitigated through marking and/or lighting. If not appropriately addressed, obstacles can have a negative impact on runway approach and departure minimums as well as standard operating procedures.

The Part 77 surfaces that are particularly applicable to vertiport siting are:

Primary Surface: The primary surface is centered on a runway centerline and extends 200 feet beyond each runway end. The width of the primary surface depends on a runway's instrument approach capabilities and the aircraft that operate on it. Other than airfield equipment necessary for aircraft ground navigation (e.g., airfield lighting, signage navigational aids), infrastructure should not be located within the primary surface.

Approach Surface: The Part 77 approach surface is separate from and in addition to the approach OCS. An approach surface's dimensions and slope are based on a runway's instrument approach capabilities and the aircraft that operate on it. To the extent practicable, eVTOL operations (i.e., approach and departures) should not disrupt a runway's Part 77 approach surface and ultimately the operations of fixed-wing aircraft.

Transitional Surface: The transitional surface extends outward and upward at a slope of seven to one (i.e., one vertical foot for every seven horizontal feet) from both sides of a runway's primary surface. The transitional surface is often expressed as a building restriction line (BRL) at a given height, which indicates that structures can be no taller than the given height at a specific location. For example, the 35-foot BRL represents the transitional surface's location at 35 feet above ground level (AGL). In this case, structures taller than 35 feet AGL at the location of the 35-foot BRL will penetrate the Part 77 transitional surface and may present a hazard to aircraft operations. While infrastructure is permitted under the transitional surface, it should not obstruct safe air navigation.

FPR's Part 77 primary, approach, and transitional surfaces are depicted in **Figure 14**. The 35-foot BRL is also shown for reference.

Figure 14 – Part 77 Surfaces

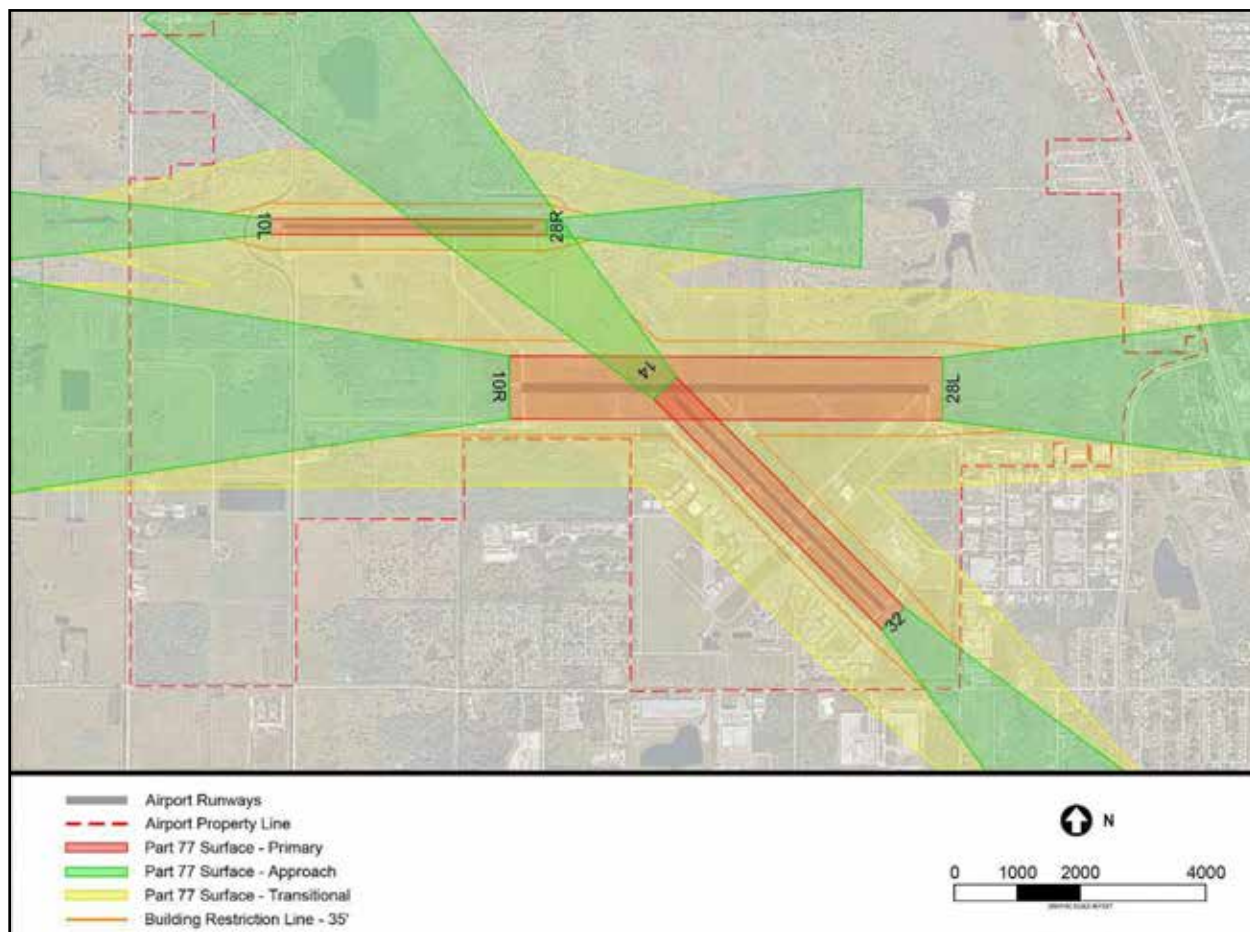

Source: Kimley-Horn, 2024.

Image Source: Nearmap, accessed March 2024.

3.1.2.4. Aircraft Traffic Flow

For arriving aircraft, FPR utilizes a right-hand traffic pattern for Runways 10R, 28R, and 14 and a standard left-hand traffic pattern for Runways 10L, 28L, and 32. Aircraft within the traffic patterns are generally at an elevation of 1,000 feet AGL. Noise sensitive areas exist north and east of the Airport, which are mostly associated with residential communities. Jet aircraft that depart on Runway 10R are asked to maintain the runway heading until they ascend to an altitude of 2,000 feet AGL or until they reach the ocean shoreline prior to making any turns. **Figure 15** illustrates the Airport’s traffic pattern as published in the FPR Voluntary Noise Abatement Procedures brochure. As with airspace surfaces, a vertiport should not disrupt FPR’s runway traffic patterns. Rather, it should be situated to facilitate eVTOL operations that are complimentary to existing airport procedures.

Figure 15 – FPR Traffic Pattern

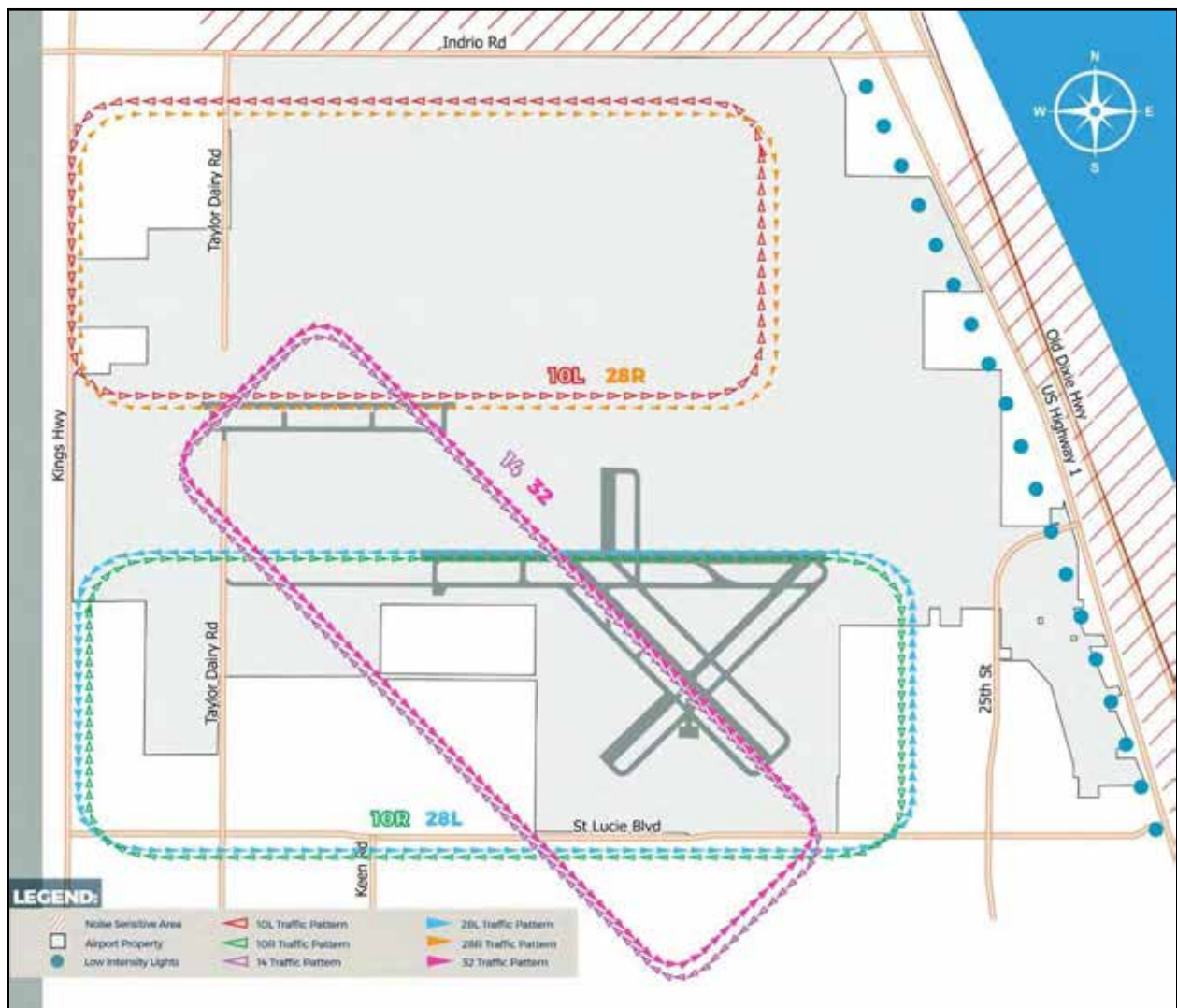

Source: Treasure Coast International Airport, Voluntary Noise Abatement Procedures Brochure.

3.1.3. Landside Access

Primary vehicular access to FPR is provided on the south side of the Airport by Curtis King Boulevard via St. Lucie Boulevard/County Road 608 (East). This area of the Airport hosts the fixed-base operator (FBO) terminal, U.S. Customs facility, the Airport's restaurant, two flight schools, aircraft hangars, and various Airport tenants. Several other roadways provide access to facilities throughout the airfield: The aircraft hangars east of Runway 14/32 are accessed by Jet Center Terrace via Industrial 33rd Street, and facilities west of Runway 14/32 can be accessed via Hammond Road, Crosswind Drive, Tailwind Drive, and Airman's Way.

3.2. Vertiport Standards

3.2.1. Engineering Brief No. 105

Planning and design guidance for vertiports are provided by the FAA Engineering Brief No. 105 (EB 105) (September 21, 2022). EB 105 serves as the FAA's temporary guidance for vertiport design to support initial infrastructure development for eVTOL operations. The FAA has limited verified eVTOL aircraft performance data and is therefore taking a conservative approach with EB 105's recommendations. Eventually, vertiport guidance is expected to transition into aircraft performance-based design standards. In the meantime, EB 105 is a dynamic document that serves as the FAA's initial interim guidance and will be updated as more performance data is obtained to address new aircraft and technology.

3.2.1.1. EB 105 Reference Aircraft

Due to the rapid development and diverse designs of emerging eVTOL aircraft, the FAA utilizes a "Reference Aircraft" in EB 105 to establish baseline vertiport design criteria. This reference aircraft was developed in coordination with various original equipment manufacturers (OEMs) and incorporates common features observed among nine current eVTOL prototypes, such as multiple engines and emergency hover capabilities. The FAA acknowledges this is a temporary solution and plans to refine vertiport design guidance as they gather more data from evolving VTOL technologies. The foundation for this study is based on guidance and criteria from the EB 105 reference aircraft.

3.2.2. Vertiport Design and Geometry

Vertiport design and geometry standards are developed to promote safe and efficient eVTOL operations. Elements of a vertiport include the Touchdown and Liftoff (TLOF) Area, Final Approach and Takeoff (FATO) Area, and Safety Area. **Figure 16** on the following page illustrates the sizes of these elements, which are based on the dimensions of a specific design aircraft.

In this figure, "D" represents the controlling dimension. EB 105 defines D as "The diameter of the smallest circle enclosing the VTOL aircraft projection on a horizontal plane, while the aircraft is in the takeoff or landing configuration, with rotors/propellers turning, if applicable." The value of D for the reference aircraft in EB 105 eVTOL aircraft is 50 feet. According to the FAA, as more validated performance data for individual eVTOL aircraft becomes available, these criteria may be adjusted accordingly. Descriptions of the vertiport TLOF, FATO, and safety area are provided below. For more detailed design information on each element, refer to EB 105 and, if applicable, AC 150/5390-2D - Heliport Design.

3.2.2.1. TLOF

At the center of the vertiport is the TLOF, which is load bearing and generally paved. This area is where an eVTOL aircraft performs a touchdown and liftoff maneuver. The TLOF should be clear of any ground objects (e.g., lighting, charging stations, air vents). Airspace surfaces should be clear of any obstacles when planning for the siting of the TLOF. This will ensure a safe approach and departure of an aircraft and prevent any penetrations to approach/departure and transitional surfaces.

As mentioned previously, the TLOF should be load bearing to support the weight of the design eVTOL aircraft and any operating ground vehicles within the area. EB 105 states that the TLOF should support dynamic loads based on 150 percent of the maximum takeoff weight (MTOW) of the design eVTOL aircraft. Using the EB 105 reference eVTOL aircraft with an MTOW of 12,500 pounds, the TLOF should support dynamic loads of up to 18,750 pounds. Rotor/propeller downwash is also accounted for in this load requirement.

Figure 16 – Vertiport Elements

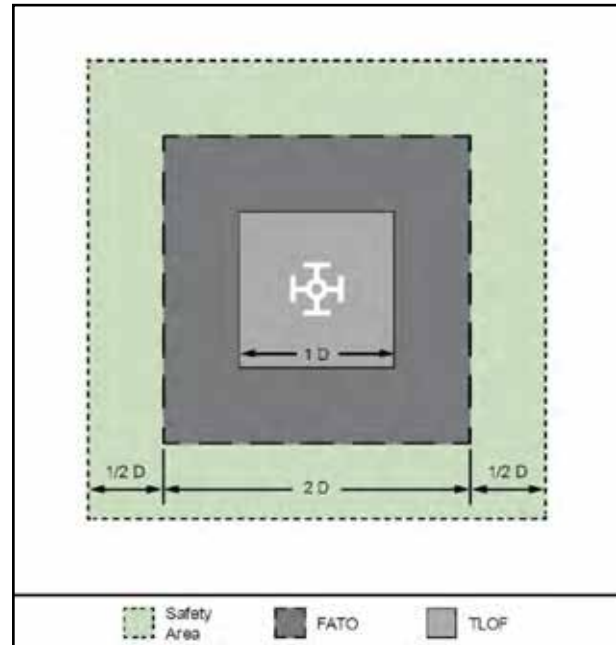

Source: FAA, Engineering Brief 105 - Vertiport Design, 2022

3.2.2.2. FATO

The FATO surrounds the TLOF and is a defined area where an eVTOL aircraft completes the final phase of its approach and first phase of its departure (i.e., initial/final hover before initiating takeoff/landing). Like the TLOF, the FATO is generally a paved surface, should be clear of obstacles and ground objects, and should support dynamic loads based on 150 percent of the MTOW of the design eVTOL aircraft.

3.2.2.3. Vertiport Safety Area

The Safety Area is a designated space surrounding the FATO to minimize the risk of unintentional diversion for eVTOL aircraft. To ensure safety, the Safety Area should not contain any fixed objects such as parapet walls, lighting, elevator penthouses, canopies, or exhaust vents. However, certain navigation aids (NAVAIDs) that are classified as "fixed-by-function" by the FAA can be placed within the Safety Area as long as they are mounted on frangible supports, similar to how they are implemented on runways.

3.2.3. Vertiport Airspace

The purpose of vertiport airspace surfaces is to promote safe and unobstructed operations of eVTOL aircraft near a vertiport. These surfaces are summarized below. It is important to note that the FAA's published guidance on vertiport airspace pertains to visual flight rules (VFR), which is the expected operating mode for initial eVTOL aircraft. Future guidance will include information on airspace considerations for instrument flight rules (IFR) operations.

3.2.3.1. Part 77 Surfaces

Like Part 77 surfaces for runways, the airspace surfaces associated with vertiports are defined in Part 77 for heliports. These surfaces include the primary, approach, and transitional surfaces, which are summarized below and shown in **Figure 17**.

Primary Surface: The vertiport's primary surface is a flat, level area that aligns with the shape and size of the FATO. The elevation of the primary surface matches the established elevation of the vertiport.

Approach Surface: The approach surfaces begin at each end of the vertiport primary surface. They have the same width as the primary surface and extend outward and upward for a horizontal distance of 4,000 feet at a slope of 8:1. The outer widths of the approach surfaces are 500 feet. Per EB 105, a vertiport's Part 77 approach surfaces also serve as the VFR approach/departure paths. These paths must be clear of all obstacles to ensure a safe operating environment for eVTOL aircraft.

Transitional Surface: Transitional surfaces extend outward and upward from the lateral boundaries of the primary surface and the approach surfaces. These surfaces extend for a horizontal distance of 250 feet at a slope of 2:1 from the center of the primary and approach surfaces.

Figure 17 – Vertiport Part 77 Surfaces

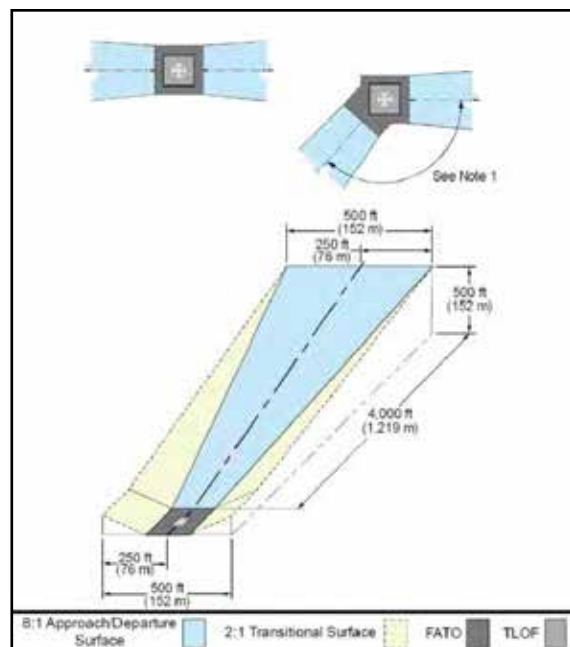

Source: FAA, *Engineering Brief 105 - Vertiport Design*, 2022

3.2.3.2. Approach / Departure Paths

Vertiport approach/departure paths are the designated flight paths for eVTOL aircraft takeoff and landing at a vertiport. Similar to airport runways, these paths should be aligned with the prevailing wind direction. If a vertiport is located at an airport, it is important that these paths should not interfere with the existing approach and departure surfaces of the runways.

Ideally, vertiports should be designed to accommodate approaches and departures from two different directions, allowing for bidirectional use. It is preferable for these paths to have reciprocal magnetic headings, such as 180 degrees and 360 degrees, and should be free from any obstacles. However, in certain situations where there are obstacles, sensitive land uses, or other constraints, it may be necessary to curve the approach and departure paths to avoid any conflicts.

3.2.4. Vertiport Support Facilities

When conducting a spatial analysis for vertiport infrastructure, it is essential to consider not only the previously mentioned elements but also the necessary support facilities and components needed for operations, including but not limited to:

- Vertiport lighting (required for nighttime operations)
- NAVAIDs (e.g., wind cones, visual glideslope indicator [VGSII])
- Aircraft stands and charging stations
- Ground service equipment
- Maintenance facilities
- Passenger facilities
- Emergency services

- Security features

3.3. Site Review

3.3.1. Vertiport Orientation

Runways are meant to be oriented such that aircraft can take off and land in the same direction as the prevailing wind (into the wind). Like a runway, a vertiport's approach/departure surfaces should be aligned in the direction of the prevailing wind to the extent practicable. Vertiport approach/departure surfaces should also complement existing airport infrastructure and limit impacts to runway operations. Therefore, it is recommended the vertiport approach/departure surfaces at FPR be aligned in an east-west orientation parallel to Runways 10R/28L and 10L/28R. Notably, Runway 14/32 provides an alternative landing direction during crosswind conditions, primarily for smaller aircraft. Given that eVTOL aircraft will likely be sensitive to the same crosswind components as small aircraft, supplementary vertiport approach/departure alignments in a 14/32 orientation should also be considered. Operational considerations associated with parallel and convergent runway/vertiport operations are discussed in the sections below.

3.3.2. Landside Access

As previously noted, efficient landside access is critical to maximizing the benefit of AAM to an airport and its community. Therefore, potential vertiport development sites should be located in a way that facilitates convenient access to existing airport access roads, other airport facilities, and local and regional roadways. As such, the following analyses primarily focus on available land adjacent to existing development at FPR—specifically, land south of Runway 10L/28R. Based on current lack of accessibility, vast undeveloped land, and distance from existing access roads, the northern half of Airport property is not recommended to be considered for initial vertiport infrastructure. However, industry growth and local demand for AAM should be monitored as the suitability of the northern half of Airport property for AAM-related development may be revisited in the future.

3.3.3. Vertiport / Runway Separation

The distances between parallel runway centerlines and vertiport approach/departure surfaces play a crucial role in ensuring the safety and efficiency of fixed-wing aircraft, helicopters, and eVTOL aircraft that operate in close proximity to one another. Standard distances between facilities take into consideration various factors such as the type of aircraft, approach speed, and characteristics of wake turbulence. It is critical that the location of a vertiport is carefully chosen to avoid compromising airport safety and to minimize any negative impacts on existing airport operations, capacity, and delays. The minimum separation distances between FPR's runways and potential future vertiport infrastructure for VFR, IFR, and wake turbulence considerations are illustrated in [Figure 18](#).

3.3.3.1. VFR Operations

EB 105 establishes standards and guidelines for separation distances between the centerlines of approach/departure surfaces for both runways and vertiport during simultaneous, same-direction operations under VFR. These guidelines, summarized in [Table 3](#), assume that the EB 105 reference eVTOL aircraft has an MTOW of 12,500 pounds or less.

Table 3 – Minimum Distance between Runway Centerline and Vertiport FATO for VFR Operations

Airplane Size (MTOW) *	Distance between Runway Centerline and Vertiport FATO Center †
Small (≤ 12,500 lbs.)	300'
Large (12,500 lbs. to 300,000 lbs.)	500'
Heavy (> 300,000 lbs.)	700'

Notes:

VFR = Visual Flight Rules

MTOW = Maximum Takeoff Weight

*Airplane Size refers to the MTOW of fixed-wing aircraft operating on a parallel runway to a vertiport approach/departure surface.

†Assumes eVTOL aircraft with an MTOW of 12,500 pounds or less

Source: FAA Engineering Brief 105 - Vertiport Design, 2022.

FPR's three runways each accommodate varying aircraft type, leading to different standard separation distances from runway centerlines to a vertiport's FATO center:

Runway 10L/28R: As a visual runway constructed for small single-engine piston aircraft, Runway 10L/28R primarily hosts aircraft with MTOWs less than or equal to 12,500 pounds. Therefore, a vertiport should be sited no closer than 300 feet from the centerline of Runway 10L/28R.

Runway 10R/28L: Runway 10R/28L serves as the primary runway at FPR and hosts a variety of aircraft operations. According to the FAA's Traffic Flow Management System Counts (TFMSC) database, several aircraft with MTOWs between 12,500 and 300,000 pounds consistently operate on Runway 10R/28L. As such, a vertiport should be sited at least 500 feet from the centerline of Runway 10L/28R.

Runway 14/32: Runway 14/32 serves as the Airport's crosswind runway and, like Runway 10R/28L, accommodates a variety of aircraft type. To ensure compatibility with fixed-wing aircraft operations on the runway, a vertiport should be sited at least than 500 feet from the centerline of Runway 14/32.

3.3.3.2. IFR Operations

The guidance in EB 105 for vertiport/runway separation is limited to VFR operations. Given there are published instrument approach procedures on Runways 10R/28L and 14/32 at FPR, an evaluation of available guidance on instrument flight rules (IFR) and its criteria is necessary. At the time of writing, the FAA is developing vertiport-specific IFR operations criteria. In the meantime, FAA Advisory Circular 150/5300-13B and FAA Order JO 7110.65AA – Air Traffic Control (JO 711.65AA) can be referenced for criteria related to simultaneous, same-direction IFR aircraft operations at airports. These criteria are based on runway separation, airport elevation, and aircraft departure course.⁴

Simultaneous IFR Approaches: For simultaneous IFR approaches at airports below 2,000 feet MSL, like FPR (23.4 feet MSL), a minimum separation distance of 3,200 feet between parallel runway centerlines is required for straight-in instrument approaches. Alternatively, a separation of 2,500 feet is allowed if there is an offset approach to one runway end.

Simultaneous IFR Departures: Simultaneous IFR departures are permitted with a minimum runway separation distance of 2,500 feet as long as the aircraft departure courses diverge by at least 10 degrees.

⁴ FAA Advisory Circular 150/5300-13B - Airport Design, March 2022.

Alternatively, a separation of less than 2,500 feet is permitted if the departure courses diverge by at least 15 degrees.

Simultaneous IFR Mixed Operations: In the case of simultaneous IFR mixed operations, where an aircraft is departing on one runway while another aircraft is on final approach to a parallel runway, the parallel runways must be separated by at least 2,500 feet.⁵

As previously noted, a vertiport's approach/departure surfaces should be aligned in the direction of the prevailing winds to the extent practicable and should not interfere with existing airport operations. As such, it is recommended the primary vertiport approach/departure surfaces at FPR be aligned in an east-west orientation and parallel to Runways 10R/28L and 10L/28R, with supplementary approach/departure surfaces aligned in an 14/32 orientation to support operations in periods of crosswinds.

Although guidance is only available for VFR eVTOL operations, it is prudent to plan conservatively to ensure safe and efficient airport operations in the future. To protect for potential simultaneous parallel IFR operations between fixed-wing aircraft and eVTOL, a vertiport at FPR should be located at least 2,500 feet from the centerline of Runway 10R/28L (this recommendation does not apply to Runway 10L/28R given that it does not have published instrument procedures). As described above, a separation of less than 2,500 feet from the runway centerline may be acceptable if the vertiport FATO is offset from the runway ends.

3.3.3.3. Wake Turbulence

Both AC 150/5300-13B and JO 7110.65AA reference FAA Order JO 7110.126B – Consolidated Wake Turbulence (JO 7110.126B) as a resource for managing wake turbulence separation during parallel operations involving aircraft and helicopters. JO 7110.126B provides guidelines and recommendations for minimizing the impact of wake turbulence caused by aircraft. The order categorizes aircraft based on their MTOW and their ability to withstand encounters with wake turbulence. This categorization, ranging from Category A (largest aircraft) to Category I (smallest aircraft), helps determine the necessary separation distances between aircraft during takeoff and landing.

The EB 105 reference eVTOL aircraft has an MTOW of 12,500 pounds and is categorized by JO 7110.126B as “Category I – Lower Small,” defined as any aircraft with an MTOW of 15,400 pounds or less (not to be confused with the FAA’s general definition of “small” aircraft with an MTOW of 12,500 pounds or less). According to 2023 FPR operations data from the FAA’s TFMSC database, there were 2,914 operations by aircraft categorized as “Category H – Upper Small,” 331 operations of “Category G – Lower Large,” 136 operations of “Category F – Upper Large,” and nine operations of “Category E – B757.” There were no operations at FPR in 2023 by aircraft categorized as D, C, B, or A.

For this discussion, it is assumed a vertiport at FPR would have primary approach/departure surfaces that are aligned in an east-west orientation and parallel to Runway 10R/28L, as recommended above. For parallel runways (i.e., Runway 10R/28L and a future vertiport), JO 7110.126B states that ATC should separate Category I aircraft behind Category E aircraft by two minutes when departing parallel runways that are separated by less than 700 feet *or* if parallel runways separated by at least 700 feet have intersecting flight paths. In the case of nonintersecting converging runways (i.e., Runway 14/32 and a future vertiport), ATC should separate Category I aircraft behind Category E aircraft by two minutes if flight paths with cross.

⁵ When parallel runways are staggered, runway separation distance may be reduced based on the distance of threshold stagger.

Although there were only nine operations by aircraft with a Category E designation at FPR in 2023, a conservative planning approach to vertiport infrastructure should account for long-term changes in an airport's fleet mix. Therefore, it is recommended that a vertiport is sited at a minimum of 700 feet from all existing runway centerlines at FPR. Given that Runway 10L/28R only accommodates small, single-engine piston aircraft, these wake turbulence separation distances for vertiport siting do not apply to the visual runway.

3.3.3.4. Summary of Vertiport/Runway Separation

As shown in **Figure 18**, the separation distances of 500 feet associated with VFR operations on both Runways 10R/28L and Runway 14/32 are superseded by the separation distances of 700 feet associated with wake turbulence considerations. Furthermore, the recommended separation distance between Runway 10R/28L and a future vertiport is 2,500 feet to protect for simultaneous IFR mixed operations. Notably, this distance of 2,500 feet may be reduced with a staggered runway threshold and vertiport FATO, which is likely to be the case. The Airport's fleet mix and runway operations should be monitored for significant changes that may impact vertiport wake turbulence considerations.

Figure 18 – Vertiport / Runway Separation Distances

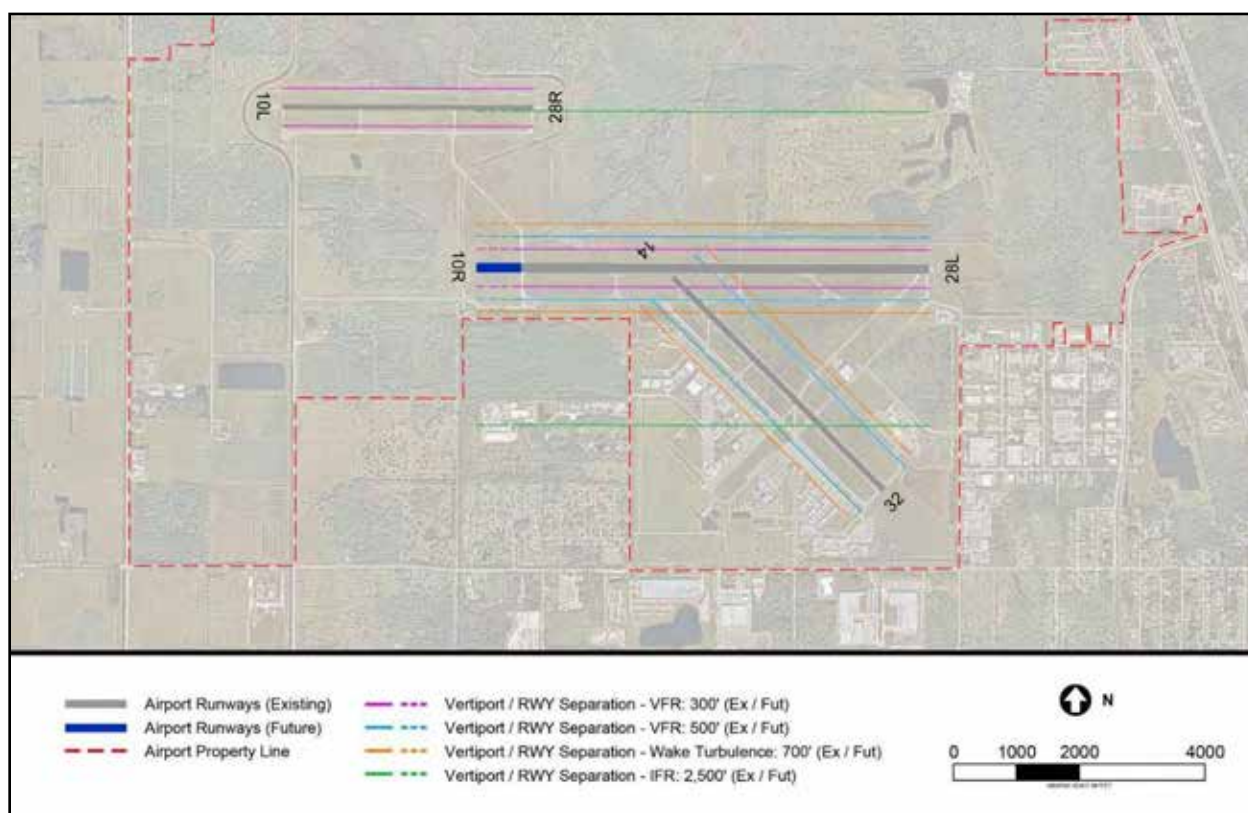

Source: Kimley-Horn, 2024.

Image Source: Nearmap, accessed March 2024.

3.4. Preliminary Sites

Thus far, this chapter has summarized the airspace at FPR (OCS and Part 77 surfaces), the general airspace surfaces associated with vertiports (approach/departure and transitional surfaces), vertiport and runway separation requirements, landside connectivity, and various other vertiport siting considerations.

Figure 19 layers various vertiport siting considerations into one exhibit to help further define preliminary sites for a vertiport at FPR. As shown, seven preliminary vertiport sites have been identified based on the analyses in the previous section. These sites are adequate in size to accommodate an eVTOL takeoff/landing area and supporting infrastructure, including aircraft parking stands, electric aircraft charging stations, taxiways, pedestrian areas, terminal facilities, ground vehicle parking, and landside access roadways.

Figure 19 – Preliminary Vertiport Sites

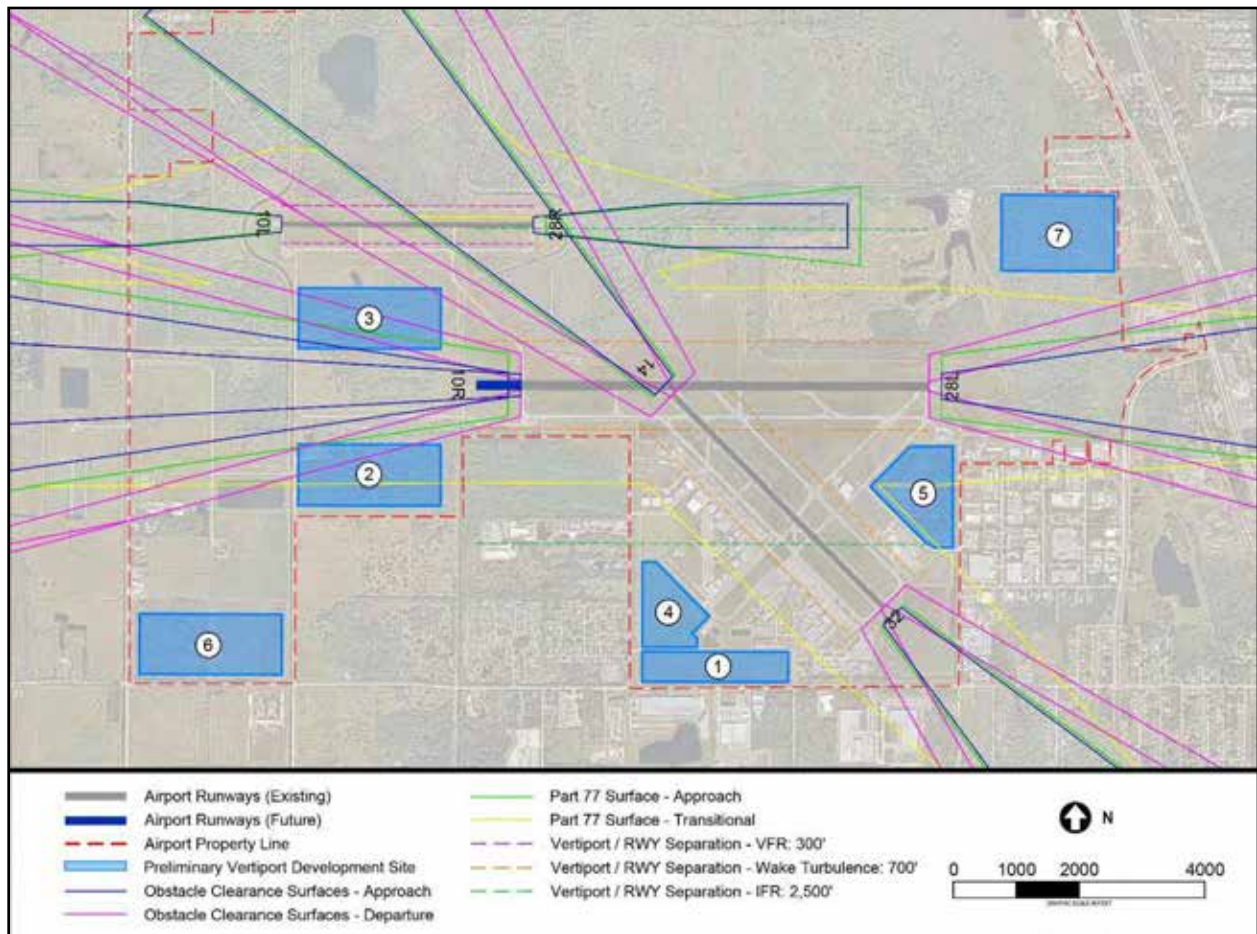

Source: Kimley-Horn, 2024.
 Image Source: Nearmap, accessed March 2024.

3.4.1. Initial Review of Preliminary Sites

Airport management was consulted regarding the preliminary sites identified in **Figure 19**, and noted that Sites 4 and 5 are earmarked for near-term aeronautical development. With requests for proposals (RFPs) being released for both parcels, these sites are not available for vertiport infrastructure.

Site 7 is aligned with the extended centerline of Runway 10L/28R. A vertiport sited in this location may disrupt aircraft operations on the runway, especially with the high level of training operations that occur on this runway. Additionally, the site is located adjacent to a mobile home residential community and would facilitate eVTOL operations near several other residential neighborhoods.

Site 3, while complying with vertiport/runway separation distances and not falling along an extended runway centerline, is located in a congested portion of the airfield in terms of airspace. Additionally, there is no existing landside access to this site, which would substantially increase the total cost of improvements.

Based on this initial review, Sites 3, 4, 5, and 7 will not be considered for vertiport development at the Airport. The following sections perform a deeper dive into the remaining sites: Sites 1, 2, and 6.

3.4.2. Vertiport Airspace Obstacle Analysis

To promote safe eVTOL operations during flight, it is necessary to protect the vertiport Part 77 surfaces and the corresponding approach/departure paths from any obstacles. Airport obstacles were sourced from available data in the FAA's OE/AAA database to determine potential objects that may affect the imaginary surfaces of vertiports located within the three preliminary sites.

Figure 20 below shows the obstacle data and adds vertiport imaginary surfaces to each preliminary site. Although the exact location of a vertiport on each site can vary, this visual provides an initial review of potential obstacles to these surfaces. Obstacles near the preliminary vertiport sites include trees, utility poles, and buildings. Trees can be trimmed or removed, but the ultimate location of a vertiport should ensure objects that cannot be easily relocated or moved, such as utility poles and buildings, do not penetrate the imaginary surfaces.

A review of the obstacle data shows that while there are some trees, utility poles, and buildings located within the limits of the vertiport imaginary surfaces, these objects would not penetrate the surfaces and therefore would not be deemed hazards to air navigation. As such, there are no significant obstacle constraints that prevent a vertiport from being sited in either of the three preliminary locations.

It is important to note that data within the FAA's OE/AAA database represent existing obstacles to the imaginary surfaces of the Airport's runways (i.e., OCS, Part 77 surfaces). Prior to selecting a vertiport site at FPR, a site-specific obstacle analysis should be conducted to identify potential hazards to eVTOL operations and, if necessary, an obstacle mitigation plan should be developed.

Figure 20 – Airport Obstacles

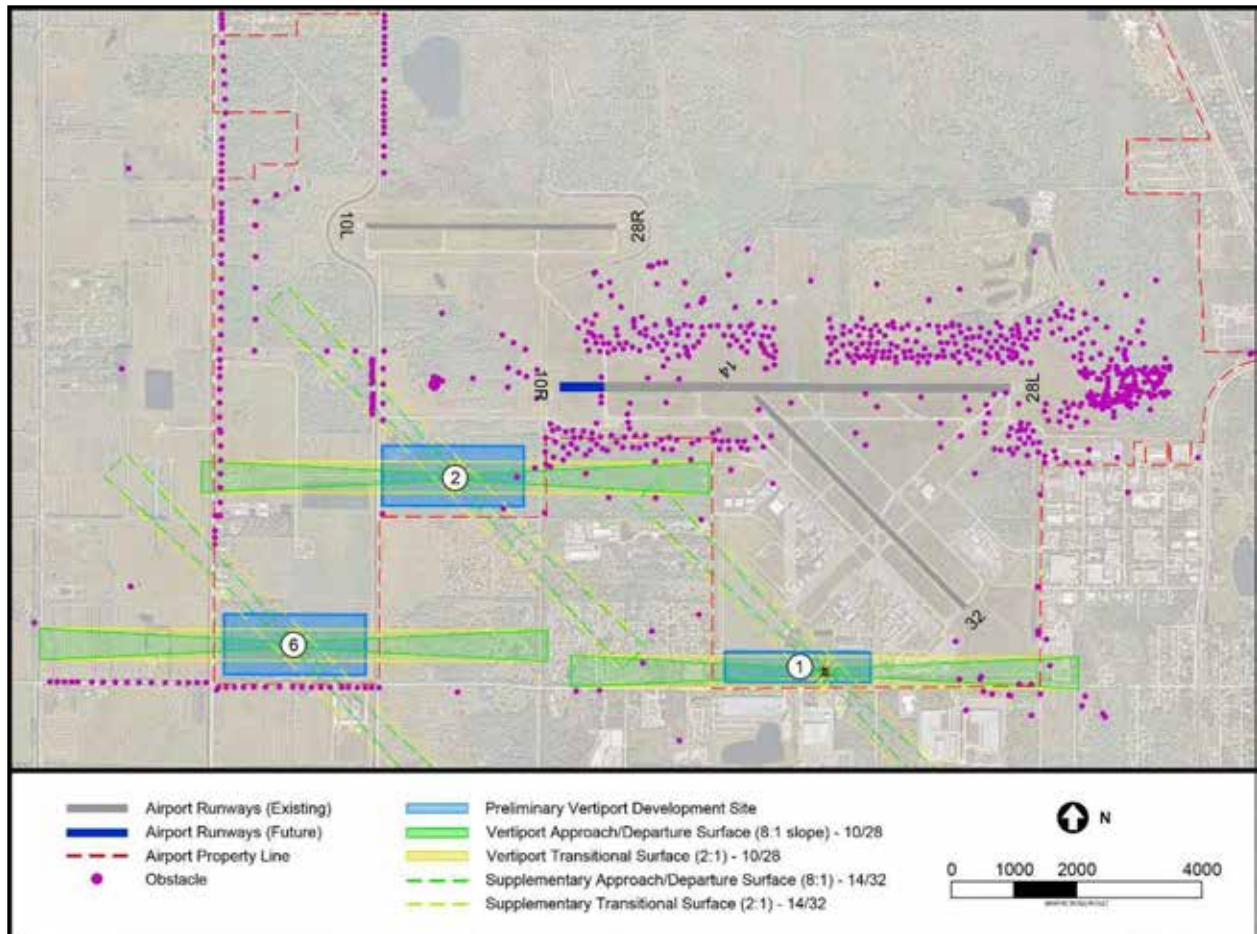

Source: Kimley-Horn, 2024.

Obstacle Data Source: FAA Obstruction Evaluation / Airport Airspace Analysis (OE/AAA) database (accessed March 2023).

Image Source: Nearmap, accessed March 2024.

3.4.3. Integration into Airport Operations

A vertiport at FPR must facilitate eVTOL operations that effectively integrate into the Airport's existing procedures to promote the safe and efficient movement of aircraft in the airspace and on the ground. Referencing the Airport's traffic pattern in [Figure 15](#), Site 1 is located inside the traffic patterns of Runways 10R/28L and 14/32, Site 2 is located inside the Runway 10R/28L traffic pattern and directly under the traffic pattern of Runway 14/32, and Site 6 is located within the southwest corner of the Runway 10R/28L pattern. Recognizing that a vertiport's approach/departure surfaces at FPR are ideally aligned in an east-west orientation (parallel to Runway 10R/28L) with supplemental approach/departure surfaces aligned in an 14/32 alignment, an eVTOL aircraft approaching/departing a vertiport located in Sites 1, 2, or 6 may conflict with fixed-wing aircraft in the Airport's traffic patterns. Coordination to ensure smooth aircraft traffic flow may increase ATC workload, especially during peak periods of activity.

Alternatively, neither of the three preliminary sites conflict with the traffic pattern of Runway 10L/28R. Unlike the patterns of Runways 10R/28L and 14/32, which are primarily used to facilitate aircraft departures and arrivals, the Runway 10L/28R traffic pattern is frequently utilized for training activity and may have multiple aircraft in the traffic pattern at one time while performing touch-and-go maneuvers.

Regarding ground operations, both Sites 1 and 2 are adjacent to existing taxiways/taxilanes. In the event that an eVTOL aircraft needs to access other facilities on the airfield, such as maintenance and repair, a taxilane connection may be made to support ground taxiing or tug operations. Site 6 is located west and south of existing airfield facilities on a portion of Airport property that extends south, like a peninsula. Additionally, the Airport does not own properties between the main landside area and Site 6, and Airport-owned parcels north of Site 6 are currently non-aeronautical uses, eliminating the possibility to connect a vertiport on Site 6 with the airfield.

3.4.4. Landside Considerations

3.4.4.1. Access Roadways and Landside Facilities

Access roadways are critical to connecting an airport's facilities and the communities they serve. With sustained, streamlined mobility being among AAM's key objectives, efficient landside access will play a critical role in facilitating first- and last-mile transportation for eVTOL users.

Site 1 is located near the main access point to the Airport and may be accessed by Curtis King Boulevard via St. Lucie Boulevard/County Road 608 (East). This location near existing Airport access points provides for efficient vehicular connectivity between a vertiport and the St. Lucie County roadway network. Site 1 is also conveniently located near FPR's main landside campus, including the FBO, U.S. Customs facility, restaurant, and flight schools.

Sites 2 and 6 are located further from the Airport's existing landside areas than Site 1. Site 2 can be accessed via Taylor Dairy Road, an unpaved roadway. It is likely this road will require improvements should a vertiport be located in Site 2. Site 6, while located further from the Airport's landside areas, is accessible via St. Lucie Boulevard/County Road 608 (East). As discussed, however, Site 6 is separated from the rest of Airport property with future aeronautical connectivity being unlikely due to the number of non-aeronautical uses that surround the site.

The Airport's access roadways are shown on the following page in **Figure 21**.

Figure 21 – Access Roadways



Source: Kimley-Horn, 2024.

Image Source: Nearmap, accessed March 2024.

3.4.4.2. Emergency Response

Landside access also facilitates efficient emergency response in the event of an incident at or around a vertiport. As shown above in **Figure 21**, FPR has an on-site Aircraft Rescue and Fire Fighting (ARFF) facility located immediately south of Runway end 28L. ARFF personnel utilize ground vehicles (e.g., ARFF trucks) to access emergencies throughout the Airport. Preliminary vertiport Sites 1 and 2 can be accessed by ARFF personnel via the airfield as long as vehicle service roads provide access between existing airfield facilities and the vertiport development area. Given the remote nature of Site 6, ARFF personnel would be required to exit the airfield, travel south on Industrial 33rd Street, and then west on St. Lucie Boulevard/County Road 608 (East) to access the vertiport—an approximately 3-mile trip around the perimeter of Airport property.

3.4.5. Preliminary Site Determination

Based on the analyses within this chapter, Sites 1, 2, and 3 are capable of hosting vertiport operations in the future—the sites do not conflict with runway imaginary surfaces and are not constrained by airspace obstacles. For all sites, ATC will be required to coordinate eVTOL operations in/out of the vertiport to avoid interference with aircraft in runway traffic patterns. As noted above, however, Site 1 provides the most efficient landside connectivity for both eVTOL users and ARFF personnel of the three sites. Additionally,

vertiport infrastructure on the site may benefit from adjacent utilities associated with existing development. Therefore, this study favors Site 1 as the leading candidate for future vertiport development at FPR.

The St. Lucie TPO recognizes the Airport's autonomy in infrastructure planning at FPR. The analyses and recommendations of this study are meant to provide initial due diligence to support AAM adoption and integration at FPR and throughout St. Lucie County. It is recommended the Airport conduct additional site investigation and planning to confirm, refine, and/or revise the recommendations of this study.

3.5. Assumptions and Limitations

AAM is a developing industry in its early stages. At the time of writing, validated data for eVTOL aircraft are not readily available, and subsequent guidance and regulations for vertiport development and AAM operations are preliminary in nature. In response to this rapidly evolving industry, the FAA has advised interested parties to refer to existing guidance, such as EB 105, AC 150/5300-13B, and Part 77, for initial AAM planning.

While a preliminary site investigation such as this one is the first step in reviewing feasibility of an area for vertiport development, future studies should be conducted to gather input from stakeholders and subject-matter experts, and a thorough analysis of the site should be performed using the latest FAA standards, airport survey data, and industry trends. Future studies should also include reviews of ATC line-of-sight from the ATCT to the vertiport, the capacity of the local power grid to support electric aircraft charging stations, and the land use and zoning surrounding a vertiport. Furthermore, additional site investigation and engineering design—including environmental, grading, stormwater, and utilities—should be conducted prior to finalizing site plans for a future vertiport at FPR.

Based on this information, limited regulatory guidance, and a lack of published aircraft operational and performance data, the findings and recommendations of this study should not be used as the sole basis for the Airport's decision making.

Chapter 4. Airspace and Infrastructure Modeling

4.1. Airports in St. Lucie

The first step of any airspace modeling task is to understand the location of local airports and heliports that influence the structure of airspace surrounding the study area. Airports and heliports (both public and private) surrounding the study area are shown in **Figure 22**.

Figure 22 – Local Airports and Heliports Facilities

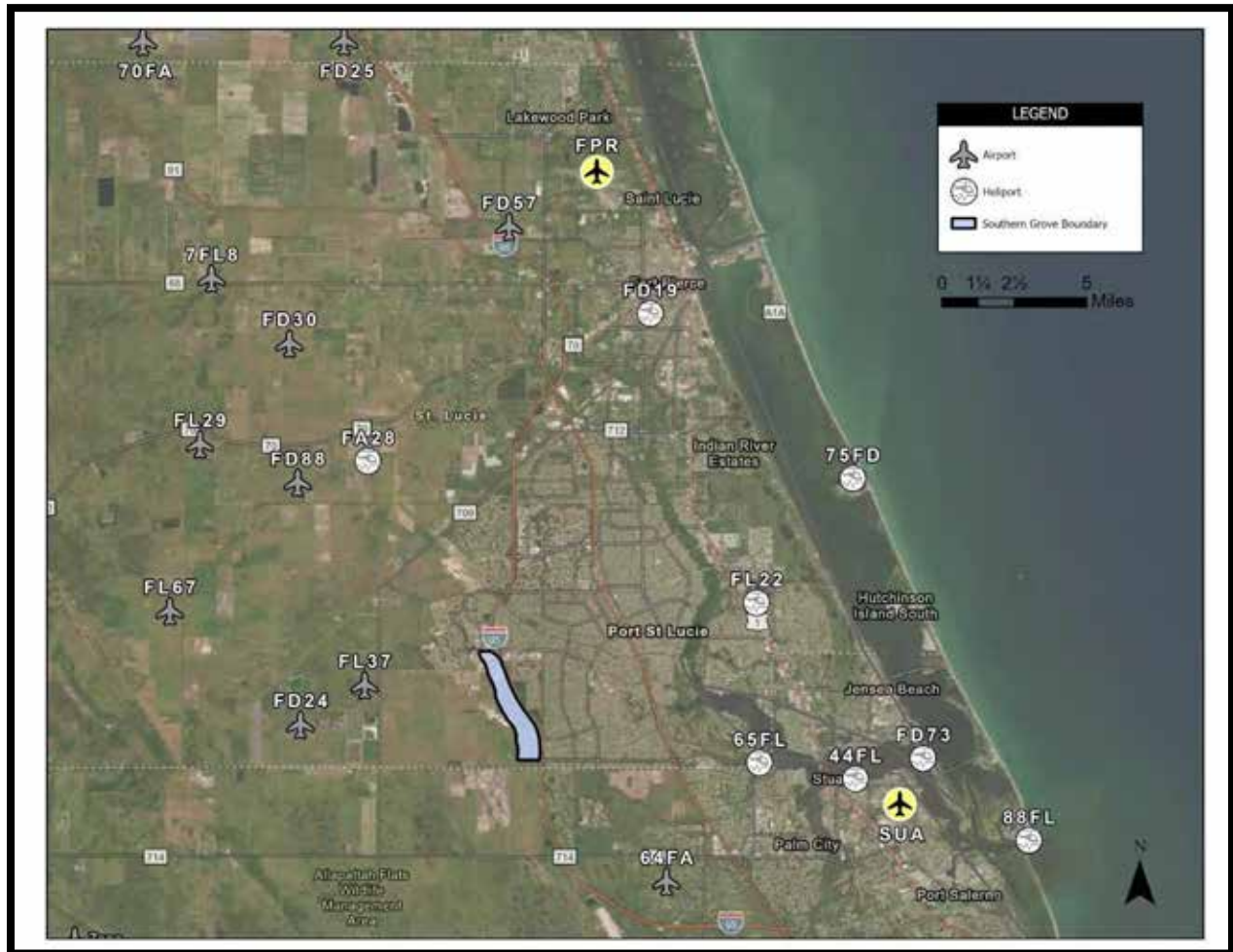

Notes: Facility callout acronyms illustrated above are FAA identification codes.

Source: FAA Sectional / Kimley-Horn.

For purposes of this study, it is assumed that the proposed future vertiport sites as determined in previous chapters of this study will represent initial AAM operating areas within St. Lucie County. Exact locations and designs of these facilities are to be further evaluated once operators are identified and the economics of the operations are verified. No existing airports or heliports were located within the areas identified in Chapter 2 of this study.

4.2. Airspace Structure Overview

Airspace is defined in three-dimensional volumes and organized by the FAA. The National Airspace System (NAS) consists of a network of airspace, airports, air navigation systems, and Air Traffic Control (ATC) facilities, and is governed by a set of rules and regulations that allow for the coordination and control of airspace within the U.S. Classified airspace corresponding to the airports presented in [Figure 23](#) was collected. These data were analyzed to ensure the airspace system and procedures can accommodate the anticipated demands of AAM.

4.2.1. Controlled Airspace

Classification and active control help the FAA organize complex airspace. Restrictions on certain portions of airspace may include specific aircraft equipment, visibility minimums, cloud clearance, and/or procedures when operating inside them, such as communication with ATC. These restrictions assist the NAS to operate at maximum levels of safety and efficiency. Controlled airspace (Classes A, B, C, D, and E) refers to airspace where ATC services are provided. Typically, these classifications are associated with different types of airports and are dependent on the frequency of operations and complexities of the local airspace. Special use designates airspace where specific activities occur or where limitations must be imposed, such as military operating areas or routes, which are typically coordinated by ATC.

4.2.2. Uncontrolled Airspace

Within uncontrolled airspace (Class G) ATC has no authority over or responsibility to control. Other airspace refers to the remaining airspace not covered by the aforementioned classifications.

4.3. Airspace Above St. Lucie

The airspace above St. Lucie County is depicted within [Figure 23](#) below. A glider operating area located northwest of FPR is the only special use airspace within the County. Class A airspace generally begins at 18,000 feet above mean sea level (MSL) and extends up to and including 60,000 feet MSL (flight level 600). AAM operations are not anticipated to operate at this high altitude and therefore will not utilize Class A airspace.

Class D airspace surrounds FPR to the north and Witham Field (SUA) to the south during specified hours. Class D airspace starts at the ground surface and extends upward to 2,500 feet above ground level (AGL). It is required that aircraft establish communication with ATC prior to entering Class D airspace. Class D airspace surrounding each airport is only active when the ATCT is operational. For exact ATCT service hours, refer to the FAA's "Chart Supplement" for each airport.

Class E airspace extends beyond the lateral extent of Class D that surrounds FPR and SUA, and overlays the airports when not operating as Class D airspace. Class E makes up the majority of airspace above St. Lucie County. Class E is controlled airspace by ATC surrounding FPR and SUA, which begins at 700 feet AGL and extends up to 17,999 feet MSL surrounding each airport within the local region, with FPR's Class E merging to the north with other airport's Class E airspaces. Outside the Class E lateral bounds for each airport, Class E begins at 1,200 AGL, as opposed to 700 feet AGL near those airports.

Class G airspace makes up all other local airspace underneath Class E airspace, inclusive of airspace immediately above FPR, up to 699 feet AGL, when Class D is not active. Class G is uncontrolled airspace and operates under VFR.

Figure 23 – Airspace Classifications and Airways Above St. Lucie

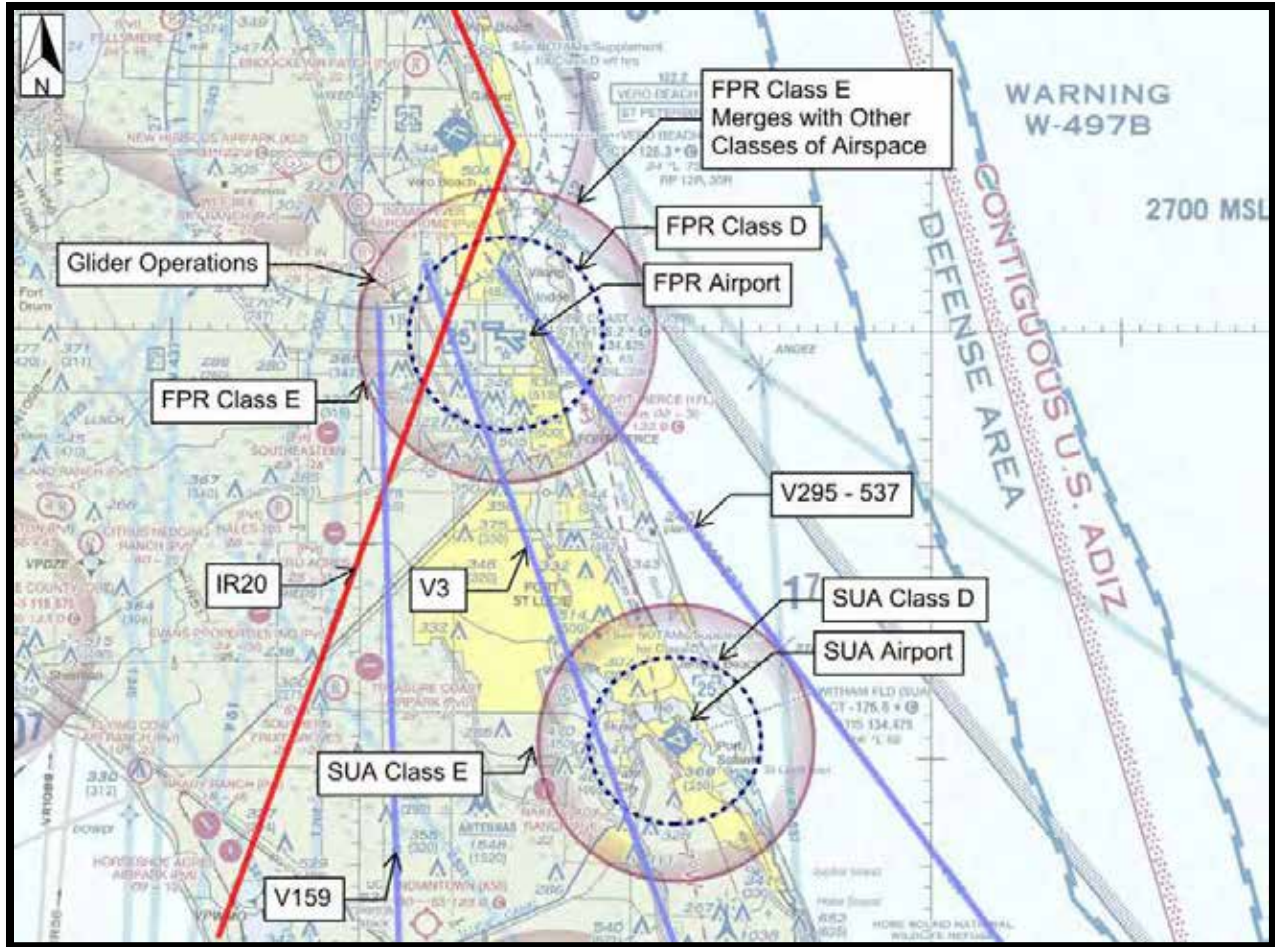

Note: This exhibit is for illustrative purposes and not to be used for air navigation; Victor Airways (V); Treasure Coast International Airport (FPR); Witham Field (SUA); Instrument Military Training Route (IR).

Source: FAA, Sectional Aeronautical Chart, 2024; Kimley-Horn, 2024.

4.3.1. Existing Airways and Routing Above St. Lucie

In addition to airspace classifications around the study area, Figure 23 above also identifies common routes and airways used by aircraft navigating the NAS, such as victor airways. Victor airways are commonly contained within Class E airspace and are used by pilots to navigate between Very High Frequency Omnidirectional Range Stations (VORs), which is a NAVAID used by pilots. These routes are used by a variety of aircraft types and speeds for both VFR and IFR, three of which are near the study area: V3, V159, V159, V537.

A published military training route closest to St. Lucie County, which traverses FPR airspace, was identified. This route, named IR20, is used by military aircraft operating under instrument flight rules regardless of weather conditions traveling at high speeds and low altitudes, typically below 10,000 feet MSL. The route has a width of 8 nautical miles and is commonly contained within Class E airspace.

AAM operations should not impede or interfere with these published routes identified above. Therefore, any operational corridors between vertiports should be sited in a way that does not overlap these routes for extended periods, and minimize intersections to the extent possible.

4.4. AAM Corridors

Any proposed AAM operational areas within this feasibility study must integrate into existing airspace without impeding on aircraft operations. As defined within the sections above, there are multiple airways used by aircraft to navigate in and around the St. Lucie airspace, and the airspace is prominently influenced by FPR to the north and SUA to the south. Additionally, the AAM corridor should factor in noise impacts to the local community, even though AAM operations are anticipated to be much quieter than traditional small aircraft.

A corridor is defined within this study as a volume of three-dimensional airspace that would be used to route AAM operations between vertiports. It was determined that two distinct corridor routes were needed to accommodate potential operations, connecting the three recommended initial vertiport locations: FPR, Southern Grove, and Port St. Lucie West. One would connect directly between FPR and Southern Grove vertiport locations, and another would connect all the three vertiport locations. Each corridor is planned to be 0.5 nautical miles wide due to the anticipated size and speed of aircraft; each corridor is planned to extend from the ground to 2,500 feet AGL which allows for bi-directional vertical separation between aircraft, which is assumed to require 1,000 feet of vertical separation. Northbound operations would be traveling at an altitude of around 1,000 feet AGL, with southbound operations operating at 2,000 feet AGL.

Corridors were planned to follow existing roadways to protect against additional noise exposure to noise-sensitive community areas such as parks, schools, and residential areas. In addition to aligning with roadways to limit noise impacts, roadways are often utilized by pilots and aircraft when operating by visual navigation.

The conceptual AAM corridors aligning to existing roadways and avoiding existing airspace conflicts is shown within [Figure 24](#) below. AAM corridors are not in conflict with victor airways, nor the military training route. AAM operations are anticipated to be in constant communication with ATC when flying inside Class E and Class D airspace. The proposed AAM corridors are predominantly inside Class E airspace, aside from operating near FPR when Class D is active, or under Class E airspace, which reverts to Class G. ATC may route AAM operations differently than what is shown in [Figure 24](#), when operating within Class D to separate AAM operations and other air traffic as needed.

Figure 24 –Conceptual AAM Corridor(s)

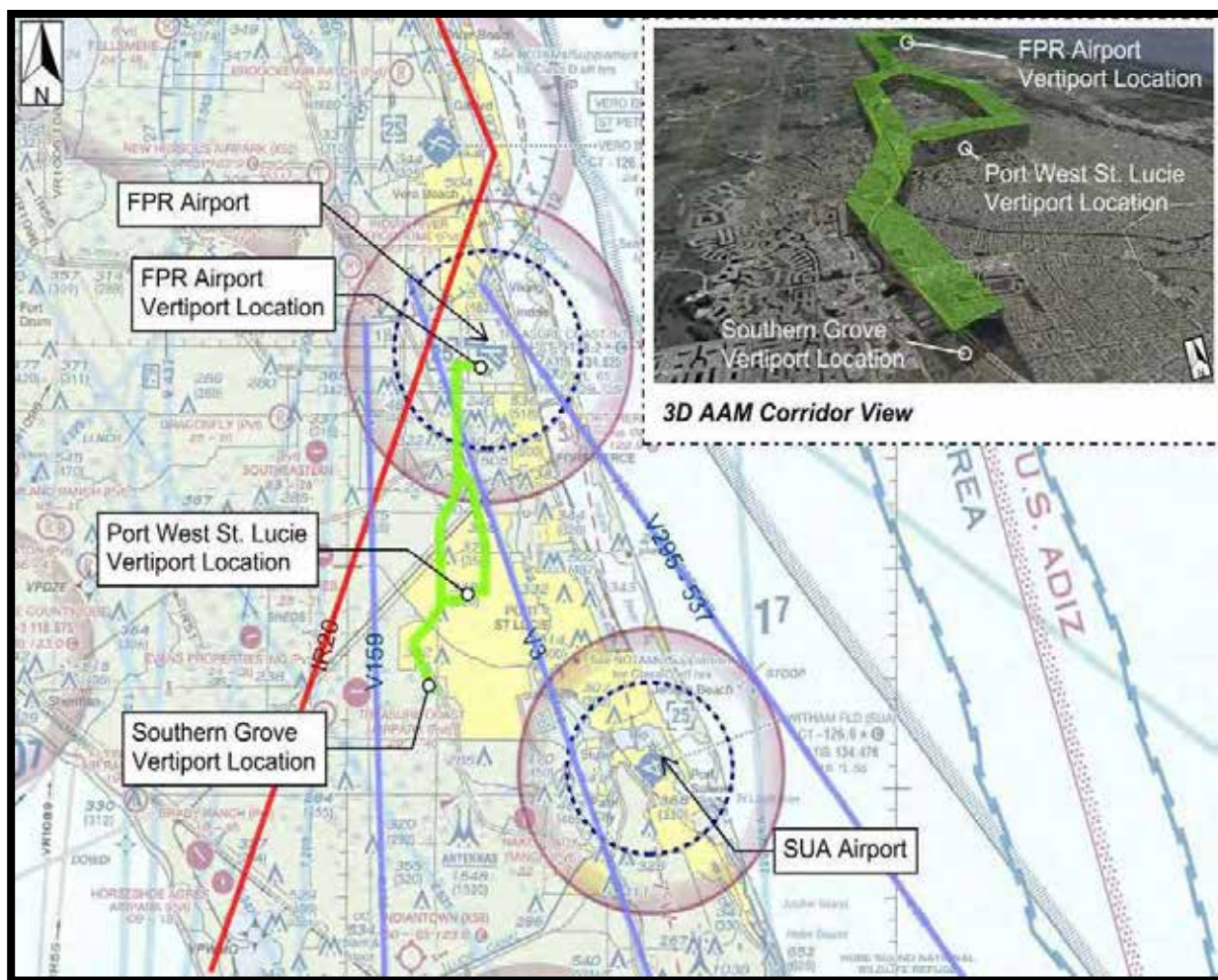

Note: This exhibit is for illustrative purposes and not to be used for air navigation. Furthermore, these corridors represent potential feasible locations, and must be further vetted through design and coordination with the FAA.

Source: FAA, Sectional Aeronautical Chart, 2024; Google Earth Imagery, accessed 2024; Kimley-Horn, 2024.

The corridor distances are relatively short ranging from 6 to 17 nautical miles. AAM travel times will depend on vehicle performance and capabilities. Depending on schedules and volume of traffic, additional corridors or wider corridors may be required to provide adequate separation.

4.5. Final Recommendation – Conclusion

Based on the airspace evaluation, it has been determined that the St. Lucie West Vertiport location is not suitable due to its potential negative impacts on nearby residential areas and short segments with tight maneuvers. Although the surrounding land use of the vertiport itself is compatible, the only feasible AAM corridor that follows St. Lucie West Boulevard would still potentially result in excessive noise impacts on the surrounding community areas such as parks, schools, and residential land uses. On the other hand, the Southern Groves Development Area remains a suitable location due to its proposed large-scale manufacturing, logistics, and retail development and the ability to utilize Interstate 95 as the primary roadway infrastructure for

the AAM corridor to be placed above, thereby minimizing noise exposure on the communities in between FPR and Southern Grove. Considering these factors, the study recommends two vertiport locations in St. Lucie County: FPR and the Southern Grove development area, connected by a conceptual AAM corridor above Interstate 95. **Figure 25** below depicts the final recommendation of the study.

Figure 25 – Final Recommendation

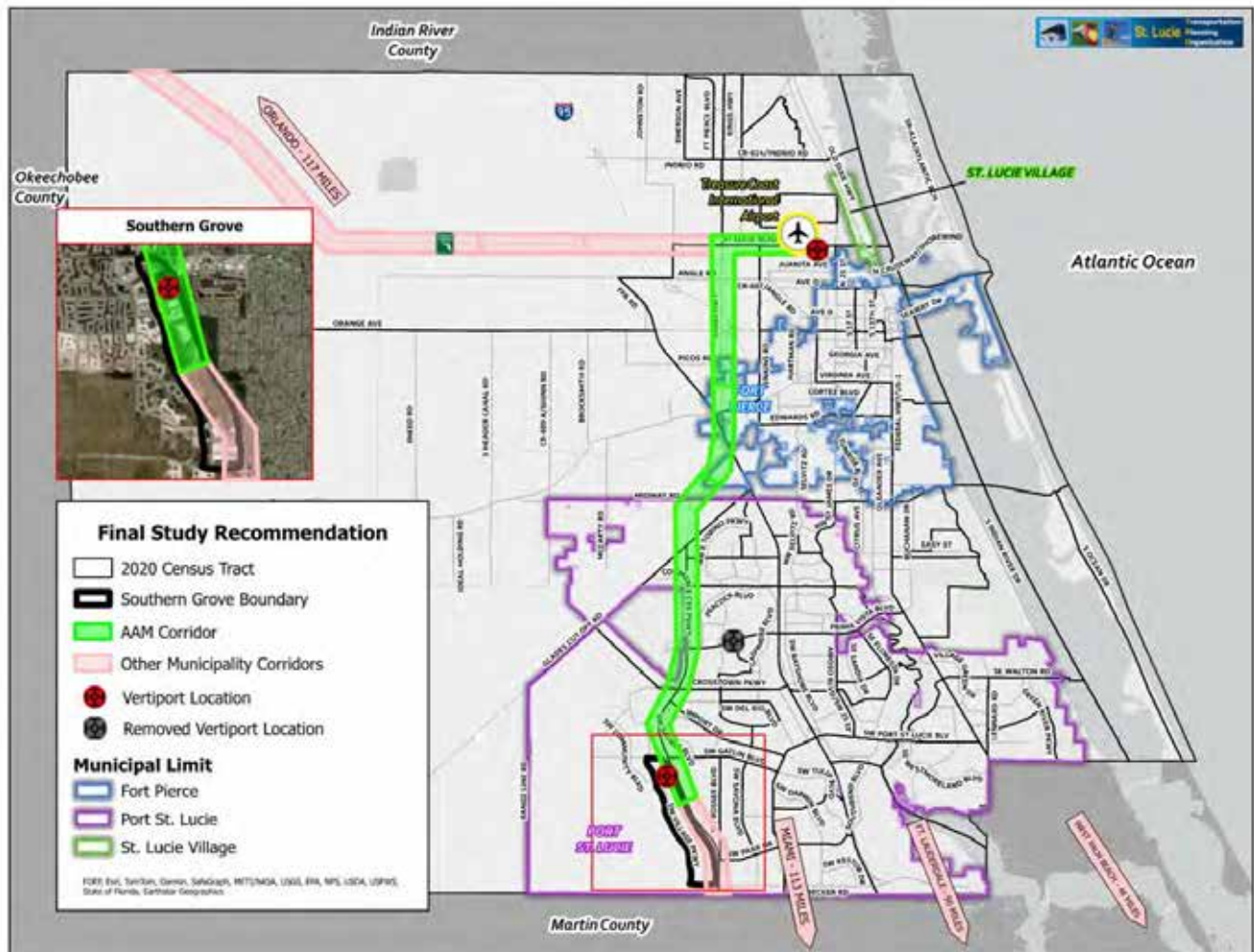

Source: Kimley-Horn, 2024

Lastly, it is important to note that AAM services will heavily rely on existing Aviation infrastructure, such as FPR and connectivity to out of County origins and destinations. St. Lucie is well suited to connect to a larger statewide UAM system, serving as a stopover point or transition point to other locations along the eastern seaboard of Florida and possibly connection to the southwestern portion of the peninsula.

Therefore, off-airport locations for AAM are expected to be developed at a later, mature stage, when higher volumes of AAM traffic is expected. At the time of implementation, the AAM industry would have advanced further and additional variables may need to be evaluated. For these reasons, it is recommended that these recommendations be reevaluated with updated transportation indicators in the future. The two vertiport

locations are recommended and should be further evaluated as part of the TPO's planning endeavors, such as the LRTP.